

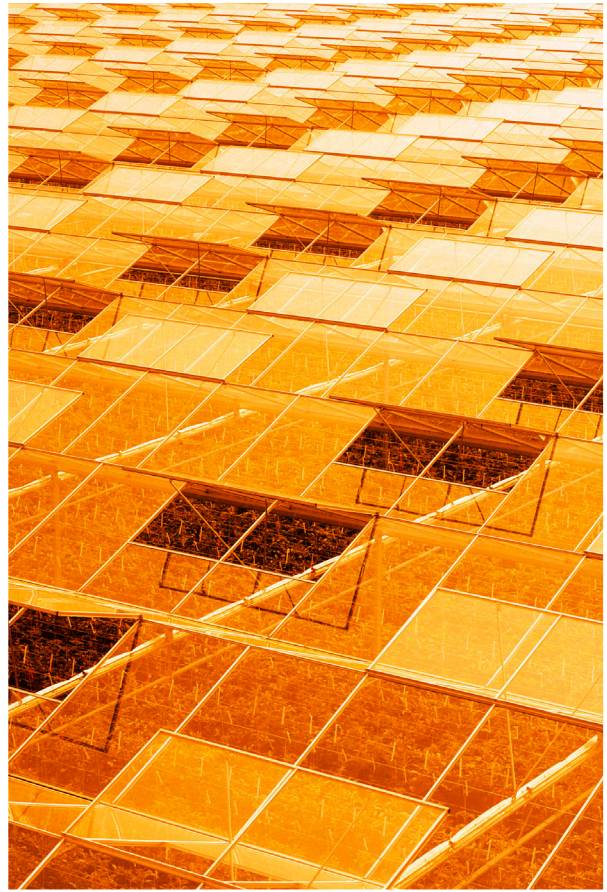

2025
GENERAL CATALOGUE

WORLD LEADING
GREENHOUSE ENGINEERING



About Us

- 05. MCM Engineering
- 06. GM Message
- 07. Engineering & Project Management
- 08. Innovation & Research and Development
- 09. Keyway

Construction

- 12. Construction
- 16. Climate Screens & Driving Systems
- 17. Special Tempered Glasses

Climatization Systems

- 19. Boilers, Condensers and Chimneys
- 21. Burners and CO₂ Systems
- 23. Buffer Tanks
- 25. High Pressure Fogging Systems
- 27. Perfect Climate for Closed Greenhouses
- 31. Air Handling & Dehumidification Units for Greenhouses
- 33. Cannabis
- 35. Ventilation Systems

Irrigation, Fertilization and Automation

- 38. Irrigation and Fertilization Systems
- 40. Greenhouse Automation Systems
- 42. Electrical Systems

Other Systems

- 45. Germination & Cold Rooms
- 46. Reverse Osmosis Systems
- 47. Greenhouse Harvesting, Harvesting and Disinfestation Trucks
- 48. Doors and Hygiene Tourniquets / Stations
- 49. Rain Water Collection Systems
- 50. Plant Growing Gutters
- 51. Plant Growing Environment

Technical Supervising

- 54. Supervising, Service and Commissioning

INDEX



MCM ENGINEERING

MCM Engineering is an engineering group operating in the field of engineering, automation and software. MCM is a group of companies that have completed many industrial, agricultural and commercial projects and produce machinery for air conditioning in its company history of more than 20 years. The group also produces solutions for “Technological greenhouses”, “Modern animal husbandry”, “Systematic automation and software in the fields of energy and air conditioning”.



Cengiz YAYLALI
Chariman of the Board / CEO

MCM Engineering has 3 companies and 4 main brands and each of them operates in a separate line of business. It operates with more than 100 employees in total, 1,500 m2 Istanbul Head Office and 14,000 m2 closed area of the factories in Tekirdağ-Marmara Ereğlisi, 450 m2 Antalya show-room and regional directorate.

Currently, it carries out projects in different regions of the world with its engineering personnel, which conducts projects in more than 50 countries, currently employs 40+ engineers and conducts continuous innovation and R&D studies in its R&D centre. It has a wide infrastructure and uses the ERP (Enterprise Resource Planning) system to monitor and report all business processes.

Our firm, which has completed mechanical or electro-mechanical contracting of over 20 million m2 greenhouse climatization projects and more than 300 projects of commercial-industrial area, reaches to the distributors and end users in different regions of the world.

MCM Engineering engineers and technical staff provide assembly, commissioning and service to different locations around the world from Canada to South Korea, from Russia to South Africa. The system continuously monitors and controls the service and periodical maintenance, throughout its lifetime, with its own service team or other authorized services around the world.





Müslim SEVENCAN
Member of the Board / General Manager

With our strong foundations laid in 2002, we continue to take part in many industrial, agricultural and commercial projects in 50 different geographies of the world, with a solid-mutli brand strategy within our group, focusing on process and software engineering in many different sectors and producing innovative solutions and systems in greenhouse climatizations.

As we continue to prepare a sustainable future, we attach great importance to the compatibility of our employees, our corporate culture and the technologies we use. We have a human structure that values dynamism, continuous development and innovation. We are convinced that we must promote responsible, sustainable and inclusive business practices and act with integrity. We are constantly holding workshops in order to develop the innovation culture and to feed our innovative spirit. Innovation has always been and will always be a driving force at Timfog.

values.

Engineering Excellence

We are engineers, we are proud of our engineering heritage and we strive to be the best in engineering solutions. We do not engineer correctly, we do engineering correct. We always approach to every project holistically and ensure the solution we engineer fits the bill. Our value of engineering excellence keeps us focused on enhancing lives of every customer we serve.

Clear & Open Communication

We believe in the power of clear and open communication. We like to be as clear and to the point as we can and value directness above anything else.

Integrity

We work with integrity and strive to maintain and build on our standards, proving our reputation for reliability. We say what we do and we do what we say. Our word means more than any cost we need to bear. We value universal business ethics and live accordingly to fulfill them.

Customer Focus

We act with a team spirit, aiming to produce solid solutions for our customers. Customer focus mindset enables us to deliver on time, on cost and on quality. We act for project success. We always take our customer's project as our project. We listen, we care and we own. We are genuine.

Teamwork

We believe in teamwork and work with passion. Because we communicate with each department before we go on the field and prefer to lead the match together. We love what we do, and always work with passion, from a distance and up close.

ENGINEERING & PROJECT MANAGEMENT

MCM Engineering mainly serves overseas projects with its approximately 40% of employees who are engineers. By preparing all of its projects in 3D, it prevents mistakes even in the smallest details. The wide project team keeps working on the project together with our customers and field engineers after the contract signed. Almost perfect production-supply-assembly process starts at the planning stage.

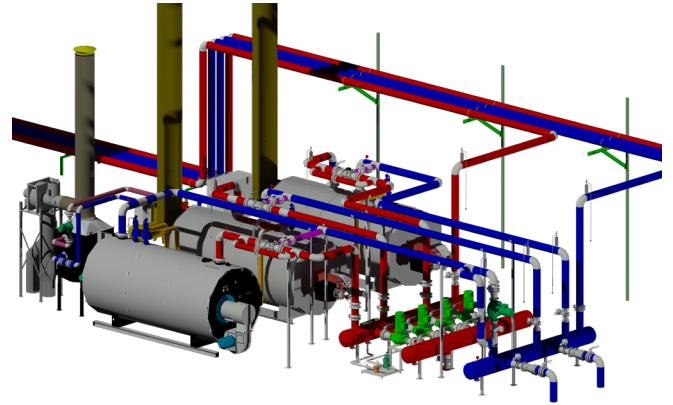

Our engineer supervisors appointed for each project continuously report to our customers during their process on the field. Their periodical availability during the application prevents many misapplications so that construction sites can continue without serious pauses and delays.



The field engineers provide service to our customers with such a process management including the project tracking system which covers the whole project and includes dozens of sub-processes, and ensures that every development can be monitored immediately. In fact, project and site management - which is completely a matter of coordination and coordination - can be carried out easily and comprehensibly with the special Project software being used. Project and field engineers, who can handle hundreds of details at a time, are able to provide perfect reporting and feedback.



INNOVATION – RESEARCH & DEVELOPMENT

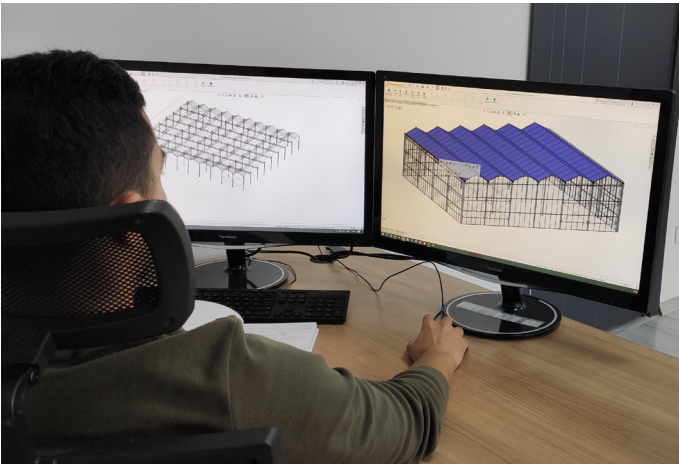

With the simulations it runs, MCM does not only experimentally analyse the air quality of the greenhouses, but also works on very specific methods for the re-use of the chemical fluids such as solvents.

The R&D team runs all the design processes with a standard methodology and conducts long experiments and field tests before releasing the product for production.

MCM Engineering, as one of the leading companies investing in innovation and R&D at its sector, carries out its projects systematically. With the accredited test center located in the factory, we are able to measure the effect and performance of many thermodynamic components on the units such as humidity, temperature and flow rate.

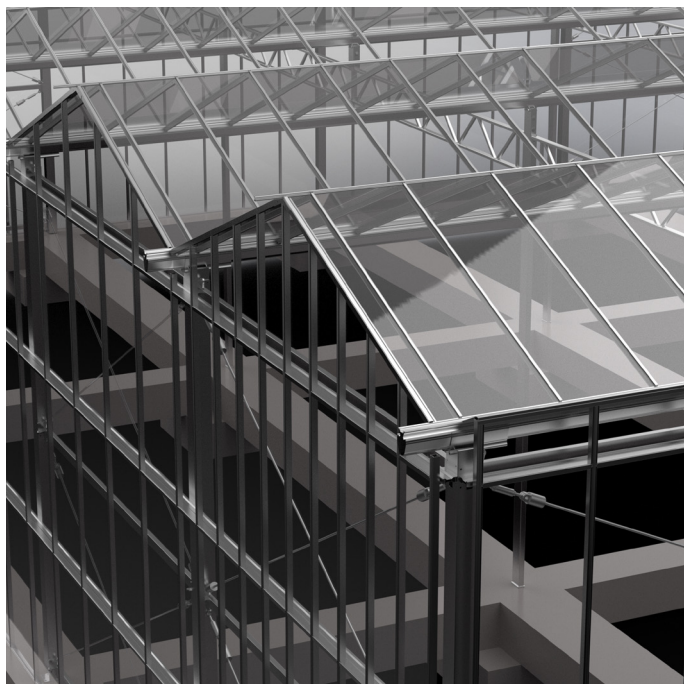
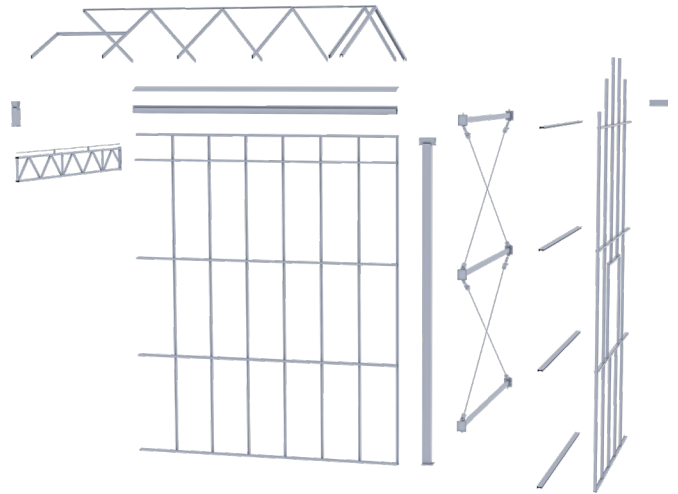

Our engineers, who have been working on moisture control in medical Cannabis greenhouses for a long time, have recently succeeded in commercializing the intelligent ve Greenhouse Air Handling Units and Intelligent Humidity Controllers operating with electricity and / or natural gas/LNG.

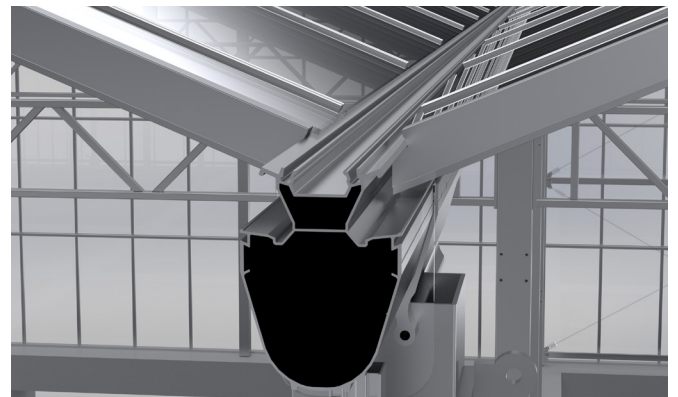

Although glass greenhouse business is an extremely efficient investment, there are very few Turkish companies involved. And generally the planned projects do not include high-tech equipment. The most important reason for this, all of the companies are construction manufacturers but they do not produce indoor equipment. When we say "Why Keyway?" MCM Engineering, a major and serious "Air Conditioning Systems and Electrical Power Panels" manufacturer group, is able to compete with its European competitors as a Turkish engineering company with high quality standards by covering its shortcomings at construction-curtain-automation-irrigation areas with global, strong brands. While competing, Keyway is able to produce flexible and fast solutions due to its strong engineering infrastructure and it can highly be successful in its application thanks to its electro-mechanical infrastructure.

Before making any investment cost analyses, the issue that everyone agrees on is that whether it's a winter season or summer season growing project, glass greenhouses always offer more advantages to the growers rather than the plastic ones.

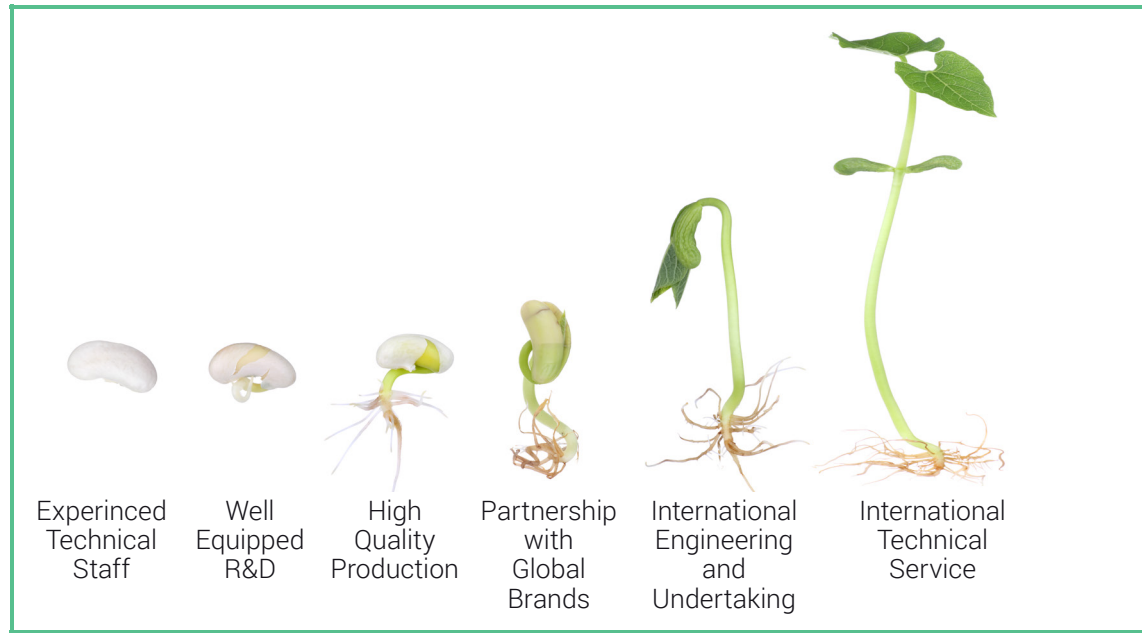

Especially in the dark months such as November, December, January, February and March, when the sunlight required for photosynthesis process in production, thanks to the transmittance of more than 90%, the glass greenhouse offers more sunlight than the plastic greenhouses having a light transmission of 60% - 70%; and gives up to 25% more products in production than plastic greenhouse. This advantage allows the fruit to be sold at higher prices in the winter months when it is difficult to find it and lets the grower make more profit. Under these circumstances, the grower can make +25% profit. Glass greenhouses provide fuel savings from 20% up to 50% in energy consumption compared to plastic greenhouses. In the greenhouses where summer production is carried out, the advantages it offers in the winter months with minimum cold and daylight are of great importance for every grower.





Glass Greenhouse	Plastic Greenhouse
Construction life is more than 40 years	Construction life is estimated as 18 years.
Coating material glass is life-time	Coating material needs to be renewed every 3 years
Tempered glass on the roof not affected by hose or hail	Plastic greenhouses get affected by hose and hail
Less energy consumption costs	More energy consumption costs
Harvest minimum 10% more	
Higher fruit quality with longer shelf life	
Thermal curtain life is longer, with more functions	

In these days since the world's vegetable and fruit production is gaining much importance, due to the improper agricultural practices, the soil becomes increasingly barren and water loss brings inefficiency and the need for modern, high-yield greenhouses is increasing day by day.

Keyway is a Turkish company that aims to produce exclusively and highly efficient, technological greenhouses and will prove itself as a global brand.

Keyway is a company that brings special solutions for flower and medical cannabis greenhouses besides tomato greenhouses and supports the investors with return on investment in greenhouse investments directly affected by factors such as climate, product and greenhouse area.

Not only during the handover of the project, but keeps on supporting the grower especially during the growing time, Keyway offers a special complete greenhouse software which can monitor and track the harvesting, product quality, price, efficiency, labor and other costs.



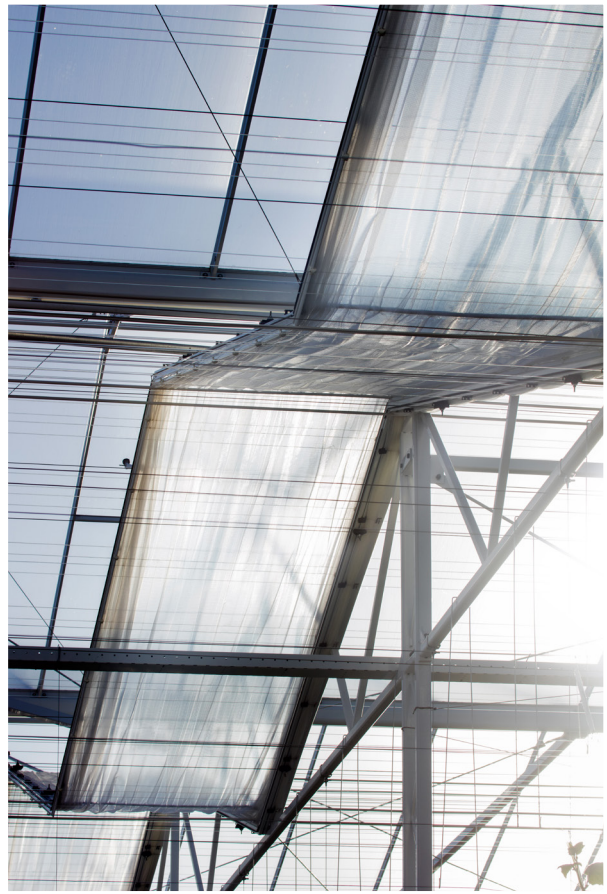

CONSTRUCTION

The “New Glass Greenhouse Construction System” that Keyway has been working on for the past 3 years and implementing under the slogan “Creating Ultimate Greenhouses” has many advantages over its competitors.

1. Ease of Installation: The fasteners currently used in greenhouse structures are made with profiles, bolted together, or joined by methods such as welding. These methods cause considerable difficulty and loss of time in assembly. Drilling and screwing in bolted structures are the basic assembly principles, resulting in a loss of time, reflected in the labor cost.

With its newly developed glass greenhouse design, Keyway offers up to 15% easier assembly than its competitors. In exchange, the aluminum and glass assembly details have been made very simple and much safer with the new design.

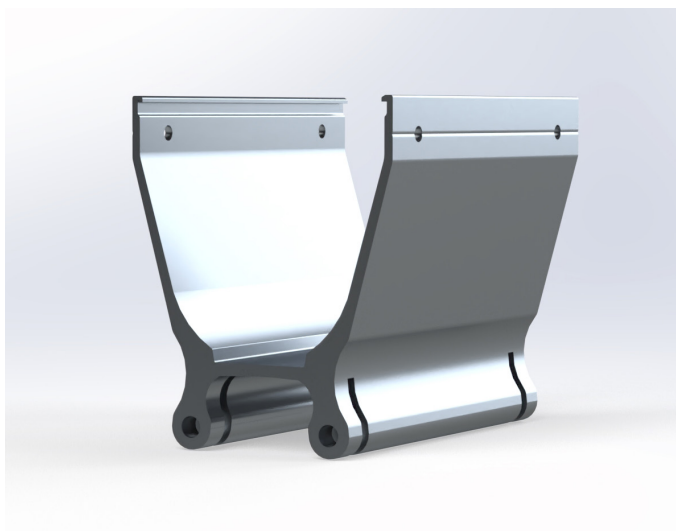

Thanks to the snap-action claw system in the grooved joints, the load on the screws has been reduced by 90%.

3. Very low joint losses (air and water tightness): With the newly developed construction system, the sealing losses (joints) are minimized above all. Impermeability, which is a critical factor in all glass greenhouses, is crucial for the homogeneous air conditioning of the greenhouse interior.

Thanks to the newly developed “Hidden Gutter System” (patented), air ingress into the closed volume of the greenhouse is reduced to a very low level. It also completely eliminates sweat problems on the glass caused by the difference in temperature between the outside and inside air.

2. Strong static and dynamic structure: Due to possible incorrect connection, alignment problems occur, and the strength of the construction structure decreases. Moreover, the difficulty of assembling these methods of connection will cause trouble to the staff. In addition, in screw constructions, almost all the load is on the screws. To reduce the shear stress, it is necessary to use a large number of screws. Keyway has designed a robust construction structure with extremely high static and dynamic strength, interlocking, and less bolted and welded connection equipment in its new construction design.



In the event of sweating, the hidden gutter system keeps water and air out.

4. High Strength on the Lateral Facades: The notched structure of the horizontal profile joint of the sidewall, which is another part of our invention, ensures easy installation. Since the lateral groove is higher than the outer batten, a possible water leakage to the inside is prevented. The fact that the edge groove is shorter than the profile facilitates assembly when installing the glass.

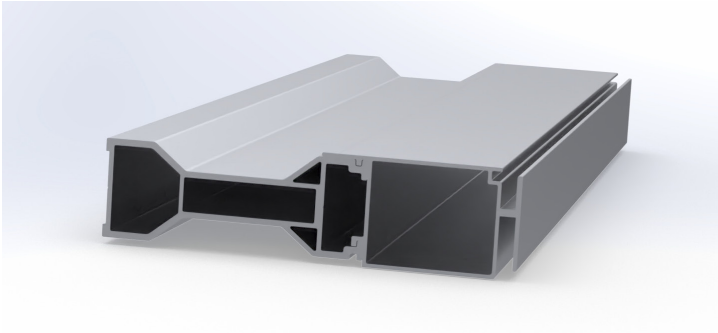

Thanks to the ease of installation and interlocking joints on the side window profiles, these structures offer a more solid and smooth appearance.

6. Window corner joints: The innovation of window corner joints has provided great convenience for faster and hassle-free installation. Furthermore, this detail increased the strength of the glass construction.

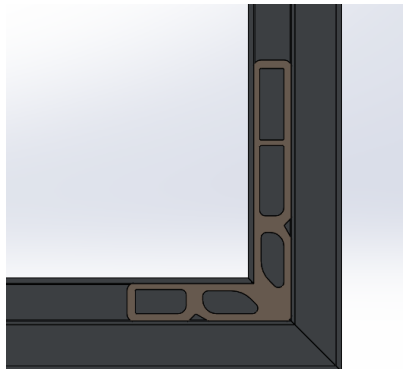

7. A unique design that changes depending on the climate: Keyway's project engineers review the last 25 years of statistics for the region where the greenhouse will be built, considering weather, light, wind, precipitation, and terrain conditions to create a unique design for you. While the main designs of Keyway glass greenhouse construction remain the same, some equipment is selected according to the weather conditions of this region. Therefore, every greenhouse we build is unique to you. With our engineers' 3D project drawings, you have the possibility to keep all possible details about your greenhouse as an archive for years.

5. Low packaging and transportation costs: One of the most significant cost factors in greenhouses is the packaging and transportation costs due to the tens of thousands of parts. With Keyway's new glass greenhouse construction, all drilling and welding operations are completed during production, leaving very little drilling and welding work for field assembly. The high-precision preparation of the connecting parts before assembly provides considerable convenience in transport. The profiles are prepared for bolting by drilling holes on the laser cutting benches of the strut support profiles.

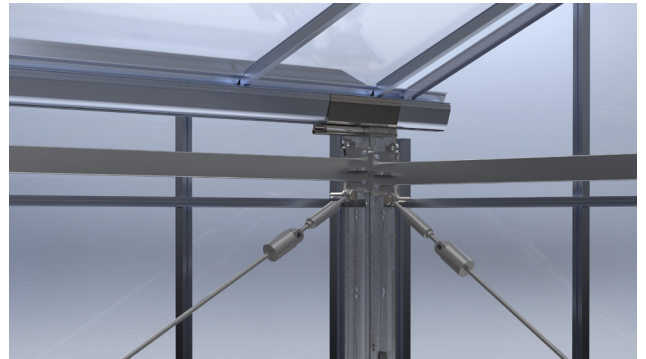

In this way, at least 30% of transport costs can be saved. It eliminates the risks during assembly that can arise from welding operations.

8. Esthetic and ergonomic design: Keyway presents you an esthetic and extremely ergonomic, nature-friendly design with this newly developed system. Glass greenhouse constructions that can function appropriately for up to fifty years, depending on the climate in which they are located, have become a concept that our investors can use with confidence.



CONSTRUCTION

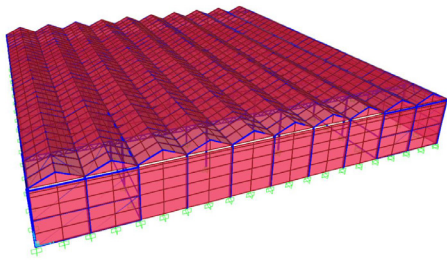

Structural Elements	Von Mises Stress (Mpa)	Aluminum Yield Stress (Mpa)	Safety Factor
Valley	160	240	1,5
Roof Lateral Profiles	32	240	7,5
Roof Vertical Profiles	96	240	2,5
Roof Joint Profile	64	240	3,75
Valley Connection	16	240	15

Detailed Computational Static Analysis

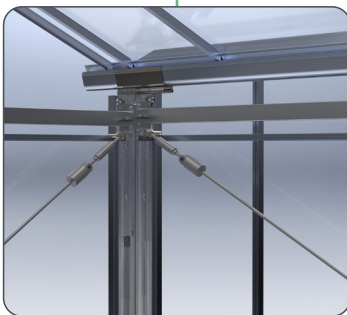
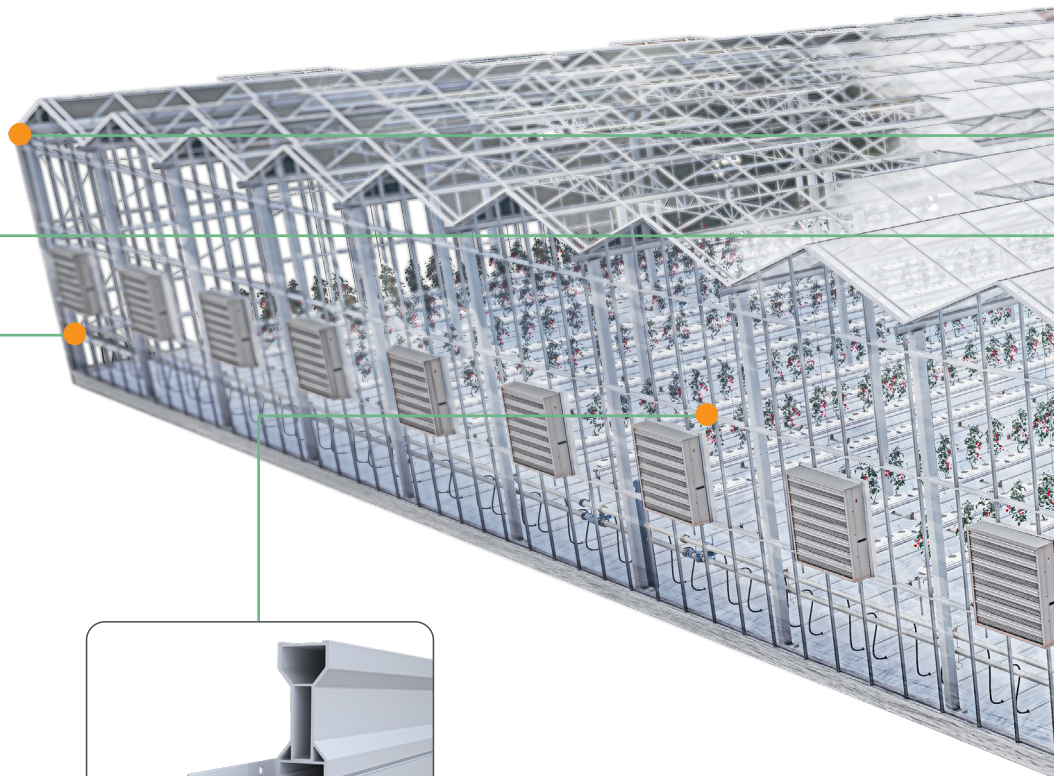
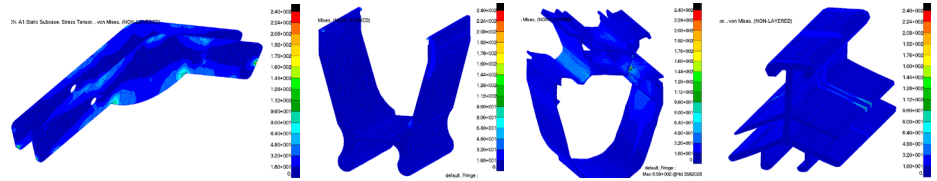

Low Packaging Cost with Unique Design

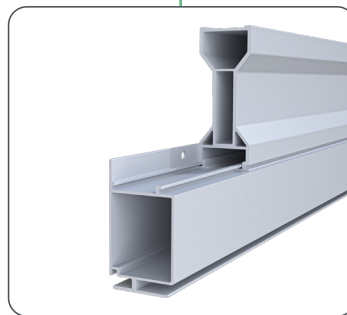

Patented Hidden Gutter System



**Robust Structure
and Ergonomic
Design**

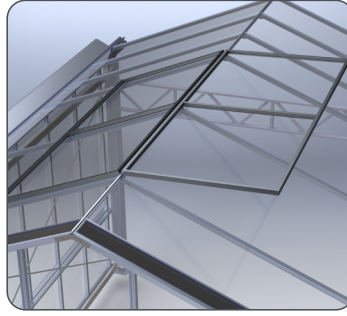

**Hassle-free
Installation**



**The Snap-Action
Claw System**

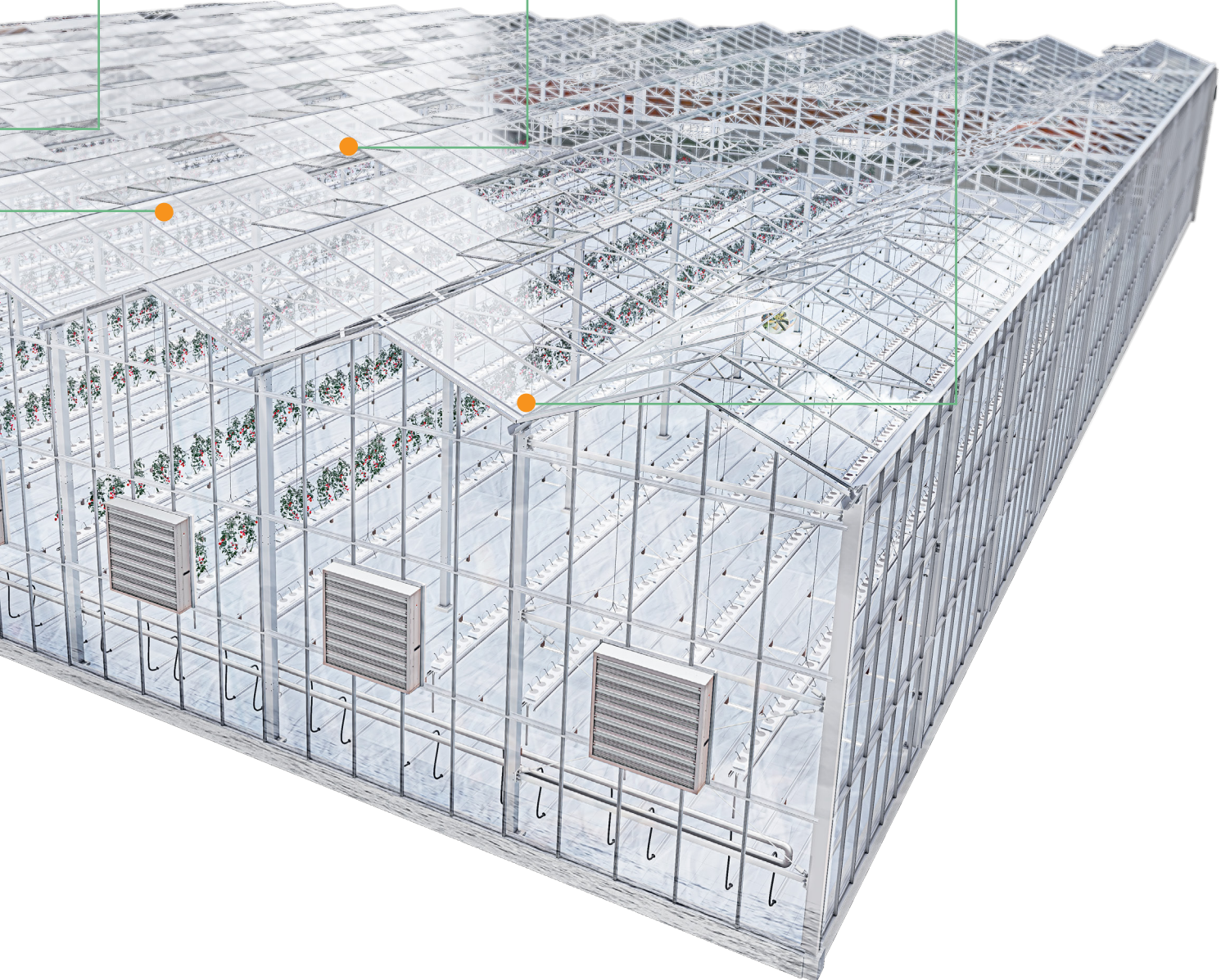

CLIMATE SCREENS AND DRIVING SYSTEMS



Heat curtains for greenhouses have always been a critical issue for greenhouse investors. The arrival of sunlight at the right scale, time, and temperature are the most critical issues in crop production. As a result, greenhouse curtains are an issue that should be carefully evaluated based on the greenhouse investment, the product to be grown, and the greenhouse's location. Greenhouse curtains are grouped under the following main headings.

Black Out Screens: Blackout screens are indispensable for inducing flowering in short-day plants in periods when this does not happen naturally. Such screens prevent daylight from entering the greenhouse.

This artificially shortens the length of the day and allows products such as chrysanthemums, gerberas, kalanchoas and medicinal crops to be produced all year round.

Light Restriction Screens: In order to prevent supplemental lighting from being emitted into the surrounding area, it is vital to use a blackout screen that reduces light pollution as much as possible. The screen must also be able to withstand high temperature and humidity levels in the greenhouse. Light Restriction Screens provide a high degree of light exclusion but, at the same time, still allow sufficient heat through. In addition to being fire-retardant, the screen also has excellent moisture-regulating properties thanks to the special weave of its innovative fabric. The white reflective material on both the inside and outside of the screen enables you to control the temperature in the greenhouse and reflects light back into the greenhouse.

Sun Shading Screens: With Sun Shading Screen, your crop will be protected from direct sunlight during the day, and you can achieve maximum energy savings at night. The Sun shading screens are particularly useful for greenhouse crops that require milder conditions and that involve the use of ventilation or cooling systems, but are also suitable for tropical conditions. Using the Sun Shading Screen, growers can achieve energy savings of up to 68 percent. The open version of the SSS ensures maximum cooling in tropical climates.

Energy Saving Screens: Energy saving screen has developed the Ridder Energy Saving Screen for crops that require intensive heating. This highly transparent energy-conserving climate screen prevents heat loss, allows valuable daylight in, and ensures the best possible climate for growing thanks to its excellent moisture-regulating properties. The Energy Saving Screen provides energy savings of up to 47% and guarantees a more consistent growing climate through effective temperature distribution. The clear, transparent fabric minimizes light loss.

Light Diffusion Screens: When daylight is distributed better and can penetrate further into the greenhouse, this benefits the quality and consistency of the crop. In addition, diffuse and indirect light reduces the risk of leaf scorching and plant stress. This maximizes crop health, resulting in higher yields. Light Diffusion Screens literally give your plants a place in the sun. Its knitted structure, in combination with the light-diffusion strips, ensures an even distribution of light. The Light Diffusion climate screens have a closed structure, which results in energy savings and less condensation because the crop cools down more gradually in the evening.



Drive Systems

Accurate control over the climate in your greenhouse means a better quality crop, increased production and lower energy consumption, enhancing the overall viability of your operation. The use of air vents, sidewall ventilation and screen systems is therefore a crucial part of every grower's production strategy. These greenhouse features enable you to achieve a more productive greenhouse climate, helping your crops and your business to flourish.

Keyway projects team understands that good drive systems are important for growers. We work with greenhouse builders and installers, using our innovative technology and expertise to develop the best drive solutions and make growers' lives easier. These solutions not only create the perfect greenhouse climate, also provide protection and peace of mind, because they give growers full control over their greenhouse and climate, even in the most extreme conditions. In view of the advance of greenhouse growing around the globe, we are also responding to the demand for drive systems that are optimized for local conditions and techniques.

SPECIAL TEMPERED GLASSES

Every entrepreneur wants glasses that provide optimal efficiency at the lowest possible cost. Furthermore, light transmission, UV transmission, and insulation value are essential considerations in this decision. The choice of greenhouse roof greatly impacts the extent of diseases due to pests, fungi, and viruses. The standard glass used in safe glass greenhouses has a thickness of 4.0 mm and a light transmission of about 90%. In most cases, safety glass or tempered glass is used. This type of glass is four to seven times stronger than normal glass. Depending on the region where the greenhouse will be placed, it may be more appropriate to use diffused glass (diffused glass). Diffused glass affects the diffusion of natural light in the greenhouse. It "scatters" the direct sunlight and makes it penetrate deeper into the plants

- Long-lasting (50 years)
- High strength.
- The coating material is natural, does not contain chemicals such as UV, IR, such as plastic.
- High resistance to moisture, does not collect water, and does not drip.
- High and natural light transmission means high efficiency, especially in the winter months.
- The quality and luster of the vegetables are high, and the shelf life is long.
- The production efficiency can be increased by up to 15% with the diffusion liquid on the outer surface.
- High energy savings.





CLIMATIZATION SYSTEMS



BOILERS, CONDENSERS AND CHIMNEYS

The hot water boilers used in the Keyway projects are perfectly suitable for greenhouses using CO2 as well as for normal greenhouses, thanks to the special system inside.



Keyway has gained international experience in greenhouse heating systems with more than 250 boilers that the company has put into operation so far.

As a result of R&D studies carried out with manufacturers, the company has developed and commissioned systems that produce very low levels of NOx, especially in boiler plants where CO2 is extracted from the flue gas.

With a much lower flue gas temperature than normal boilers, these boilers offer investors significant fuel savings.



Thanks to the 50 + 50 mm rock wool insulation surrounding the outer wall of the boiler, it is ensured that the hot water in the boiler can be kept for a very long time without cooling. Keyway uses high-quality and very compact hot water boilers thanks to the cooperation with international boiler brands. Thanks to the unique designs for the 2nd and 3rd flame pass in the boiler, the internal temperature of the boiler is maintained at an optimum level. Thanks to their compact structure, these boilers have advanced features that can be used for any greenhouse.



Flue gas economizers/condensers are used to cool flue gasses from natural gas-fired plants. In most installations, economizers are located at the back or top of the boiler. The energy in these installations is used to heat the water. The maximum temperature of the exhaust gasses in the economizer is 210°C.

The water circulating in the installation is heated to a maximum temperature of 95 ° C by using the additional efficiency of the flue gas economizer. The economizer is part of a closed system with a maximum permissible pressure of 3 bar.

Flue gas economizers are usually installed behind gas-fired boilers. All flue gases from the boiler are passed through the economizer, where they are cooled, and the heat from this process heats the water in the closed system. The remaining highly cooled flue gasses are either discharged to the open air or used for CO2 metering or other applications.



BURNER

Burners that burn and heat the water in the hot water boiler using natural gas/LNG or diesel oil are at least as important as boilers. It is vital for the greenhouse plant that the burner is particularly high quality and works smoothly. The biggest problem encountered when using international burner brands is burner service. The inability of the services to be in the greenhouse on time, the delay of commissioning, or the inability to get service in the event of a malfunction are the problems that cause investors to lose their product or lose a significant portion of their efficiency.



With its technicians and engineers in its infrastructure, Timfog provides commissioning, supervision, and servicing services from Istanbul to worldwide through its foreign language-speaking staff. Therefore, the supervision services it offers are much more economical than the Netherlands or similar European countries.

Timfog is a company specialized in the design, manufacture, installation, and maintenance of equipment that provides excellent combustion quality thanks to the collaboration with international brands of burners.

With its CO₂ and CO₂-free burner control systems ranging from 1,000 kW to 15,000 kW, it provides reliable and timely service in greenhouses. In particular, the low NO_x level in the burners and the high combustion efficiency distinguish the Timfog project and technical staff compared to other project companies. All burners used have international certificates and safety criteria.



CO₂ SYSTEMS

CO₂ units are used in greenhouses for central CO₂ dosing. The flue gas emitted from the natural gas-fired boilers and CHP units are transported to the greenhouse area by the CO₂ blower by lowering its temperature. The flue gas is then distributed into the greenhouse using U-PVC pipes through special calculations. A CO₂ control panel is available to control the CO₂ dosing system. If there are multiple fans, this can be controlled centrally from a single control panel.

Şekil: CO₂'nin üretime etkisi. Dış hava yoğunluğu korunurken üretim seviyesi (330 ppm) %100 seviyesindedir.

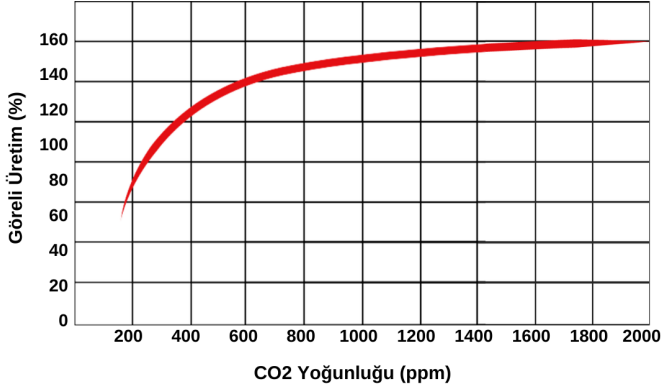

In addition, other control parts such as a CO detector, a CO₂ sensor, or an air damper can be connected to the control panel. The CO₂ control panel can also communicate with the burner control panel. The switch panel has all the control and safety equipment. Furthermore, this panel is supplied in accordance with local safety regulations. The CO₂ detector prevents harmful CO (carbon monoxide) from entering the greenhouse area.

The CO₂ pressure distribution, which must be calculated considering the total surface area, is generally optimized by distribution through the CO₂ blower installed in the boiler room. Therefore, the U-PVC pipes needed will vary in length and diameter. The diameter of the holes in the plastic nylon air ducts used for CO₂ distribution also varies according to these calculations. For a correct calculation, it is important to know the plant type and the required dosage standard (a value usually expressed in cubic meters of gas per hectare). The Timfog project team guarantees the best possible dosing result with the CO₂ pipeline calculation and projects.



BUFFER TANK

Area of the surface in contact with the water on the inner surface is minimized by using NPU's at the external zone instead of tension bars used in the inner part of the tank during manufacture of the classical tank. So, tank life will be extended. The circle used outside the buffer tank increases the durability of the tank and balances its position thanks to the NPU supports. A high level of strength is provided via use of sheet metal at appropriate thickness (from 4mm to 8mm).



The quality of sheet metal used is ST37, the international standard. Special oil sand is used for the bottom of the buffer tanks manufactured, and the tanks produced in line with the layout and design information provided by the Timfog engineers serving greenhouses smoothly for many years.

Oil sand, fills in the gaps between sand grains, and avoids occurrence of foreign particles such as humidity, corrosive acids and also prevents corrosion of the plates under the bottom surface. An average of minimum 20 cm fireproof wool insulation material is used depending on the climate conditions. The air above the water level within the tank must be deoxidized constantly for not leading to oxidation-corrosion. Therefore, a nitrification system at high quality standards is used.

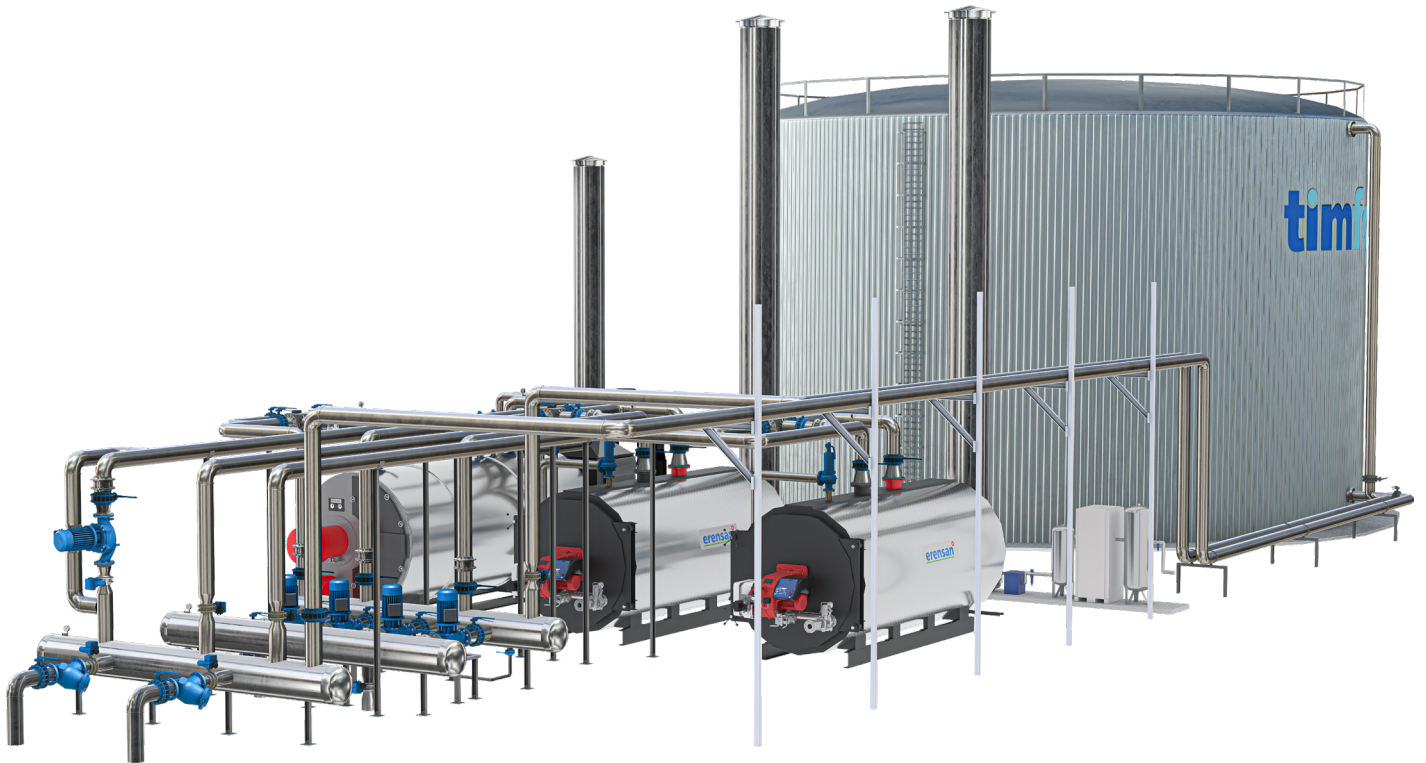

It's also extremely important to check sudden pressure changes within the tank in order to prevent quick expansion and vacuum pressure while filling and discharging water. The deformation and collapse of the tank resulting from the potential pressure changes in the tank might lead to extensive damages and loss.

As one of the limited number of simulated buffer tank manufacturers in the world, Timfog Engineering produces at international quality. All sheet metal and construction designs are made by Timfog engineers. All necessary tests at international level are performed in a computer environment before manufacturing.

All Project details and all assembly details required during installation are shared with the customer. Timfog buffer tanks are manufactured with high hardware components. (Manhole-discharge valves-inner stair-outer stair-filling system-roof ralling.)

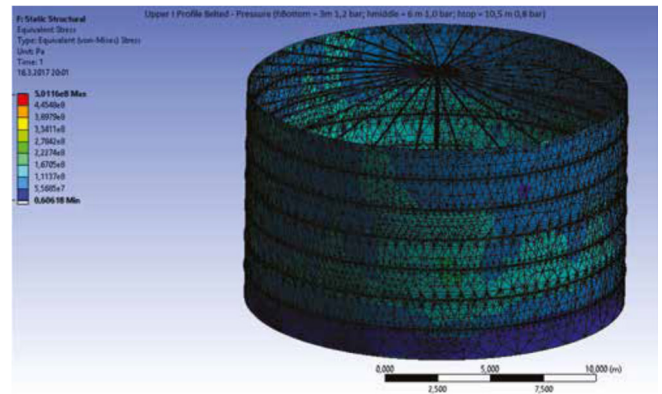

All the tanks produced by the Timfog engineering are simulated by 3D modelling by engineers before production is started. Thanks to this simulation modelling programs, we observe all hydrostatic and hydrodynamic reactions before the tank is manufactured and started to be used. Thus, all technical problems that may occur during tank manufacturing and all the problems that may be dangerous are predetermined. Also, it simplifies the construction process and ensures the establishment of a more efficient physical and operational system.



HIGH PRESSURE FOGGING SYSTEMS

Ideal living environments of the living creatures deteriorate in conditions of extreme hot or cold, excessive or low humidity. Ideal environment for evaporation transpiration and photosynthesis that are very important for growing plants can be created by controlling the humidity in greenhouses. Better quality plants, faster harvest and less insect and less disease problems occur with right humidification systems in greenhouses.

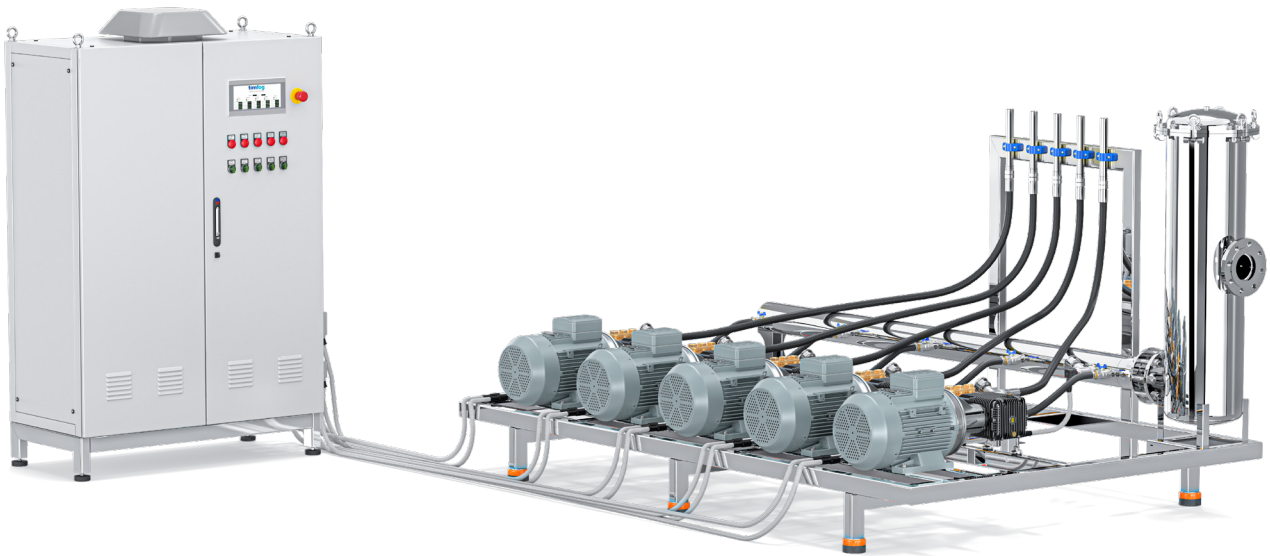

Heat can be dropped and relative humidity increased with Timfog system as a result of evaporation of billions of water droplets sprayed from fogging nozzles by absorbing the heat of the air. The resulting cool and wet weather is used to keep the desired climate conditions in the greenhouse with Timfog circulation fans, ventilation and control systems

Thus the adverse weather conditions for the plants that may grow in the greenhouse are minimized. Wastage rates decrease and productivity increases because of the favorable conditions occurred for work environment and plant growth with decreasing temperature .

Timfog fogging systems are designed to operate at pressures between 70-120 bars. In Timfog fogging networks we use “stainless steel” pipes, fittings and nozzle tips that can withstand pressures of 100 bars and more. All the materials used on the main pipeline and fittings and nozzle bodies, nozzle tips are made of stainless steel. So such a material quality enables Timfog systems to be used for liquid based pesticide spraying inside the greenhouses.

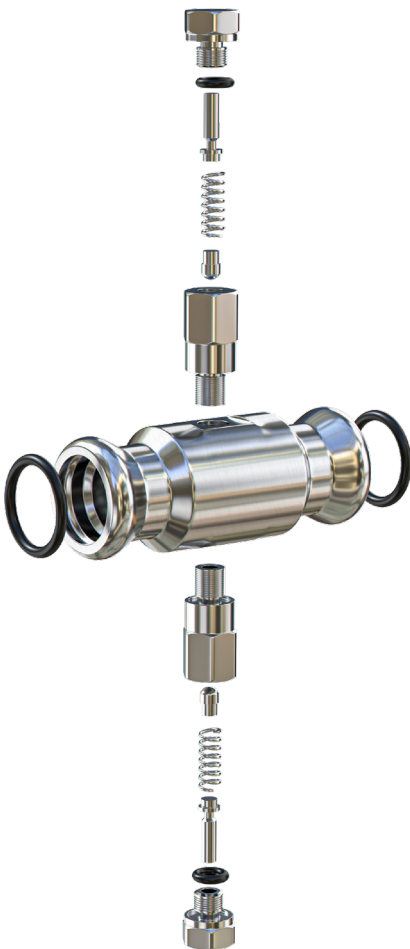

In the greenhouse applications of Timfog systems we use press connection technique. Press fittings are made of “316 Stainless steel” material; The advantage of using press fittings is that it speeds up the installation process and enables us to complete the installation in significantly shorter period. With Timfog systems; it is possible to spray liquid based chemicals into your greenhouse without harming your fogging network.

Timfog engineers developed a special welding system which has electric resistance technique and only used by Timfog systems. In this technique, SS nozzle bodies directly welded to the SS pipes without using any secondary material. The leakage problems at the connection points related to the corrosion and gasket erosion are completely eliminated by this technique. Fast and reliable production is possible. 100% of our production is tested at 150 bar pressure before leaving our premises.

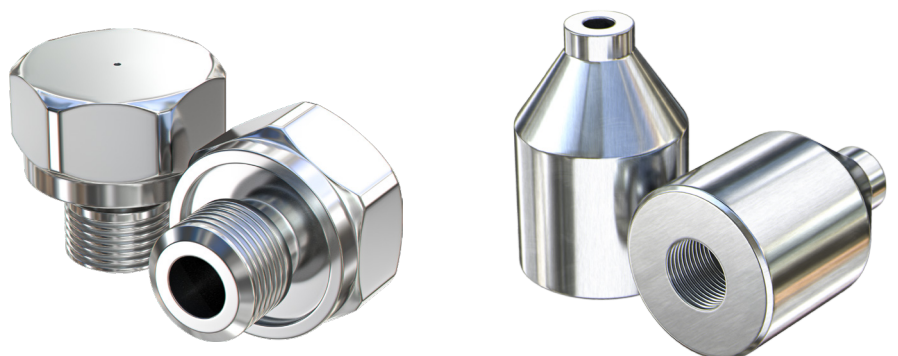

PERFECT CLIMATE FOR CLOSED GREENHOUSES

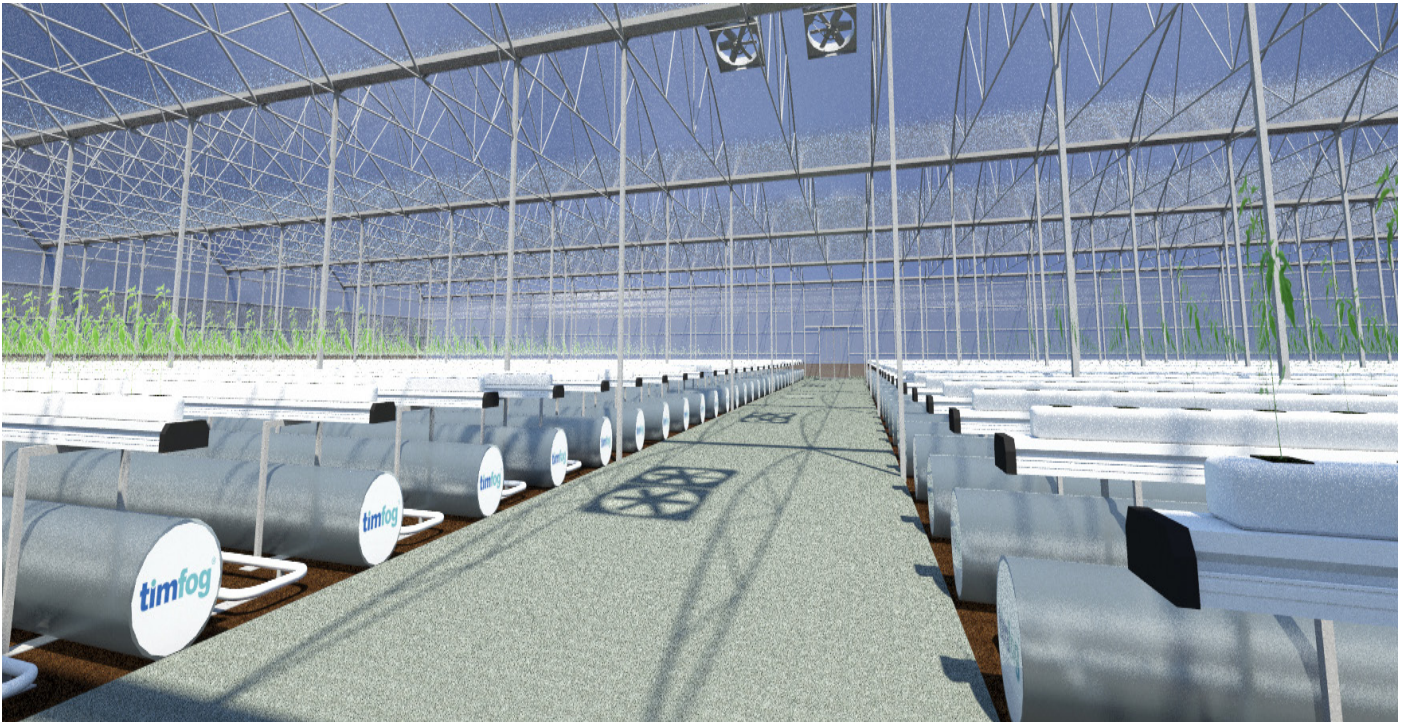

In standard fan or pad implementations, the temperature cannot be fully reduced because of the air, which has been filled up with moisture, not being able to evacuate at the same velocity. The air temperature raises after air passes through the evaporative pad on the way to the insides of the greenhouse and increases up to 8 degrees between the absorption section of the exhaust fans and the pad.

Greenhouse tunnels have a maximum length of 50 meters and diminishing in performance can be seen as the distances get greater. The biggest drawback in standard fog executions is that the air cooled adiabatically cannot be rapidly discharged. Thus the air temperature is constantly kept over a value of the wet bulb temperature. That means to equalize the peripheral temperature and the domestic temperature in greenhouses whose internal temperatures are 8 to 15 degrees more than the outside temperature due to the daylight. However this temperature is not adequate for greenhouses that want to produce in summertime.

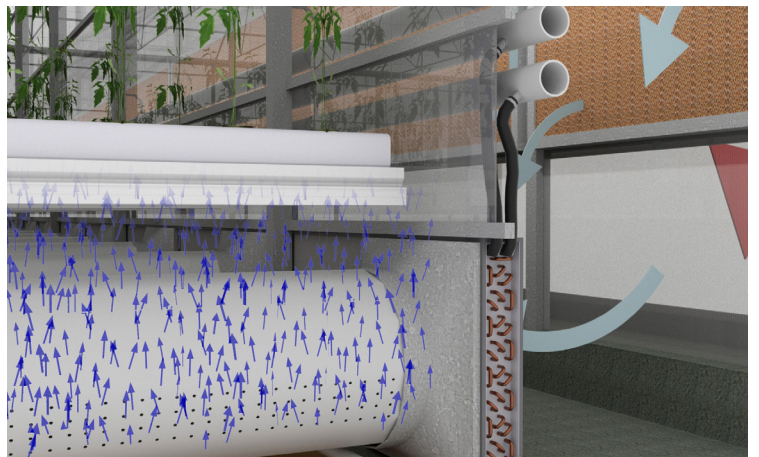
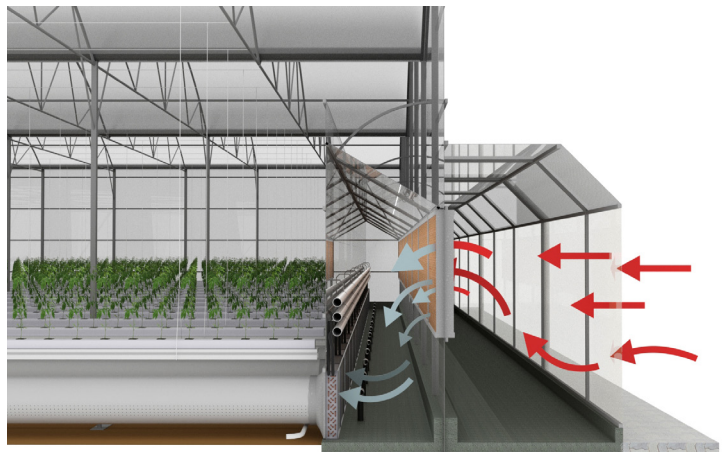

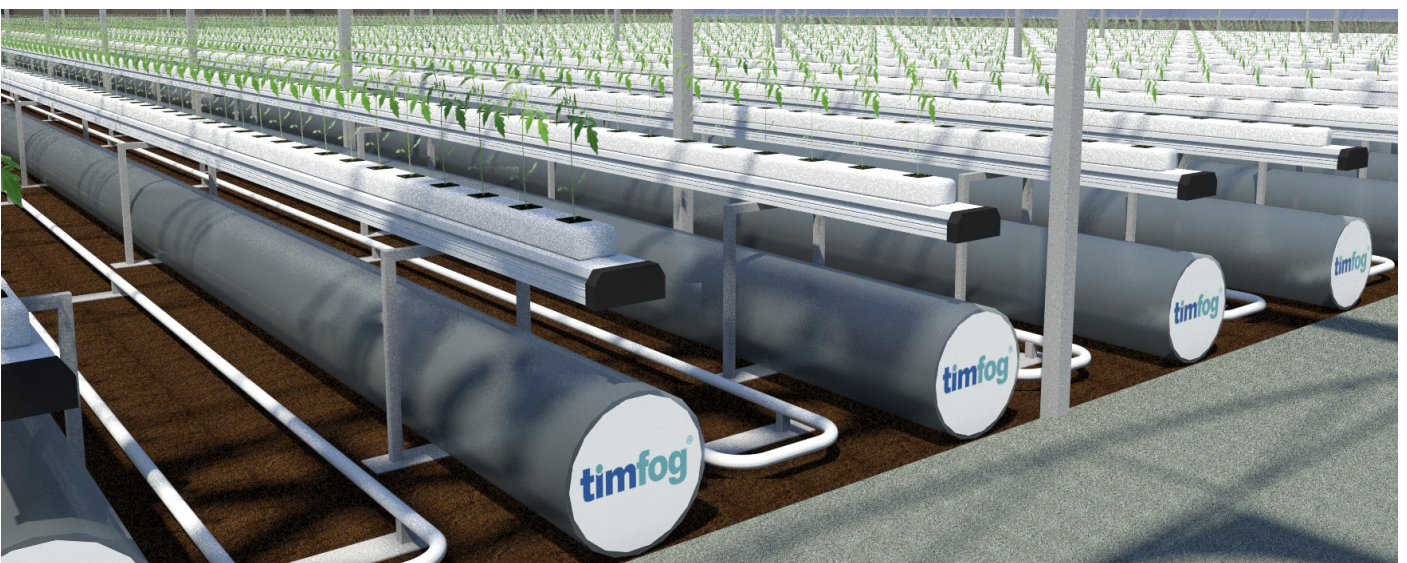
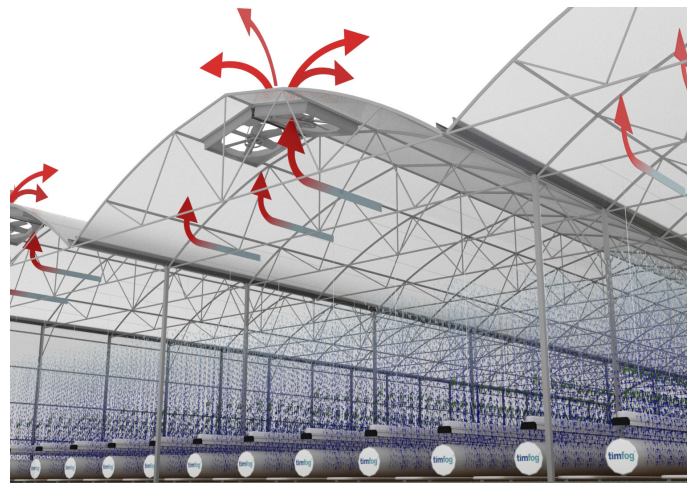
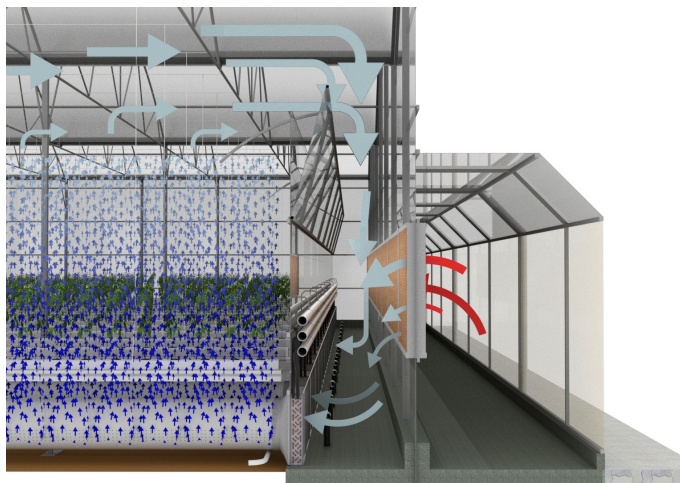

PERFECT CLIMATE FOR CLOSED GREENHOUSES

The most significant plus in winter time production in closed greenhouses is great sunlight. The butterfly roof ventilation systems in conventional greenhouses block sunlight because of their high construction element presence. This handicap isn't present in closed greenhouses. The removal of standard ventilation systems in closed greenhouses decrease the construction expenses to a large extent and contribute to the greenhouse investment expenditure.

The most crucial difference is that insect net is used in the climatization corridor entrance instead of the roof. Thus the amount of entering air is largely improved. As known, in standard greenhouses, the insect net's permeability decreases up to 50% in only one week.

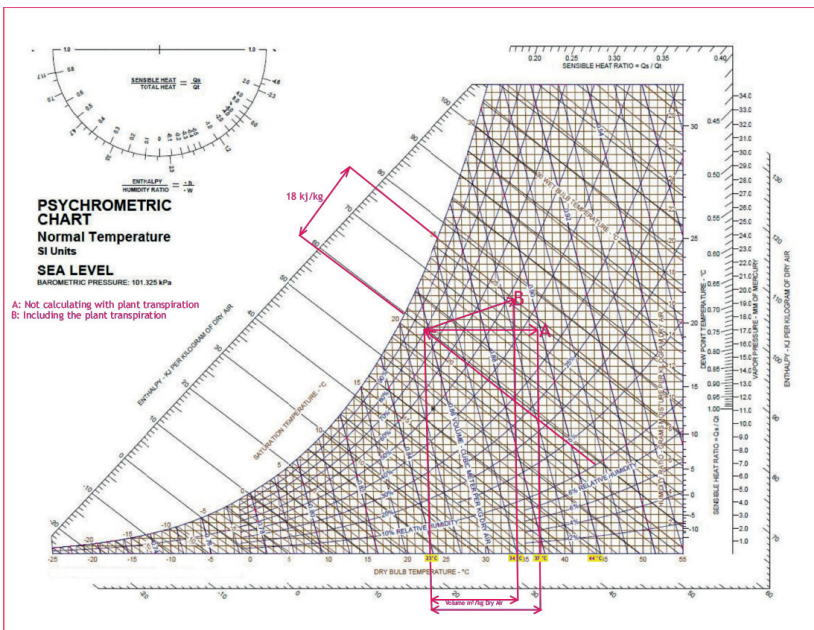

Normal evaporative fan-pad

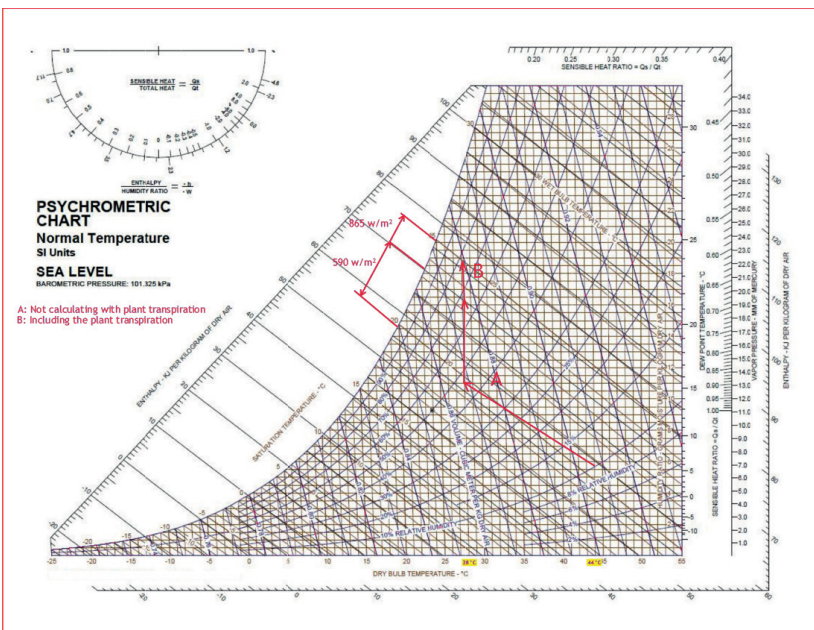

Perfect Climate

After a month or so, this permeability is reduced further up to 20%. Unlike the others, the insect net used in the climatization corridor entrance has more permeability because of forced air circulation. All the circulations and appreciations are made considering the whole year. The system's free-cooling effect is used.



Sometimes inside the greenhouse only the outside air is sent without any cooling or humidification. With the perfect ventilation method, the plant is prepared neither in summer nor in winter, resting tired the next day.

The desired evaporative cooling effect is provided by the static humidity ratios. The internal sectors of the greenhouse is ventilated well in order for the plant to achieve better photosynthesis. The moisture ratios inside the greenhouse remain in a specific balance, the plants inside the greenhouse stay at a reasonable humidity and warmth, not experiencing any extreme moisture drops or upsurges.

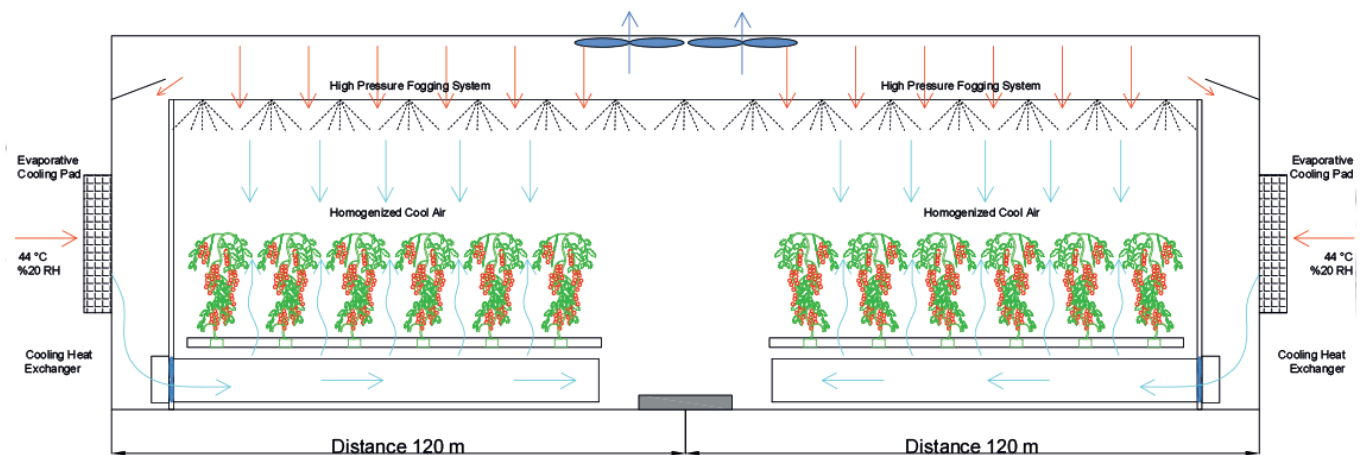
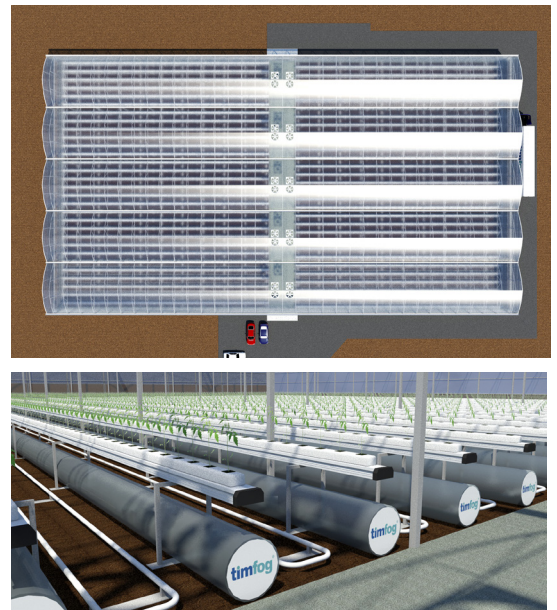

Temperature and humidity comparison tables between normal evaporative fan pad and perfect climate system

The cooled air is distributed evenly across the greenhouse. Special fabric canals which are resistant to intense warmth and frostiness are used for this duty. The air circulation from the bottom to the top is perfectly done eliminating all immense temperature differences.

GAHU

Gahu with compressor and desiccant can be controlled proportionally with the fresh air and the inverter fans used on the blowing air side. It performs the humidity and temperature control in the greenhouse completely automatically. With digital control, the ambient air humidity and temperature are controlled precisely.

It provides the heating of the greenhouse with the hot air it produces during the winter season. It has a low energy consumption, it cleans and filters the air. It purifies a significant part of the bacteria in the greenhouse helps to prevent diseases that will greatly reduce plant yield in enclosed areas such as greenhouses or seedlings. It also helps 90% of disease and sports prevention. It does not contain any chemicals and its dehumidification and heating process is completely organic. With its compact exterior dimensions, it can be easily placed just outside the greenhouse.

The system is based on the principle of absorbing the humid air and heating with the aid of a solid zeolite dehumidifier rotor and a blower burner. Then cooling coils in GAHU decrease the temperature and dehumidify the air for the second time.

Key Features

- Compact unit-easy assembly
- Optional hygiene mode, plus HEPA filters
- Low energy consumption
- Better yield quality and quantity
- VPD based precise digital control and automation
- Full integration to universal greenhouse automation systems
- Capability of being monitored and controlled remotely

Understanding VPD and its impact on plant development and resource utilization is essential for grower to optimize yields and costs.

Timfog's GAHU determines necessary changes with its own automation a special VPD algorithm enabling the healthiest environment and ultimately maximizing plant growth and health.

It provides a more accurate indication of the current evaporation potential since it combines the effects of both temperature and humidity into a single value.



VPD- Based Air Handling Unit with Standalone Automation.

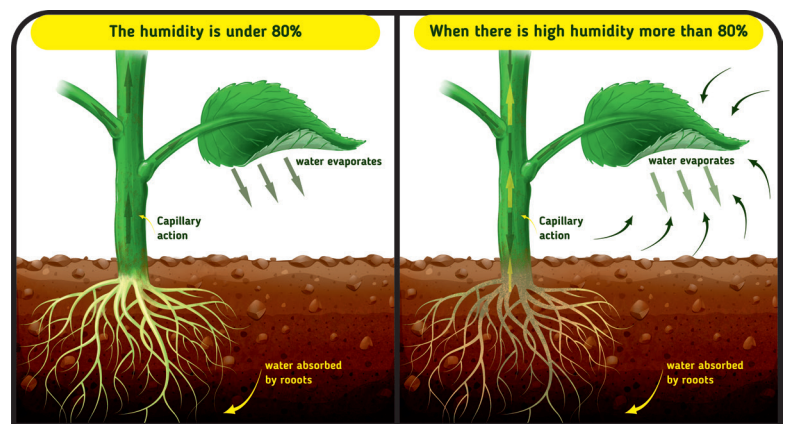

GAHU with compressor and desiccant which can reach 400 lt /h dehumidification capacity in a single device when required, can be used comfortably in very large seedling or greenhouse area thanks to the advantages of communicating with multiple units and being centrally monitored and controlled. Together with fresh air, it will absorb humid air in the greenhouse.

The process consists of a state-of-the-art desiccant rotor and a burner. Water vapor is removed from the air through the rotor and air with low moisture density is released in the greenhouse. Thus, the air inside is heated at the same time.

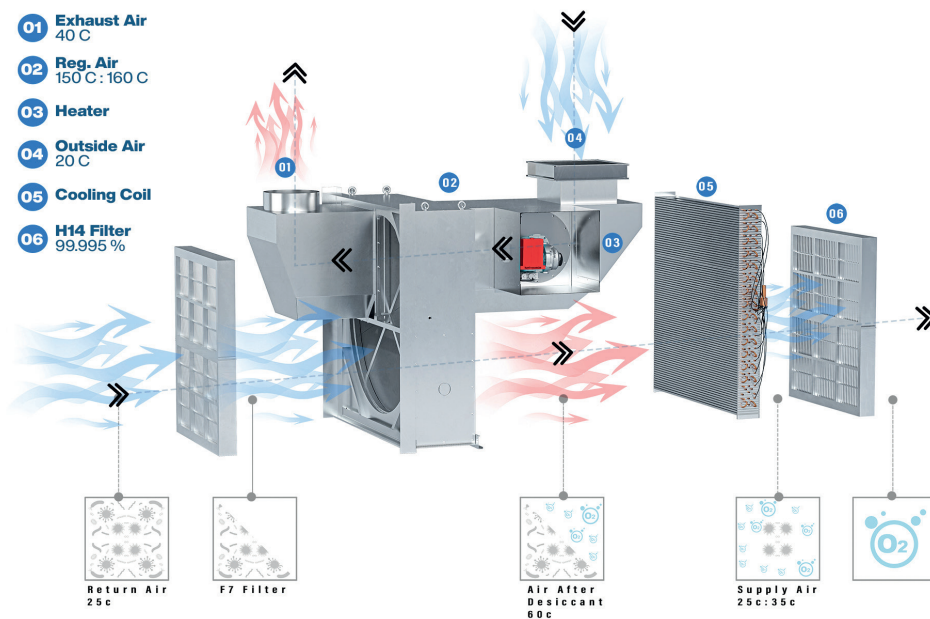

The system is predicated on the principle of taking and heating the air with the help of the rotor. The desiccant Wheel rotates, changing its surfaces between the regeneration zone and the process air. In here, the rotor is heated by the regeneration air so that the humid air is dried and resent to the relevant site-eliminating fungi, bacteria and viruses in the process, distributing homogeneous air for cooling, heating, dehumidifying and ventilation.

When the ait in the greenhouse is warmer than necessary, GAHU's cooling mode is activated, maintaining the temperature at desired levels. GAHU decides on these processes with the data, it receives from the greenhouse and external environment. When the high constant temperature is required. PID provides the desired constant temperature value. In addition, the specific humidity of the air passing through the drum is continuously calculated by GAHU's automation system, beginning with the first start of the burner and a periodic follow up at constantly increasing temperatures.

Certification and Testing

Timfog's quality management system is ISO 9001 certified, ensuring ongoing compliance, meaning that the customer requirements are identified and that the design of the product meets the requirements.

Timfog GAHU devices are tested against conformity with the technical requirements of 2006/42/EC and 2014/35/EU by an independent 3rd party. The devices are always tested before leaving the factory to ensure trouble-free operation. This ensures reliable performance in the field.



CANNABIS

Cannabis Air Conditioning Systems

Whether it is Cannabis Sativa or Indica, it needs special air-conditioning systems to be used in medicine. Climatic conditions must be handled sensitively, whether in covered or indoor growing. Depending on the climatic conditions of the growing region and the growing country, special air conditioning systems are developed. Below, we will talk about how the air-conditioning equipment Keyway-Timfog makes and uses are specific to cannabis.

- **Plastic Greenhouse Fog**

Fogging is the product from which Timfog takes its name. When this product is used on the cannabis plant, various adjustments are made to prevent the greenhouse exhaust fans and the vents where the outside air is drawn in from being exposed to different climatic conditions. For example, the nozzle frequency, line spacing, and angle of the nozzles on the tube are changed. In this way, one tries to eliminate the temperature difference caused by the radiation gradient of the sun in the greenhouse and achieve a homogeneous course.

- **Semi-Closed Greenhouse - Completely Covered Greenhouse GAHU [Greenhouse Air Handling Unit]**

GAHU [Greenhouse Air Handling Unit] can be connected to the climate corridor in Semi-Enclosed Greenhouse structures, or GAHU can operate as a stand-alone unit integrated into the curtain to form a fully enclosed greenhouse. GAHU is designed for maximum energy efficiency due to its operating principle and its unique algorithm. However, it cannot reduce the work to be done. Therefore, combining cooling and dehumidification with curtains may be possible to limit energy gain during the day. This, of course, would require much more energy than evaporative cooling during the day [fog or fan and pillow]. However, it also allows for climate control that combines humidity and temperature control that is completely disconnected from the outside air and almost wholly reduces the use of fungicides and pesticides. In short, it is possible to size the GAHU in two stages.





Since the first solution has lower energy consumption than the second one, it will come first in initial investment and operating costs. However, CO₂ cannot be supplied and requires constant circulation of outdoor air for evaporative cooling during the day, allowing various biological factors present in the atmosphere and undesirable in production to be transported via the air. If you use GAHU entirely, the greenhouse is also suitable for some kind of indoor cultivation.

- **Completely Closed Environment [Indoor] GAHU [Greenhouse Air Handling Unit]**

GAHU is indisputably the only indispensable solution for “indoor” cultivation in a completely closed environment. With its VPD-based algorithm that adapts according to the reactions of the plant, equipped with special filtering and allowing the supply of fresh air and CO₂ or responding to the lighting regime, GAHU is the only device that meets the needs not only of cannabis but also of anyone who wants to grow indoors. GAHU differs from conventional air conditioners in its structure, prioritizing the plant’s needs for years during the development phase on site. Conventional air conditioners do not have a control system that understands the requirements of plants. In nature, for centuries, there have been no plants that have a constant temperature and relative humidity throughout the year. Therefore, GAHU supports the plant with the necessary conditions, just as in nature, adapting to the changing conditions of the plant.

The purpose of the existence of GAHU is to remove the pressure of climate adaptation on the producer. Farmers working with GAHU can focus on other variables by keeping the climate stable and finding ways to manage nutrition and other conditions better to improve production in each new cycle.

VENTILATION SYSTEMS



High Corrosion Resistance:

The fans of the GCF series, with their corrosion-resistant Magnelis plates, belong to the category of very durable fans. Thanks to the self-repairing property of Magnelis, no traces of corrosion can be seen on the surfaces of the fan blades even after many years.

Strong airflow:

The GCF series fans have a specially designed 7-blade propeller structure with a large pitch. Thanks to this feature, it has an average airflow of 7,000 m³/h. Compared to its closest competitors, it offers 20% to 37% more airflow.

Low energy consumption:

According to European energy standards, they are highly effective with their electric motor structure of 0.25 kW, energy class IE -3, and low energy class.

Low noise and vibration level:

The GCF-50, one of the lowest vibration and noise level greenhouse circulating fans in Europe, is used in dozens of greenhouses in different countries with its compact design.

Greenhouse Circulation Fans

Greenhouse circulation fans circulate conditioned air in the greenhouse, providing a homogeneous climate in the environment. Timfog GCF-50 circulating fans are distinguished by their superior characteristics compared to other European competitors and other competitors.

Auto-Work Together feature:

They offer very high energy savings with their automatic cooperation function in sectors with regionally similar climatic conditions. The system activated depending on the desired setpoints for CO₂, temperature, or humidity in the greenhouse can communicate with the central greenhouse controller. Thanks to its ability to communicate with other Timfog devices, such as the fog system, the heating system, and the fan-pad system, it is also easier to get all the data about the greenhouse using the same sensors.





Greenhouse Exhaust Fans

The exhaust fans (TEF -140) manufactured by Timfog have the following excellent characteristics;

- They are easy to install and have low maintenance thanks to their durable structures. The fan cowl and venturi are made of hard galvanized sheet steel.
- They have optimal energy and performance thanks to the perfect design and aerodynamic structures of the propeller.
- Thanks to the uniform structure of the air intake louvers, they have a more uniform air intake and almost 100% closing performance.
- The bottom bracket and the V-belt pulley are made of cast aluminum.
- All fan equipment is manufactured with aging tests and longevity analysis.
- The TEF -140 is an ideal exhaust fan when extra-high airflow capacity is required.





IRRIGATION, FERTILIZATION AND AUTOMATION



IRRIGATION AND FERTILIZATION SYSTEMS

Irrigation is the supply of water, which the plant does not receive through natural precipitation, to the plant's root zone by various methods. Greenhouse irrigation is the delivery of water needed for plant growth to the soil through various systems. To perform good irrigation, you need to choose the irrigation method according to the characteristics of the plant and the soil. Then you need to know when, how much and how to give water.

Drip irrigation is a method of dripping purified water and fertilizer onto the soil surface at short intervals under low pressure. In this method, the water can be directed to each plant through a common network of pipes. Drippers reduce the pressure in the piping network with a small orifice or a long flow path, allowing a small flow of several liters per hour.



Plant nutrients are used for the substances that plants absorb from the environment for their development, fertilizers are used for the substances that contain plant nutrients, and fertilization is used for the process of adding them to the plant's growing medium. The purpose of fertilization is not only to release the nutrients needed by the plant into the environment but also to protect the plant's growing environment and increase its productivity.

In collaboration with Keyway's expert agricultural engineers and agricultural consultants, it ensures the selection of the most appropriate cultivation method, along with parameters such as region, temperature, light, depending on the targeted plants. For this, a correct irrigation and fertilization system, a machine, and a well-designed drip irrigation system are essential. Keyway project engineers provide 365-day maintenance and service for the world's best irrigation and fertilization equipment.





Fertilization automation systems, used in greenhouse irrigation automation and outdoor irrigation, deliver the acid and fertilizer solution taken from the fertilizer tanks to the mixing tank as needed through a two-way valve system. When the values it receives from the sensors on it reach the set limits, it stops the flow to the tank. With this system, dosing is immediate and more precise. By premixing water and fertilizer with the fertilizer tank system, you get a homogeneous plant nutrient solution.

Irrigation tanks are the tanks established to store the water needed in the greenhouse. Generally, it is intended to install a tank equal to 2 days of water needs. The round steel is covered with PVC or PE film and covered with anti-moss tarpaulin. Silos can be delivered as building kits or fully assembled on-site, including excavation. The general uses of steel water tanks are clean water storage, drainage water collection, rainwater collection, fertilizer solution production, and softened water storage.



Fertilizer Tanks ensure that our plants receive the nutrients and rich fertilizers they need by mixing them in large mixing tanks. Liquid fertilizers used in greenhouses have many advantages, but despite these advantages, liquid fertilizers should be used and chosen with great care.



GREENHOUSE AUTOMATION SYSTEMS

Today, modern greenhouses are increasingly turning into giant industrial enterprises. Of course, controls in these industrial companies are becoming more thorough and critical to the company's efficiency. The modern greenhouse adventure that began about 50 years ago has evolved into total automation, with dozens of sensors and processes intertwined. In the last 20 years, in addition to the concepts of temperature and humidity for outdoor and indoor air, the idea of VPD (vapor pressure difference) has been added to these definitions. Other parameters must be considered today, along with the moisture of the plant beds and the pH balance of water and liquid fertilizer, which control irrigation fertilizers.



It is now important to perform the “PLANT-EQUIPMENT-HUMAN” controls in the greenhouse with an integrated automation module. It is no longer enough to control only some plant or greenhouse environment values, such as outdoor humidity or temperature. Apart from that, a system where all the equipment controls and maintenance of the company are monitored, the tasks and performance of the employees are determined, the energy and other expenses by tracking the cost of the seedlings purchased, which are the other inputs of the company, etc., shows us how much profit or loss the company actually makes at the end of the day.

It is now possible to monitor the daily activities of employees, crop performance, company profitability based on seasonal prices of the product sold, monitor the harvest trucks, spray trucks, and other mobile vehicles in use to determine user performance and make these processes more efficient by monitoring business processes such as increasingly automated product pickup, plant care, product crating and product transfer. Without following this entire process, the inefficiencies of ever-expanding greenhouse operations and competition without continuous improvement will result in severe monetary losses and the exclusion of investors from local, then regional, and global markets.



GREENHOUSE AUTOMATION SYSTEMS

PLANT

Indoor Sensors (Indoor air temperature, Relative humidity, Vapor Pressure Deficit (VPD), Photosynthetic radiation (PAR), CO₂, Leaf temperature, Plant gutter humidity, pH (Water-Fertilization)),
Outdoor Sensors (Outdoor air temperature, Relative humidity, Solar radiation, Wind velocity, Wind direction, Amount of rainfall).

EQUIPMENT

Heating System (Boilers, burners, pumps, 2 way and 3 way valves),
Ventilation System (Roof windows, air circulation fans, exhaust fans, fan-pad systems),
Cooling, Humidifying and Dehumidifying Systems (High pressure fogging systems, dehumidifiers, greenhouse air handling units),
Irrigation and Fertilization System (Irrigation system, fertilization system, reverse osmos systems),
Climate Screens and Driving Systems,
CO₂ Systems (Condensers, CO₂ fans, buffer tanks),
Harvesting and Disinfestation Trucks,
Lamps and other electrical equipments,
Doors and Hygiene Tourniquets.



HUMAN

Sales and Marketing,
Supply Chain (Resource planning, production, purchasing, shipping),
Quality assurance,
Accounting and finance,
Harvest monitoring (Plant health),
Labor monitoring,
Periodic maintenance tracking.

ELECTRICAL SYSTEMS

Ventilation motors wiring, pans, panels; curtain motors wiring, pans, panels; circulation Fans wiring, pans, panels, packaging plant lighting and electricity are all under our commitment.

- At certain distances on the greenhouse concrete road, in a combination box on both poles, there are Monophase and three-phase socket connections.
- Main standing type panel at the greenhouse entrance door (Thermal Magnetic Conditional according to the power of the greenhouse, W automat, K automat outputs to be released, pre-monitoring power control relays).
- Separate outputs for heating, irrigation, fogging, lighting (greenhouse ventilation motors, curtain motors, fans) and water treatment in the standing type panel.
- A phase sequence motor protection relay must be installed against phase sequence faults in the reducer and the system.
- Cables are used in XLPE.
- Contactors With Eaton, locking mechanism, reverse and straight direction operations are protected both mechanically and electrically.



With the maintenance switch placed at the entrance of each fan, the maintenance of the fans is carried out safely.

- Automation devices are Eaton.
- The whole system can be controlled automatically and manually on the panel.
- The main electrical panel shall be in CE norms and there shall be motor protection, contactor groups and relay groups for computer control for all motors in the greenhouse.
- All cables to be used in the greenhouse shall be carried in wire trays on the central service.
- There will be 20% spare contactor places on the electrical panel for future additions road.
- There shall be control switches for ventilation motors, circulation fans, shading system and heating system, as well as switch groups for manual and automatic use.
- All signal cables from the sensors are selected to be unaffected by LICY harmonic effects. Roof and curtain motors have limit switches





GERMINATION AND COLD ROOMS

The cooling devices used in the germination rooms are produced by Timfog firm and they are specially designed. Special heating module that keeps the inside of the laundry room at 15/20 C by heating in the winter season is one of the distinguishing sides of our Timfog germination devices. In addition, with high pressure humidification modules in the room, desired humidity of 90-95% is achieved.

These cold rooms, which are isolated with the help of special polyurethane panels, provide high energy saving.



Superior features of the Timfog germination room;

- Sensitive cooling devices,
- High quality cold room polyurethane panels and cold room doors,
- High pressure humidification feature,
- High pressure line spreading all around the room,
- Heating feature in the winter session,
- Control of cooling-humidification and heating features with a single control panel,
- Homogeneous air distribution with in-room special evaporator fans.



REVERSE OSMOSIS SYSTEMS

Since the 1990s, the Reverse Osmosis system has been used in many advanced agricultural countries. Reverse Osmosis (Reverse Osmosis) System is the membrane filtration method for pure water production, which separates all unwanted minerals in water from which conventional treatment systems are inadequate for agricultural production.



This system removes the solids, minerals and microorganisms in the ratio of 92-98% with the help of the semi-permeable membrane of the water under high pressure and provides clean water production and helps to send this water back to the system with the fertilization system.



GH HARVESTING, HARVESTING & DISINFESTATION TRUCKS

Today, it is used for the cultivation of plants in modern greenhouses, which are spreading rapidly. According to the growth rate of plants, it is used for dilution, leaf picking, rope winding of the plant for faster and more efficient production.

It is used for transporting the products grown in greenhouses after they are crated during harvesting. Products can be designed according to requested crate sizes.

It is one of the most important tools of our breeding process. It helps us to keep plants in top condition by using preservatives. Both automatic and manual spraying tools are used to facilitate plant protection. Significant savings are achieved by automating pharmaceutical activities. With the right product selection, it can be less affected by environmental impacts and more efficient and safer production can be achieved.

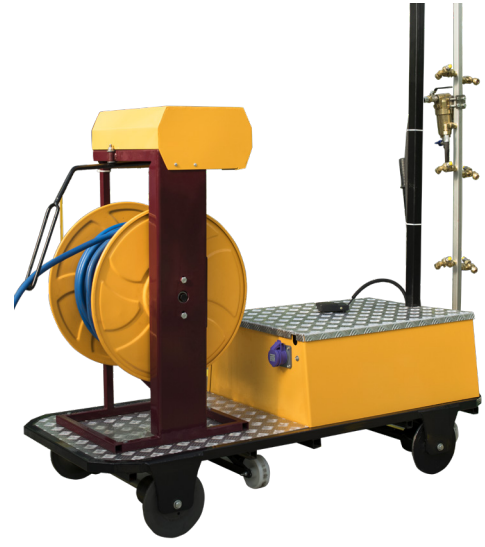

DOORS AND HYGIENE TOURNIQUETS /STATIONS

Doors are the structural elements that provide entry and exit to the greenhouse. Due to the big sizes of the greenhouses built in recent years, automatic transfer doors have become a necessity. When using double doors or sliding doors (these doors have all aluminum frames) in production areas, these doors should be made of transparent materials as in greenhouse coverings. In large greenhouses, doors are made as double-wing or sliding in 2.40 x 2.20 m dimensions. The doors are designed to prevent infiltration. Sectional doors are used for fast and effective loading in loading raps.



HYGIENE TOURNIQUET

When bacteria or other plant pathogens enter products, these can cause big problems. To avoid this, we need to create a hygienic environment so that employees or other visitors do not spread these bacterias in the product. For optimal hygiene, we need to make the most of a complete hygiene station. We need to wash hands with soap, dry hands, disinfect hands, clean the shoes and disinfect the soles.

For this reason, we need hygiene tourniquets when entering the production areas of the greenhouses and we need to enter the greenhouse after passing through these units.



RAIN WATER COLLECTION SYSTEMS

Rain water is essentially a source of condensed water vapor from the sky, which allows us to use it as a very high quality water source contaminated with biological, chemical and physical substances after hitting the collection surface and draining it to the drain pipes. For this reason, water quality may need to be improved with water treatment systems.

It is possible to collect rain water in pools or steel water tanks by means of roof gutters and drain pipes installed in the greenhouse top construction, so water consumption can be prevented and contributed to the economy.



PLANT GROWING GUTTERS

Product growing gutters provide many benefits. Due to the increasing demand in the greenhouse sector, it is used in many fields today. For example; for roses, gerberas, orchids and berries. There has been a serious increase in demand for plant beds for tomatoes in recent years.

The same type of growing gutters are also designed to use together with peppers, eggplants and cucumbers. With the use of this system, many positive results began to be obtained.



- Since the products are grown in gutters instead of soil, they are at a certain height so that they can be processed more easily.
- Recycling of drainage water
- Easier control over plant growing conditions
- Plants no longer depending on soil conditions
- Reduction of plant disease risk
- Easier to maintain hygiene conditions
- Excellent waterproof system with field application
- Due to hanger systems, plants do not touch the ground.



PLANT GROWING ENVIRONMENT

PERLITE

Perlite; is a volcanic and glassy mine and there are water particles trapped in its natural structure.

During production; perlite, heated to 800 - 1200 ° C in special ovens, explodes into a porous structure with the sudden evaporation of water particles inside it explodes like pop corn. At the end of this process, it expands to 4 - 20 times its volume and its density decreases considerably. Thanks to the porous structure and flammability of expanded perlite; it can mainly be used in construction, aggregate, agriculture, food and filtration.

At present the benefits of this natural mineral that continue to be discovered and 65% of reserves are located in the territory of Turkey.

- It provides savings in irrigation, vitamins and minerals with its high liquid holding capacity
- Improves aeration and drainage for roots.
- It is organic and does not decay.
- It is natural and neutral pH ratio: 7 ± 0.5
- Sterile, healthy; free of wild herbs and disease.
- It is economical. Can be used again and again
- It is light; Easy to carry and work with.
- Its porous and insulating structure provides energy efficiency by maintaining ambient temperature.

COCOPEAT

Cocopeat's raw material is the outer shell surrounding Coconut. This shell is fibrous and soft. Today, these fibers are widely used in greenhouses.

- It is made up of 100% organic materials.
- It contains 31% lignin
- It contains 27% cellulose
- The pH value is between 5.7 – 6.5
- EC 180 $\mu\text{S}/\text{cm}$
- Cation exchange capacity is very high
- The carbon-nitrogen ratio is 104: 1. This indicates the slow rate of degradation of cocopeat.
- Absorbs water and nutrients 8-9 times its own dry weight and transmits to the plant as needed.
- Porosity rate of Cocopeat is 96%.





ROCKWOOL

It is a natural insulating material formed by melting inorganic stones which are very rich in mineral, obtained from volcanic rocks in nature and melting at 1500-1600 degrees and making them into fibers. It has a high level of protective feature in roofs, in various partition walls, in exterior isolation, in oven isolation, in isolation of steel doors, in ship constructions, in electrical household appliances, in many areas as heat, sound and moisture isolation as well as in all areas requiring fire safety.

Due to its inorganic structure, it does not decay, bacteria and micro organisms cannot grow. Since it is made of natural raw materials. It is ecological and environmentally friendly. Rockwool is a sterile, high water holding capacity, porous and rich in oxygen environment so it absorbs nutrients.

It is preferred in organic farming and greenhouse cultivation in recent years due to its water retaining feature and air flow to the roots.

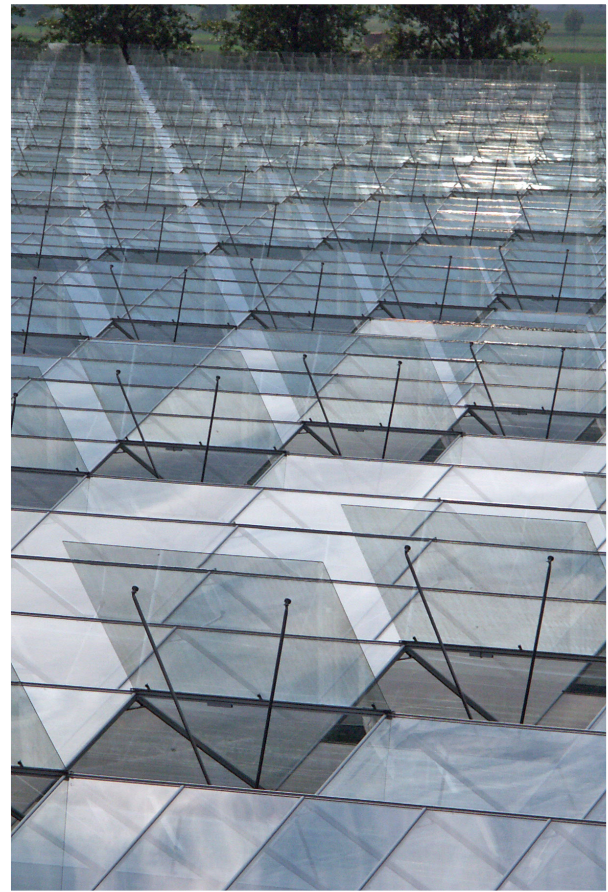

TECHNICAL SUPERVISING

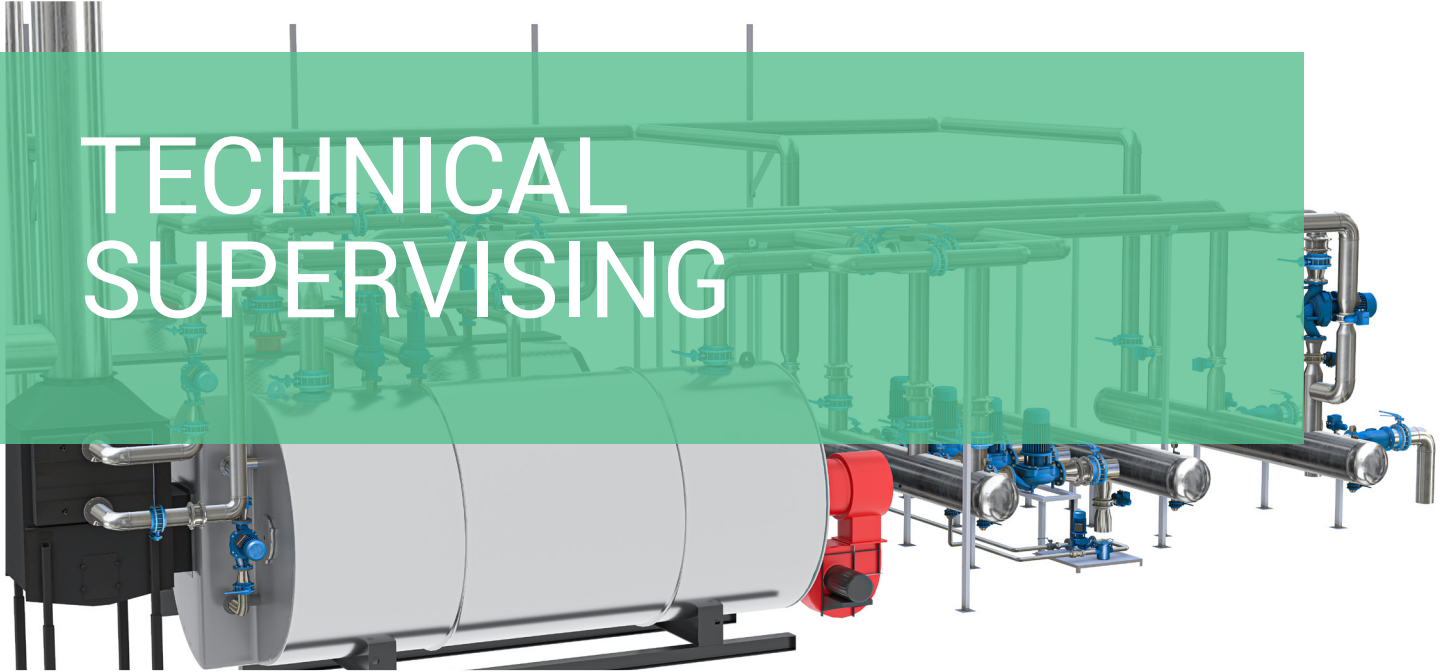

SUPERVISING, SERVICE AND COMMISSIONING

Keyway is also an engineering company based on providing a progressive supervision service. Therefore, it acts with accurate service, correct commissioning and continuous periodical maintenance analysis all over the world.

Multilingual, international service engineers, all English speaking, are on site to solve problems. All technical processes are accurately reported to customers and all concerned, both on site and at headquarters. With the help of the records kept, it is possible to get information about the services and other services provided for each system or machine even after many years.

Keyway has been providing service with its central and national services in more than 50 countries and has been providing reliable systems for years.



Our Project Contracting team, with international experience, diligently performs installation and commissioning of Keyway projects in many different parts of the world. They establish systems that our customers can use for years without any problems, intervening remotely or on-site for all kinds of problems that occur, especially during the period when the greenhouses are put into operation.

The engineers on our contracting team ensure that greenhouse projects are implemented with full precision thanks to the constructive relationship they have established with the technical staff on site. After start-up, greenhouse investors can get fast and high-quality technical support in solving all kinds of technical problems thanks to the establishment of local technical services.





Head Office and Factory

Çerkeşli OSB Mah. İmes 7. Cad.
No:3 Dilovası / Kocaeli / TÜRKİYE

www.keyway.com.tr

An **MCM** Company
ENGINEERING