

**timfog**



# **BUFFER TANK**

## **INSTALLATION MANUAL**

# BUFFER TANK

Installation Manual

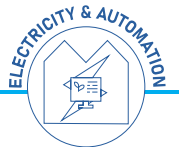
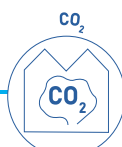
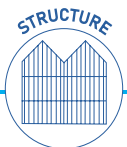

# BUFFER TANK

|     |                           |
|-----|---------------------------|
| CN  | 安装说明                      |
| CRO | Upute za ugradnju         |
| CZ  | Návod k instalaci         |
| DK  | Montagevejledning         |
| E   | Instrucciones de montaje  |
| F   | Instructions de montage   |
| GB  | Installation instructions |
| GR  | Οδηγία συναρμολόγησης     |
| H   | Szerelési utasítás        |
| I   | Istruzioni di montaggio   |
| NL  | Montagehandleiding        |
| P   | Instrução de montagem     |
| S   | Monteringsanvisningz      |
| SER | Uputstvo za montažu       |
| SF  | Asennusohje               |
| SK  | Návod na montáž           |
| SLO | Navodila za montažo       |
| TR  | Montaj talimatı           |
| PL  | Instrukcja montazu        |
| NO  | Installasjonsanvisning    |
| RU  | Указания по установке     |
| ROM | Instrucțiuni de montare   |

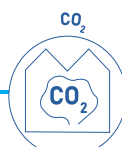



2500 TONS

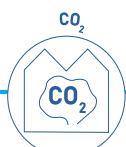
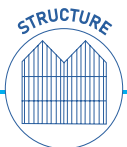

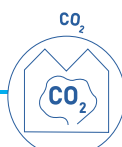
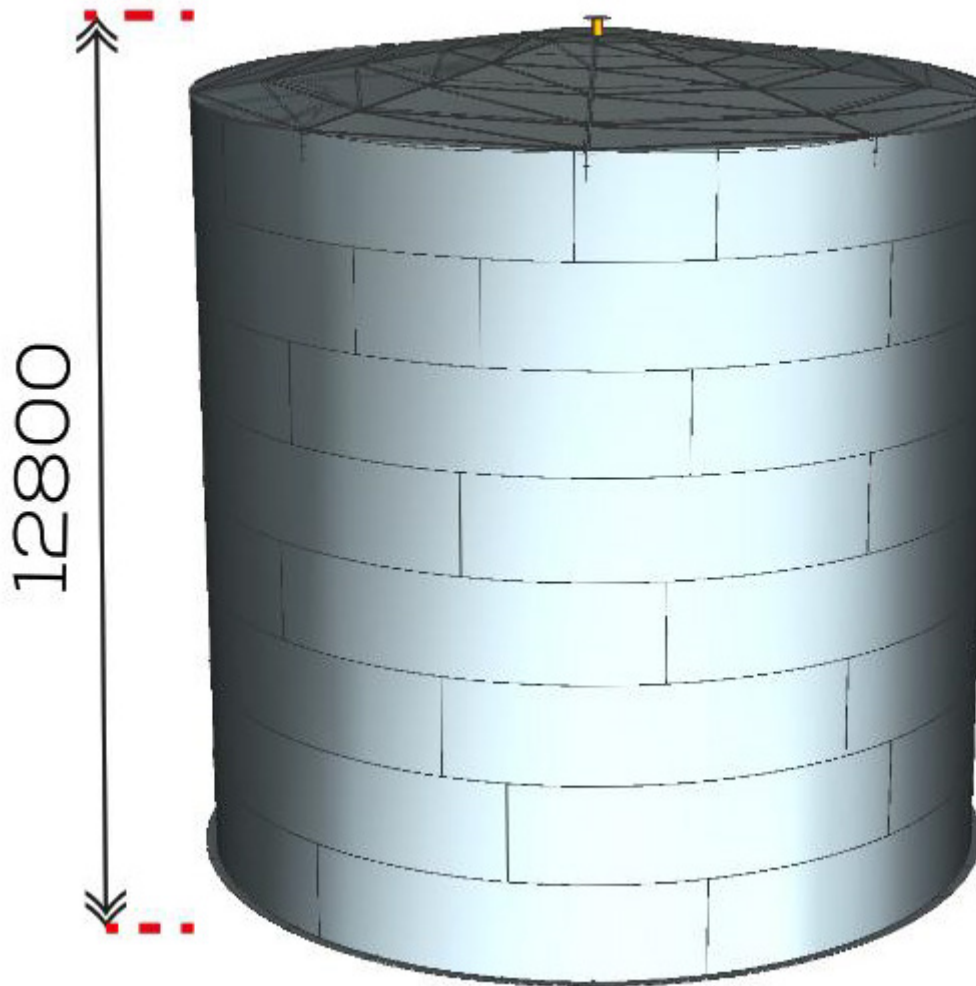

2500 TONS



1. TRUCK



2. TRUCK



3. TRUCK



4. TRUCK

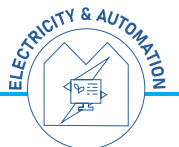
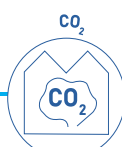
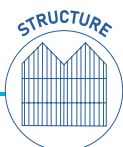

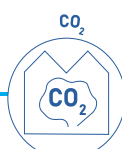
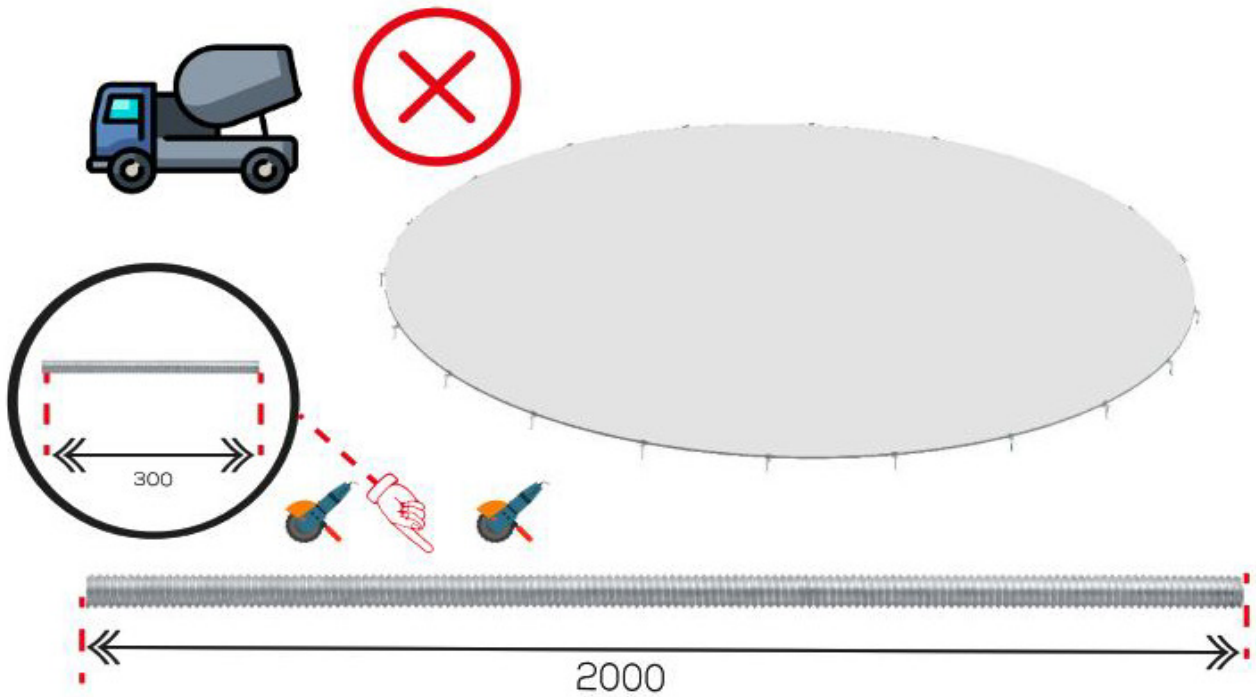
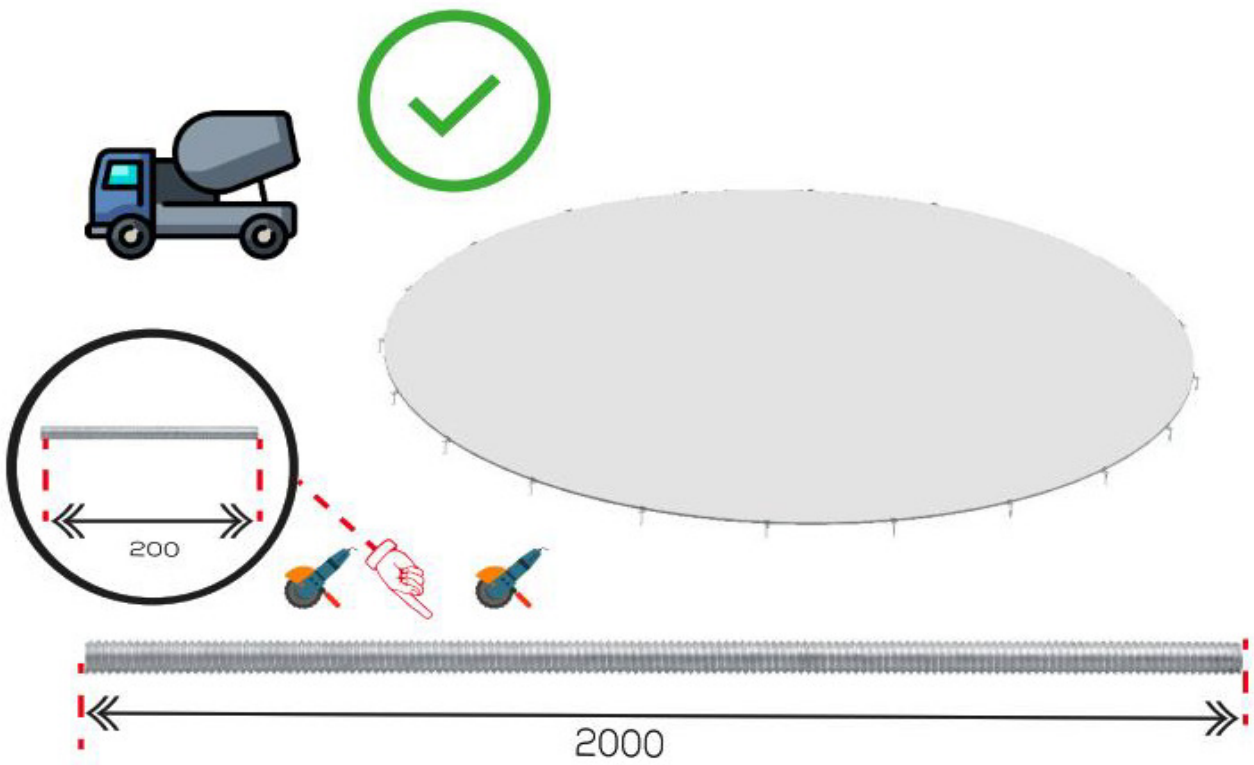

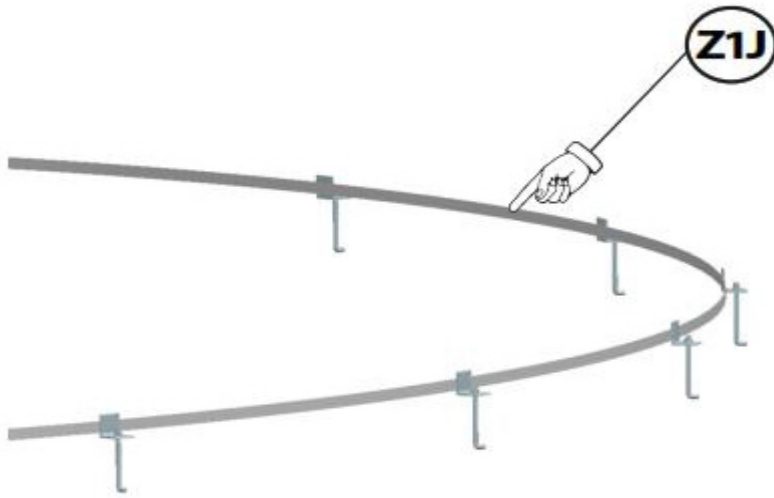
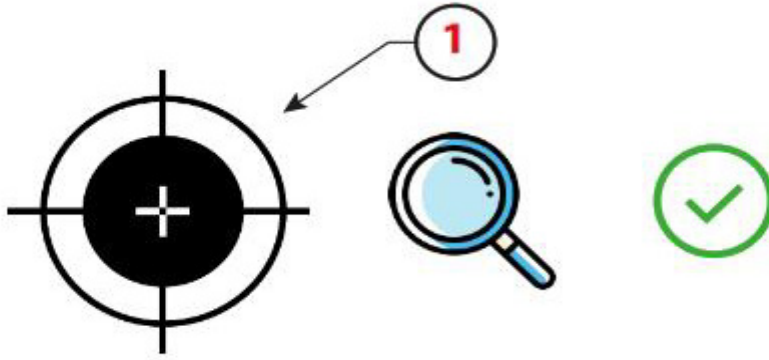

**XPS insulation and oily sand**

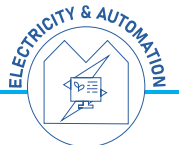
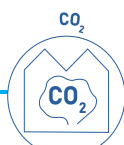
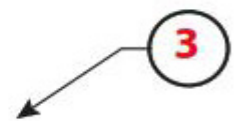
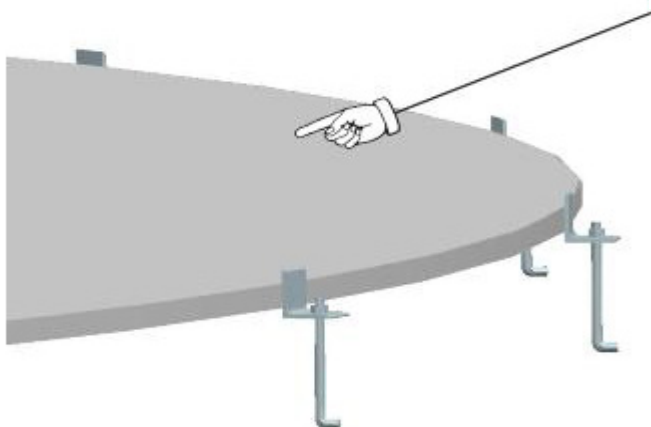

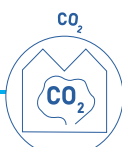
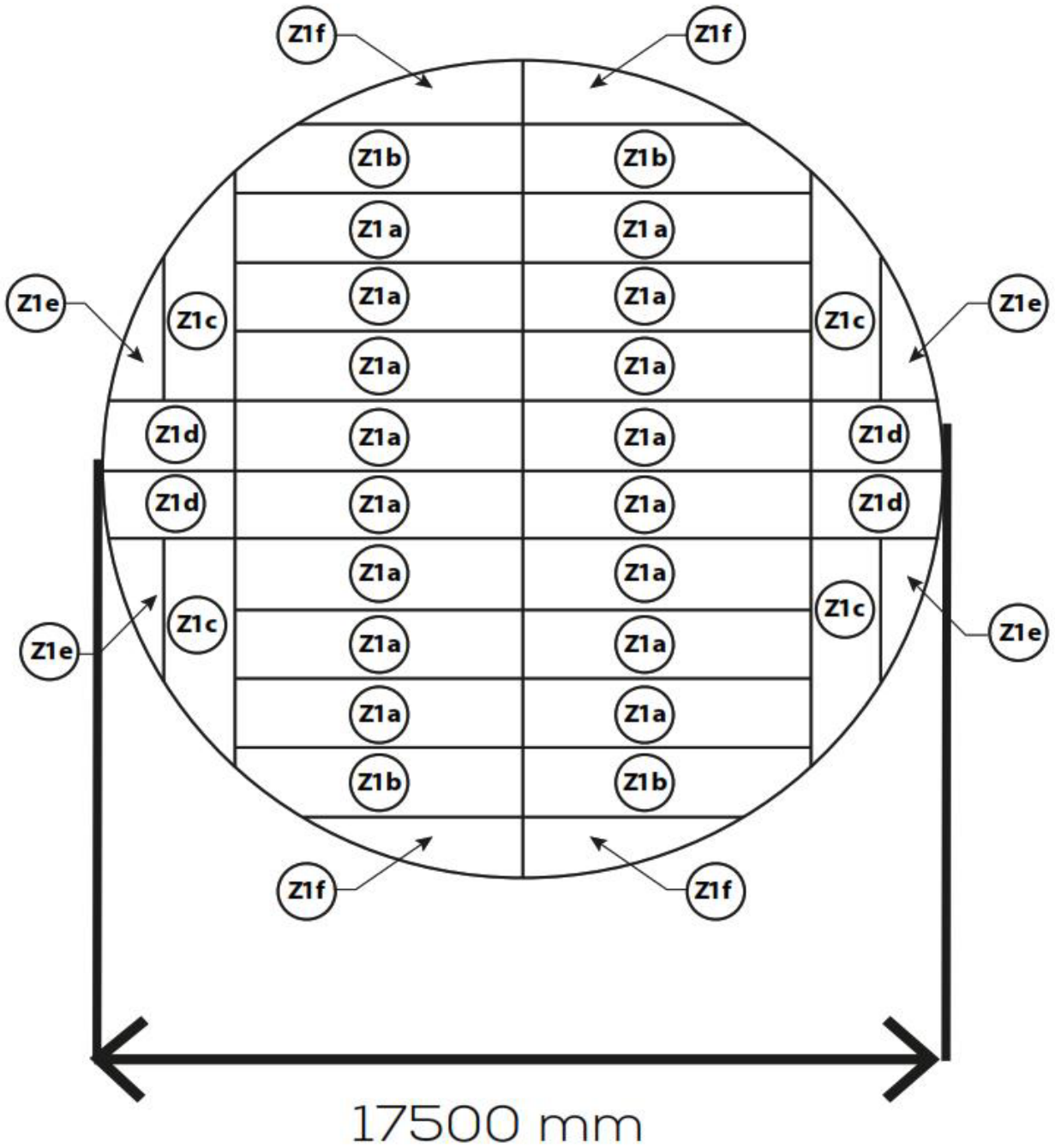

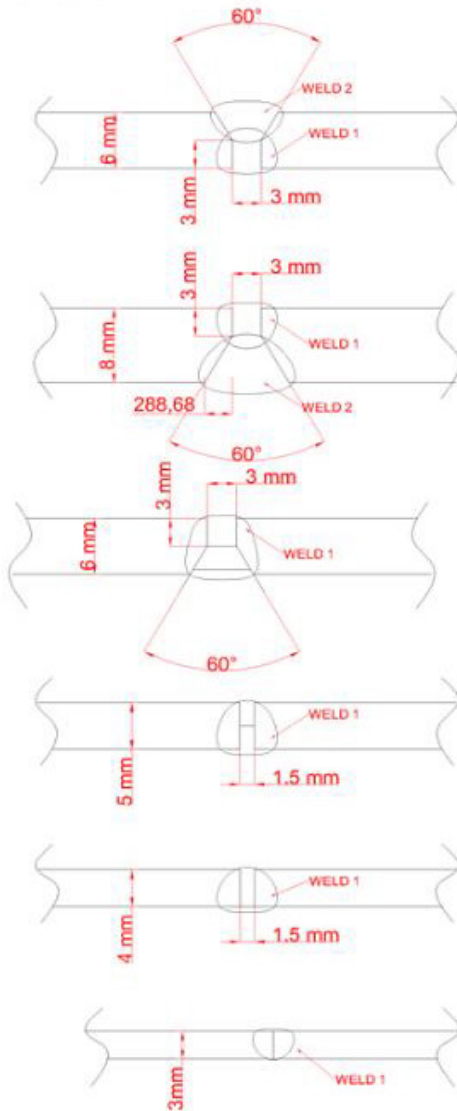
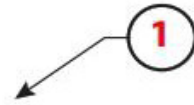

### BOTTOM PLATE WELDING

Weld Groove: Top side  
 Welding: weld 1 = 4 mm – 130A  
 weld 2 = 5 mm – 170A  
 Welding Speed: 5 m/h

### WALL PLATE WELDING

Weld Groove: Outside  
 Welding Direction: Bottom to top  
 Welding: weld 1 = 4 mm – 130A  
 weld 2 = 4 mm – 180A  
 Welding Speed: 3 m/h

### WALL PLATE WELDING

Weld Groove: Outside  
 Welding Direction: Bottom to top  
 Welding: weld 1 = 3.25 mm – 110A  
 Welding Speed: 4.6 m/h

### WALL PLATE WELDING

Weld Groove: None  
 Welding Direction: Bottom to top  
 Welding: weld 1 = 3.25 mm – 110A  
 Welding Speed: 6 m/h

### WALL PLATE WELDING

Weld Groove: None  
 Welding Direction: Bottom to top  
 Welding: weld 1 = 4 mm – 120A  
 Welding Speed: 20 m/h

### TOP PLATE WELDING

Weld Groove: None  
 Welding Direction: weld 1 = 4 mm – 115A  
 Welding Speed: 27 m/h

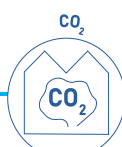
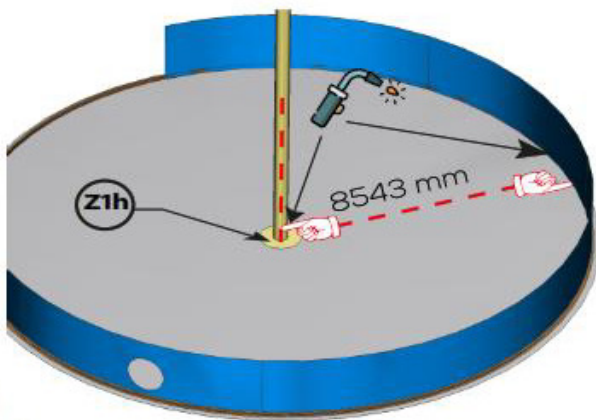

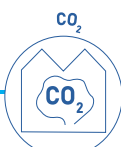
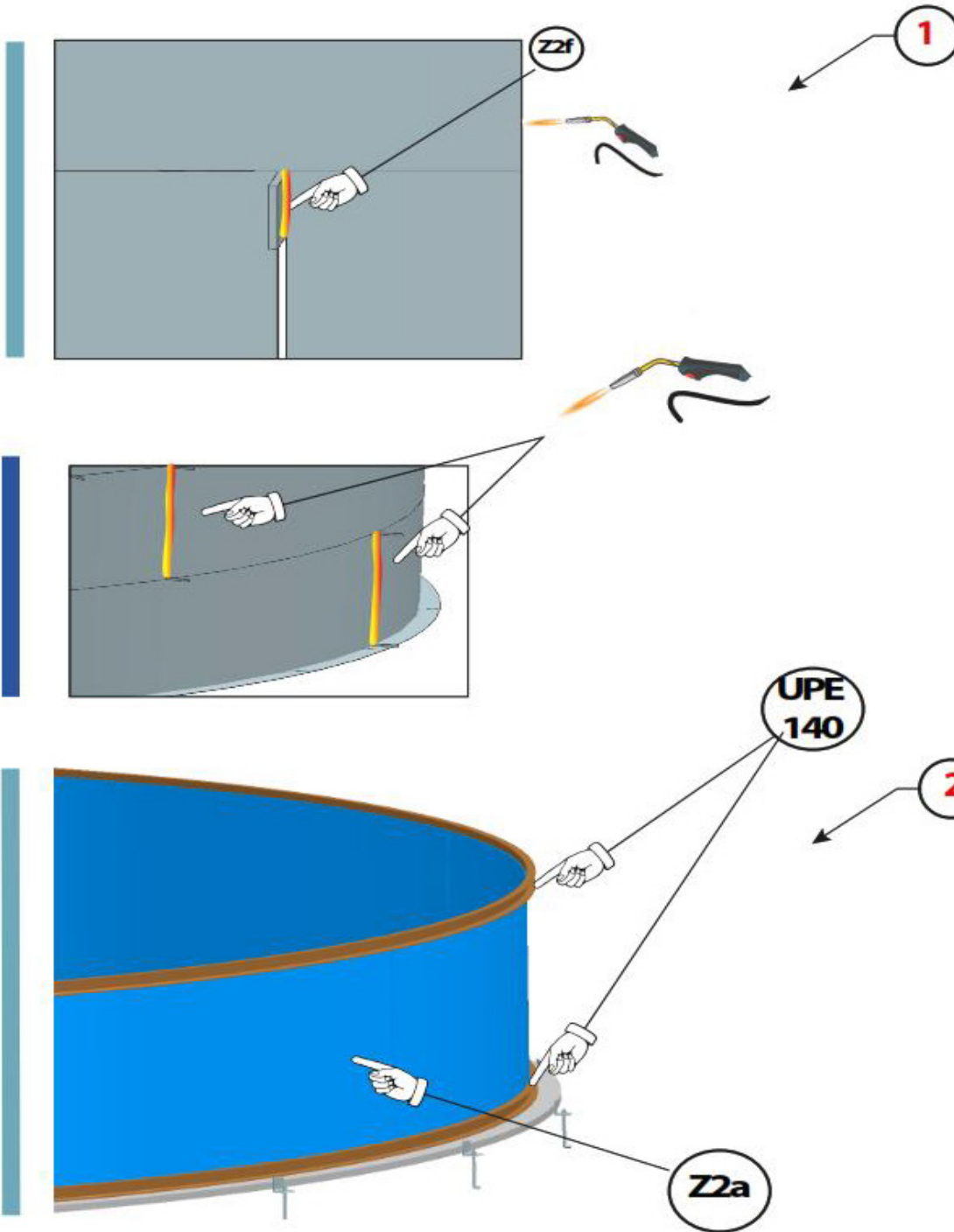

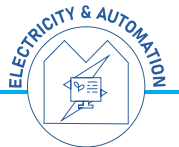
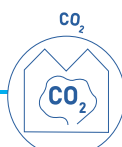
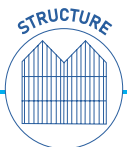
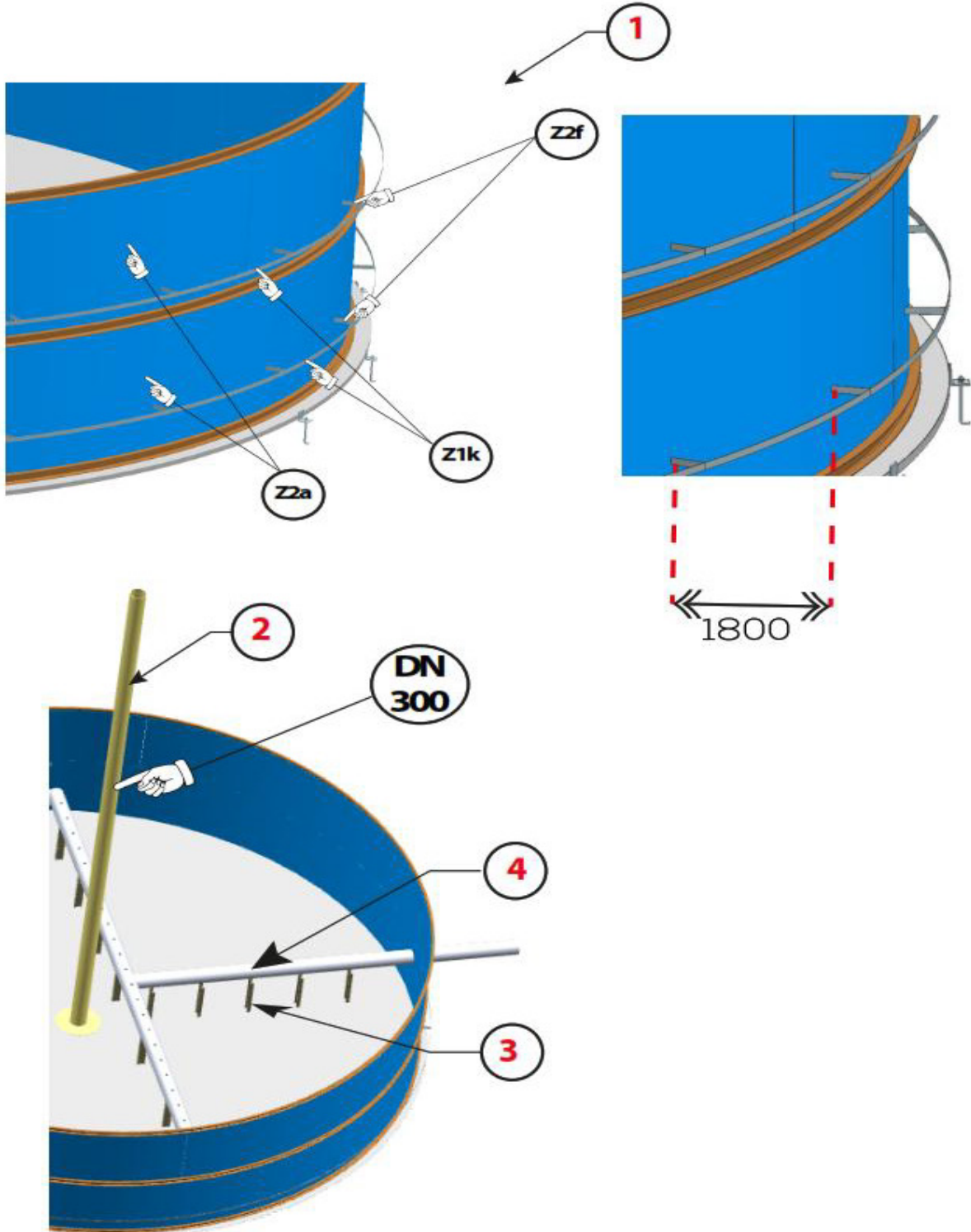

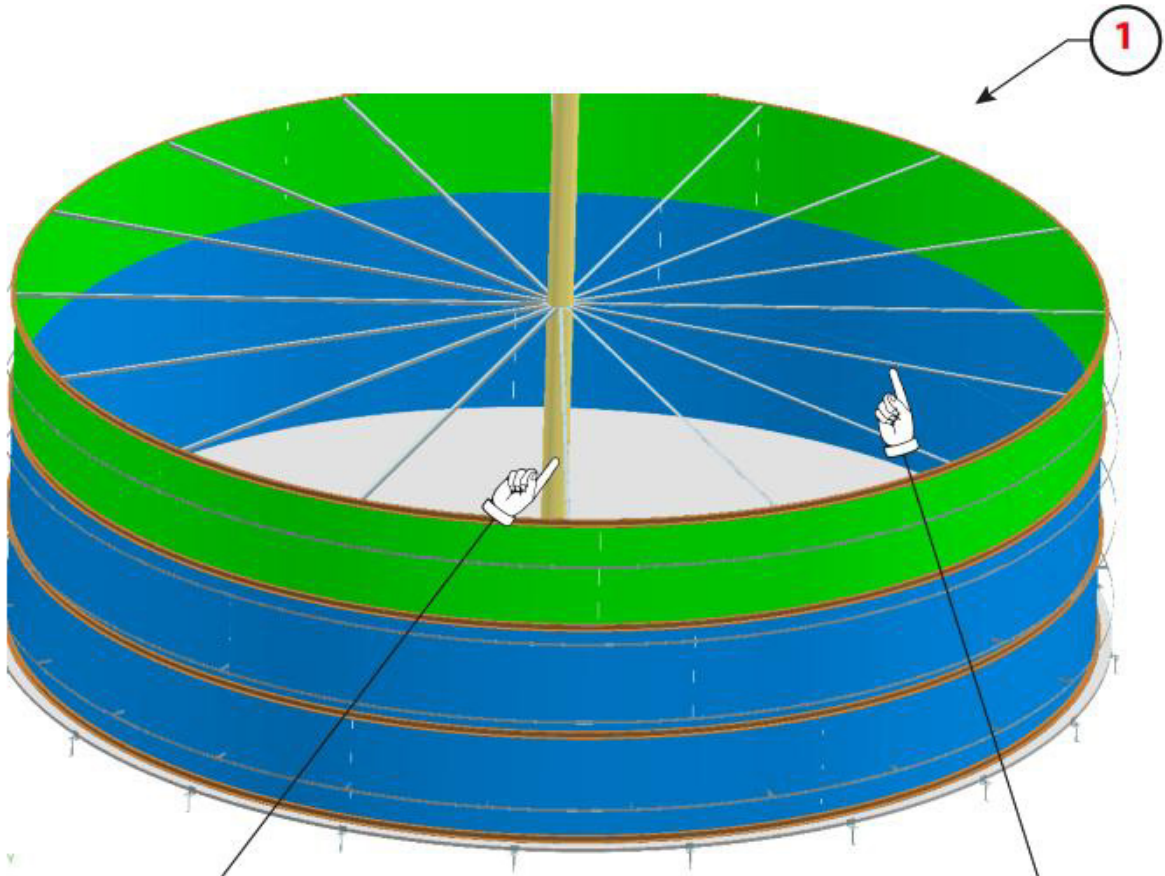

**Z2b**

P1  
50 × 50 L Profile  
16 pieces

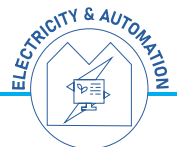
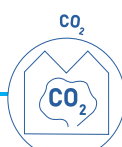



Z1k

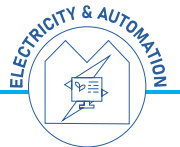
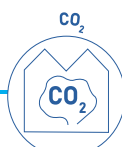
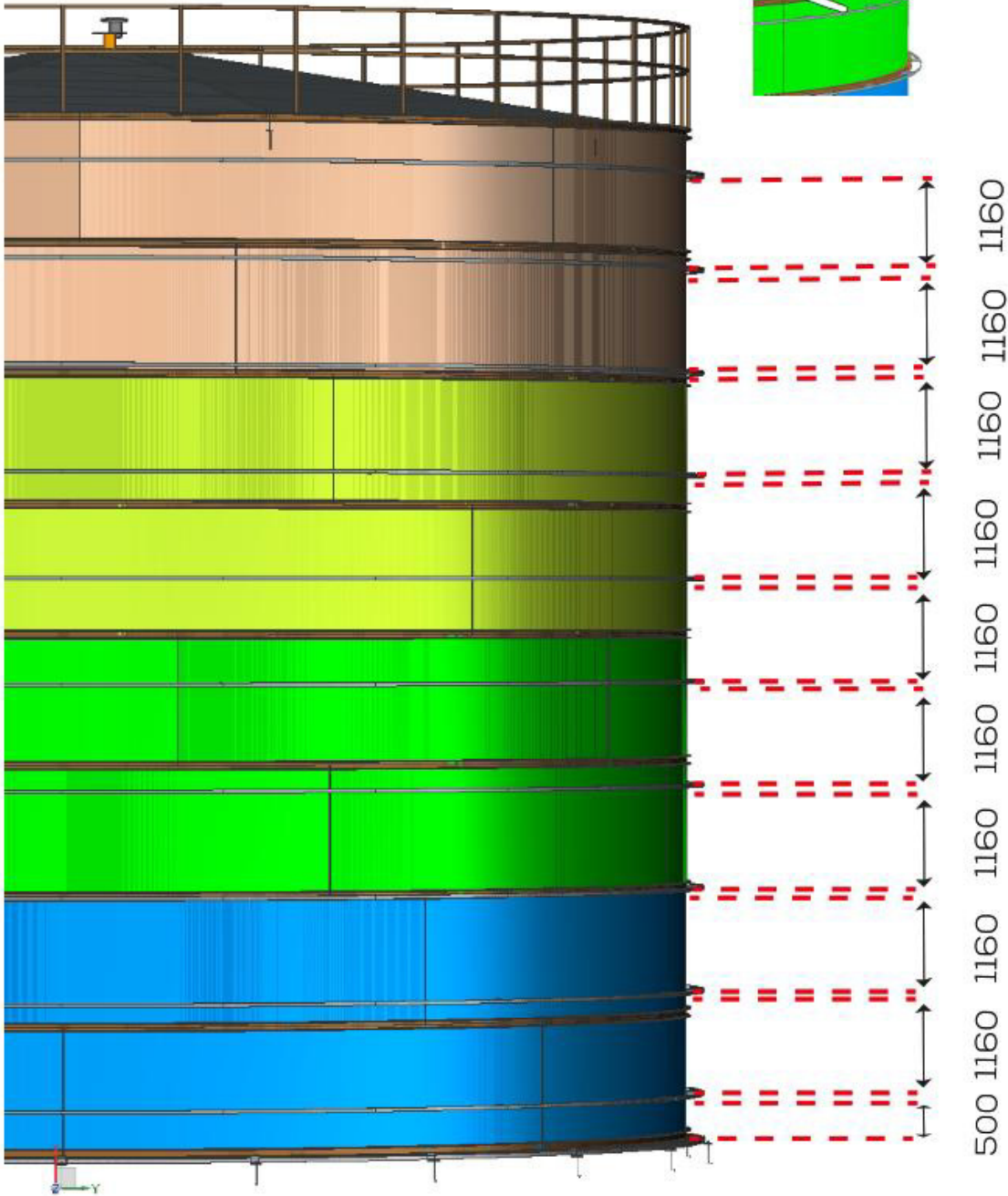
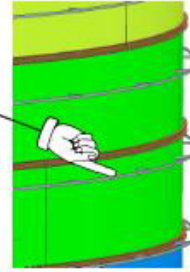

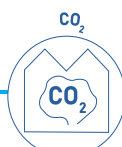
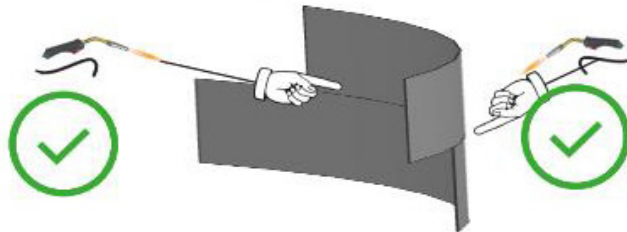
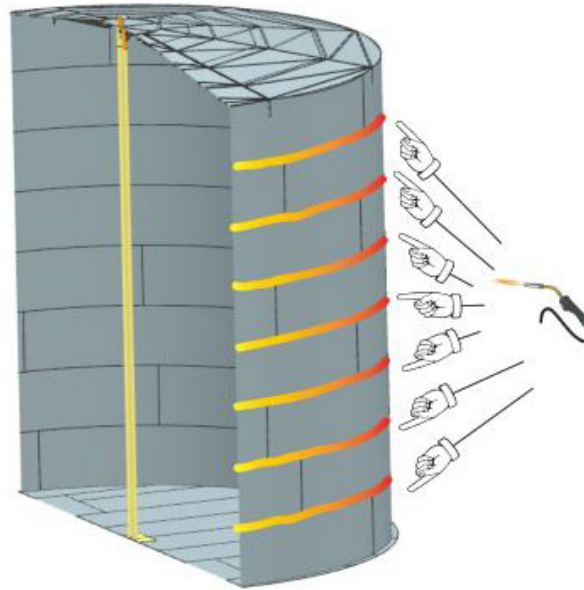
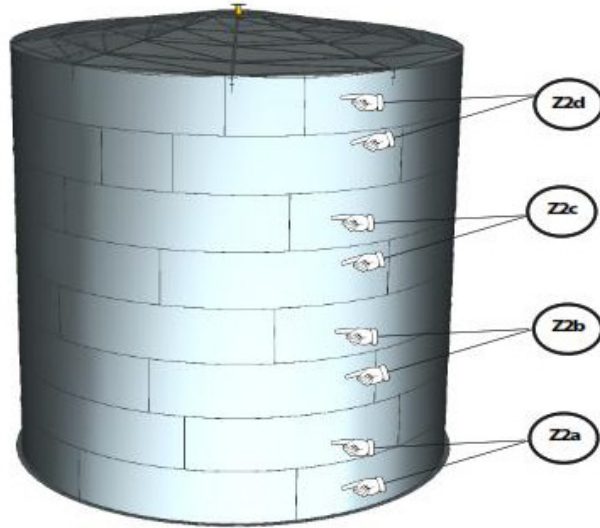

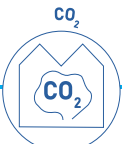
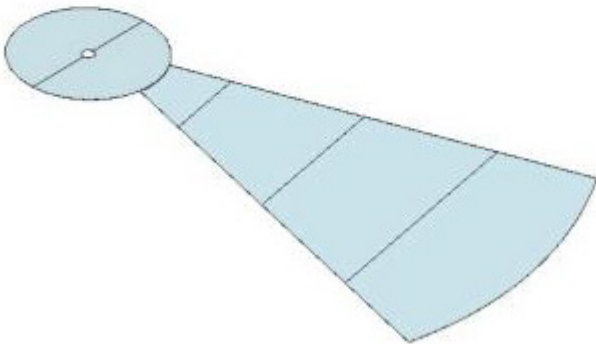
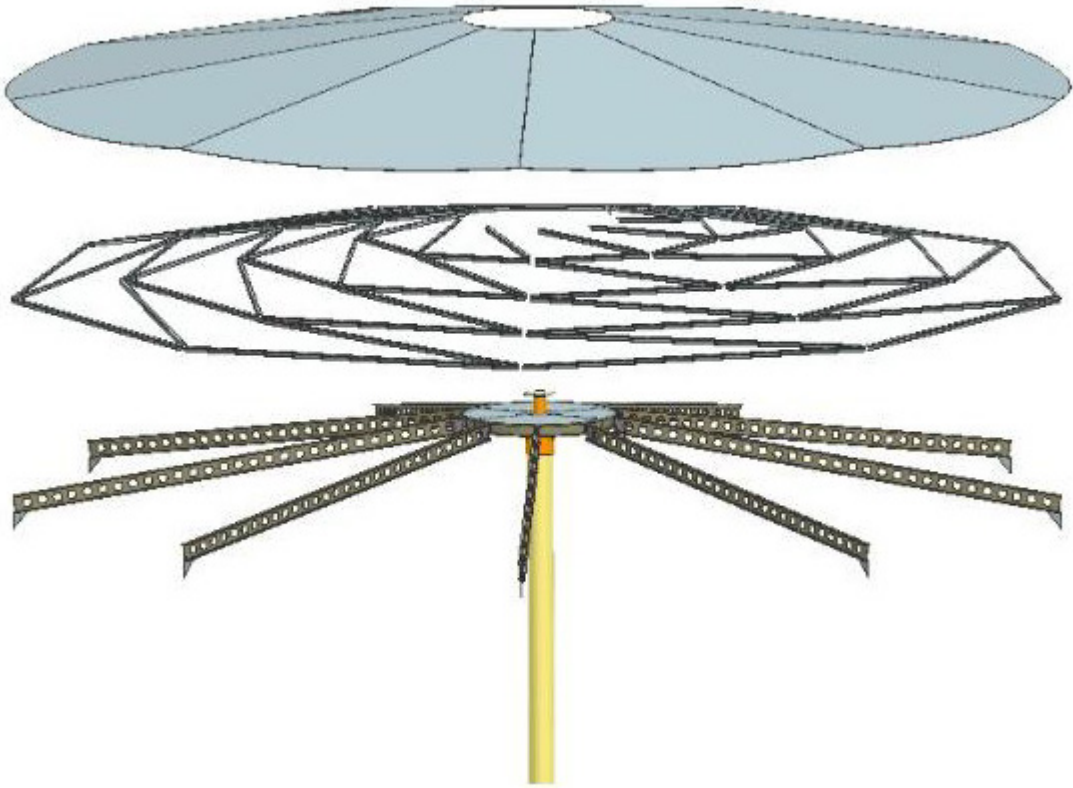

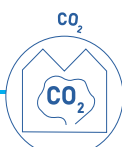
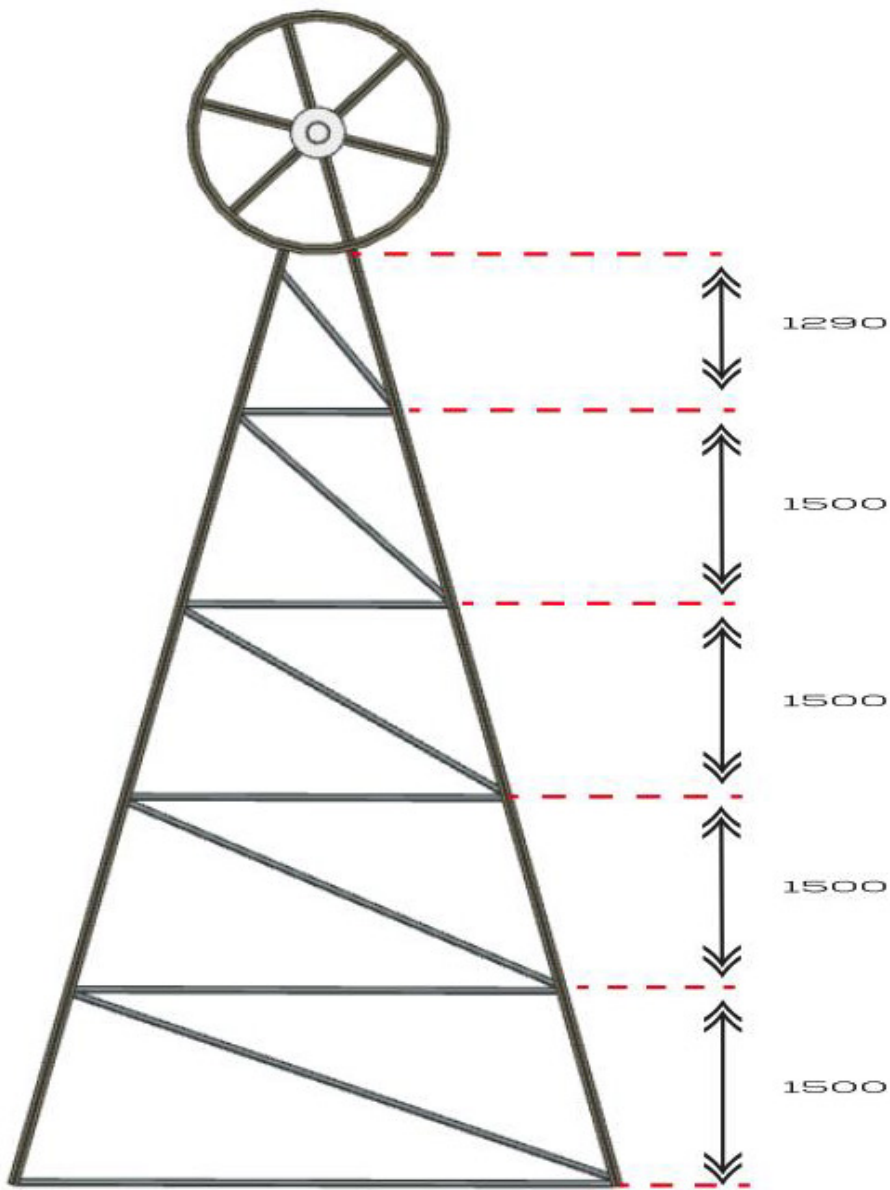
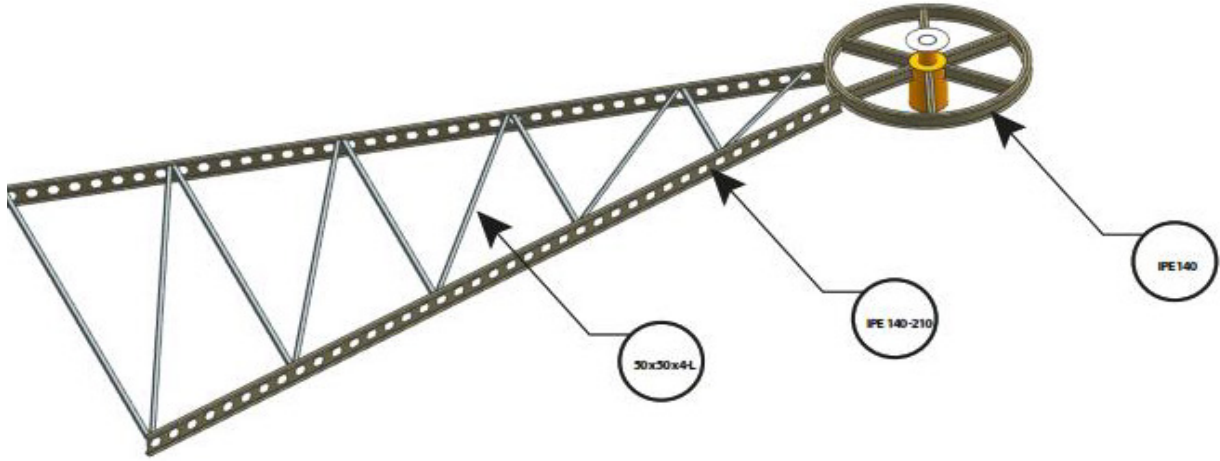

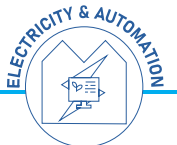
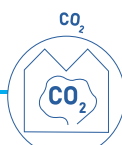
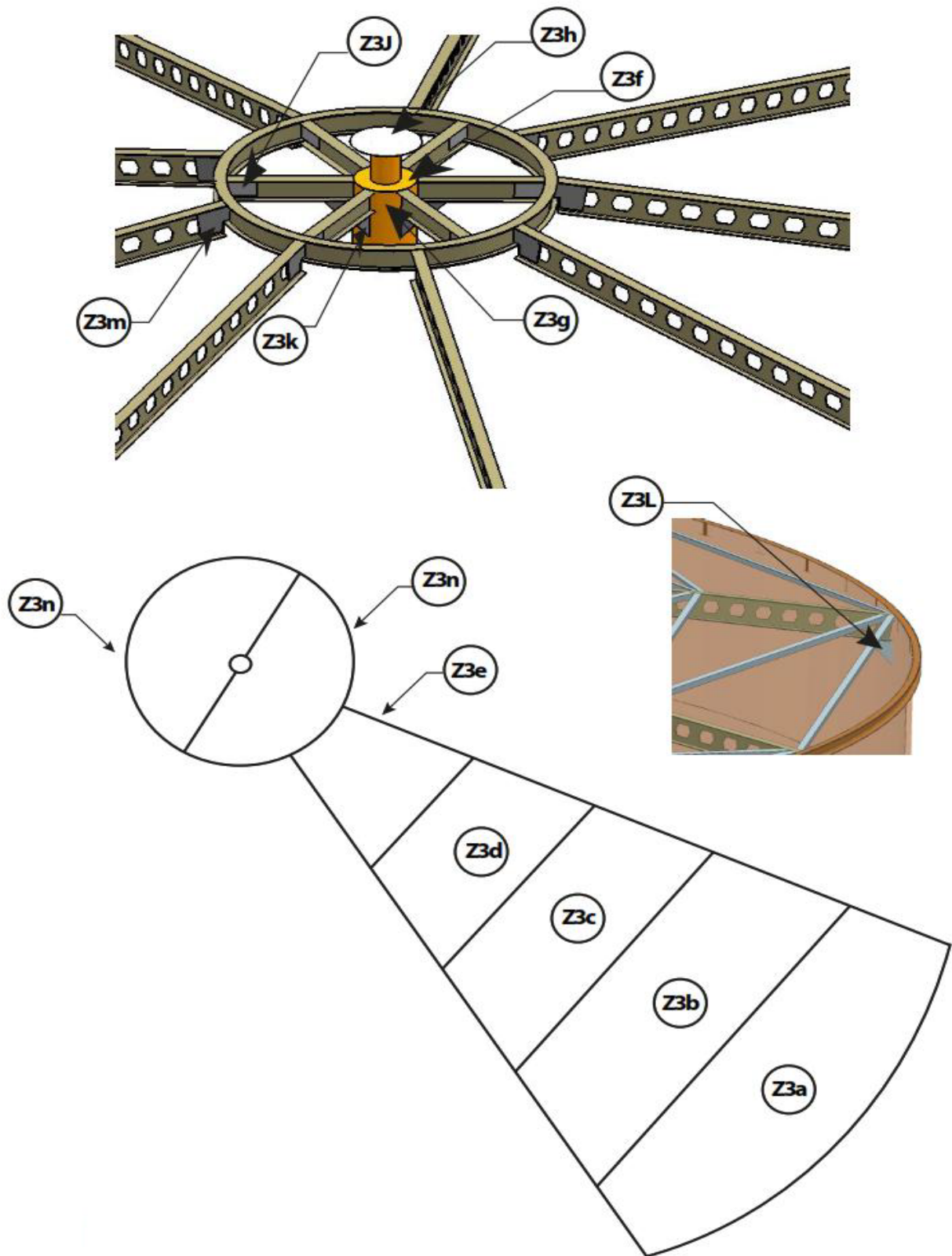

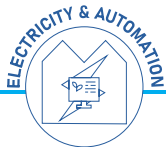
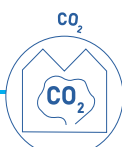
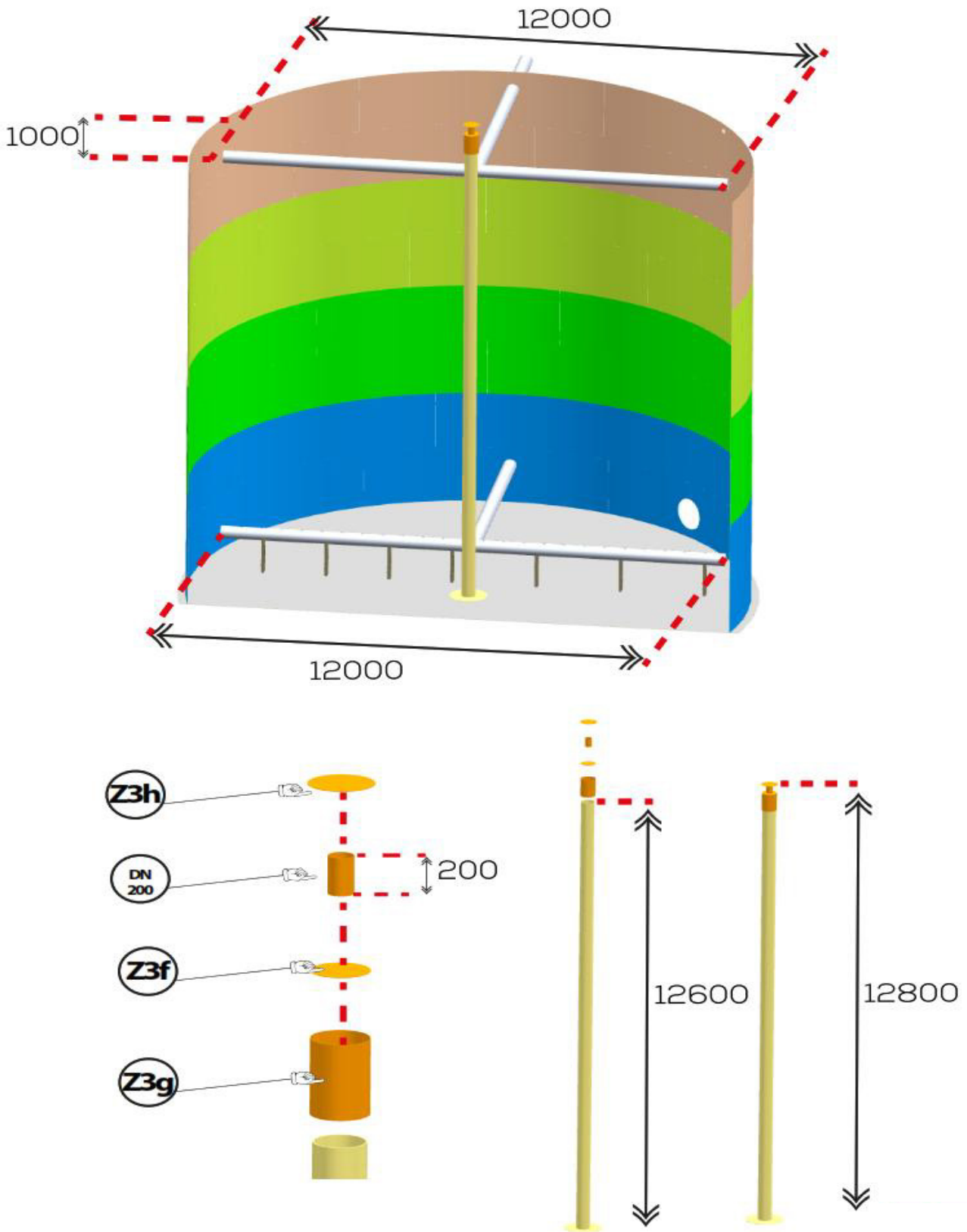

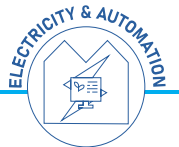
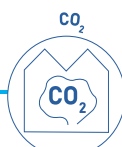
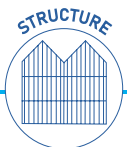
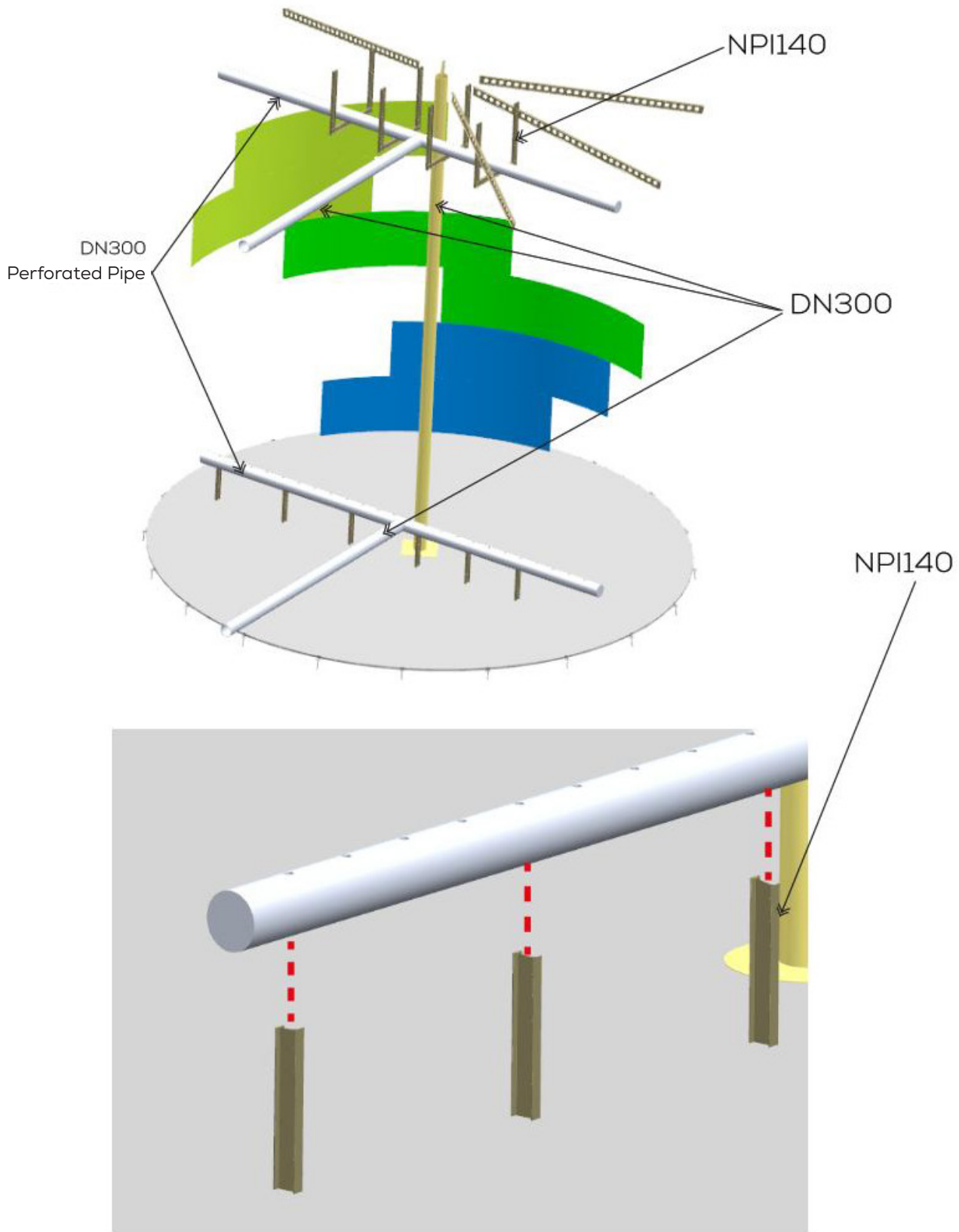

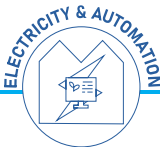
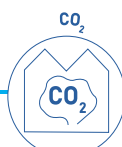
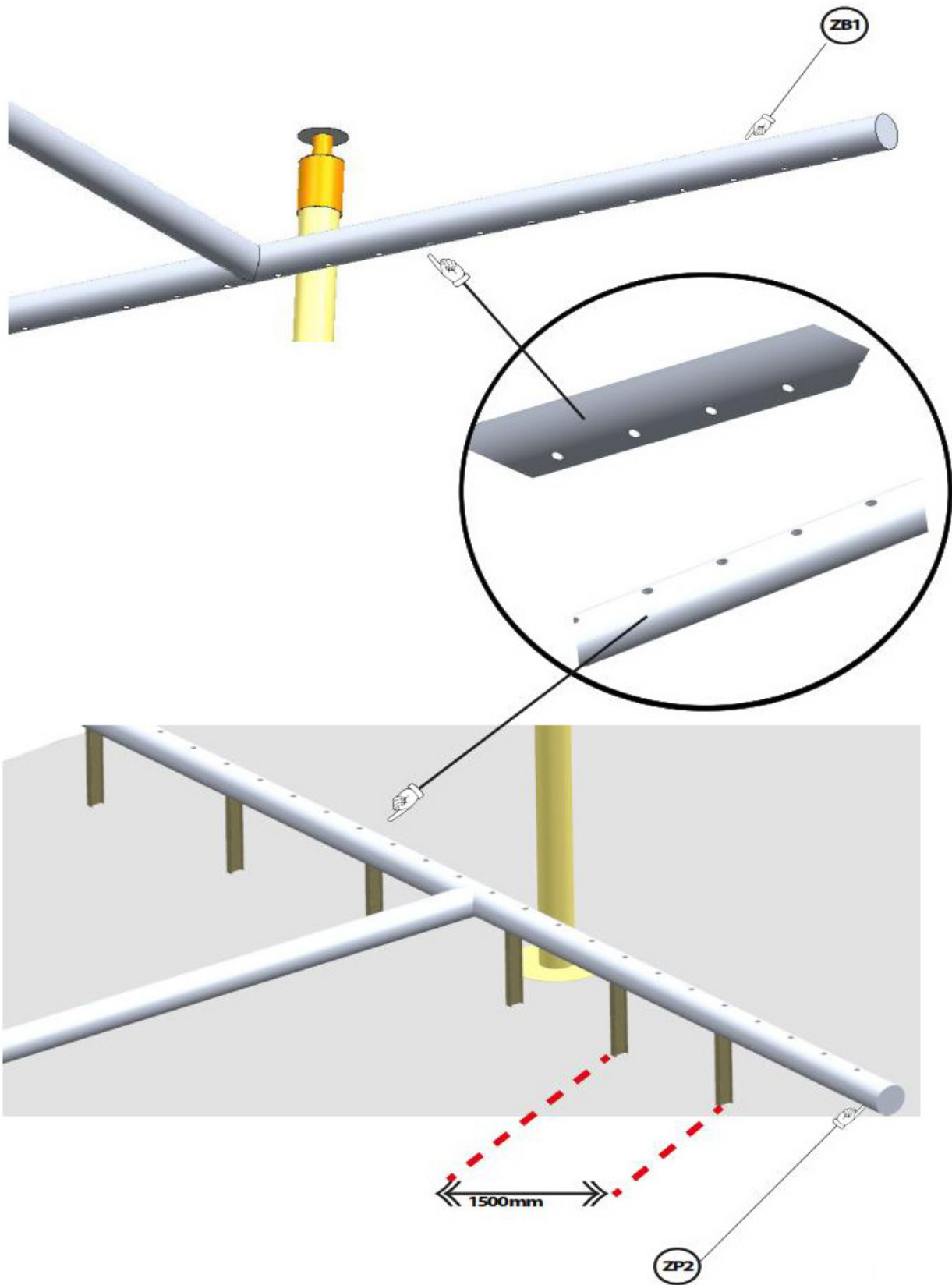

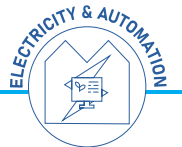
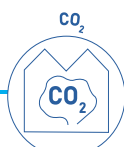
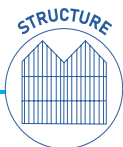
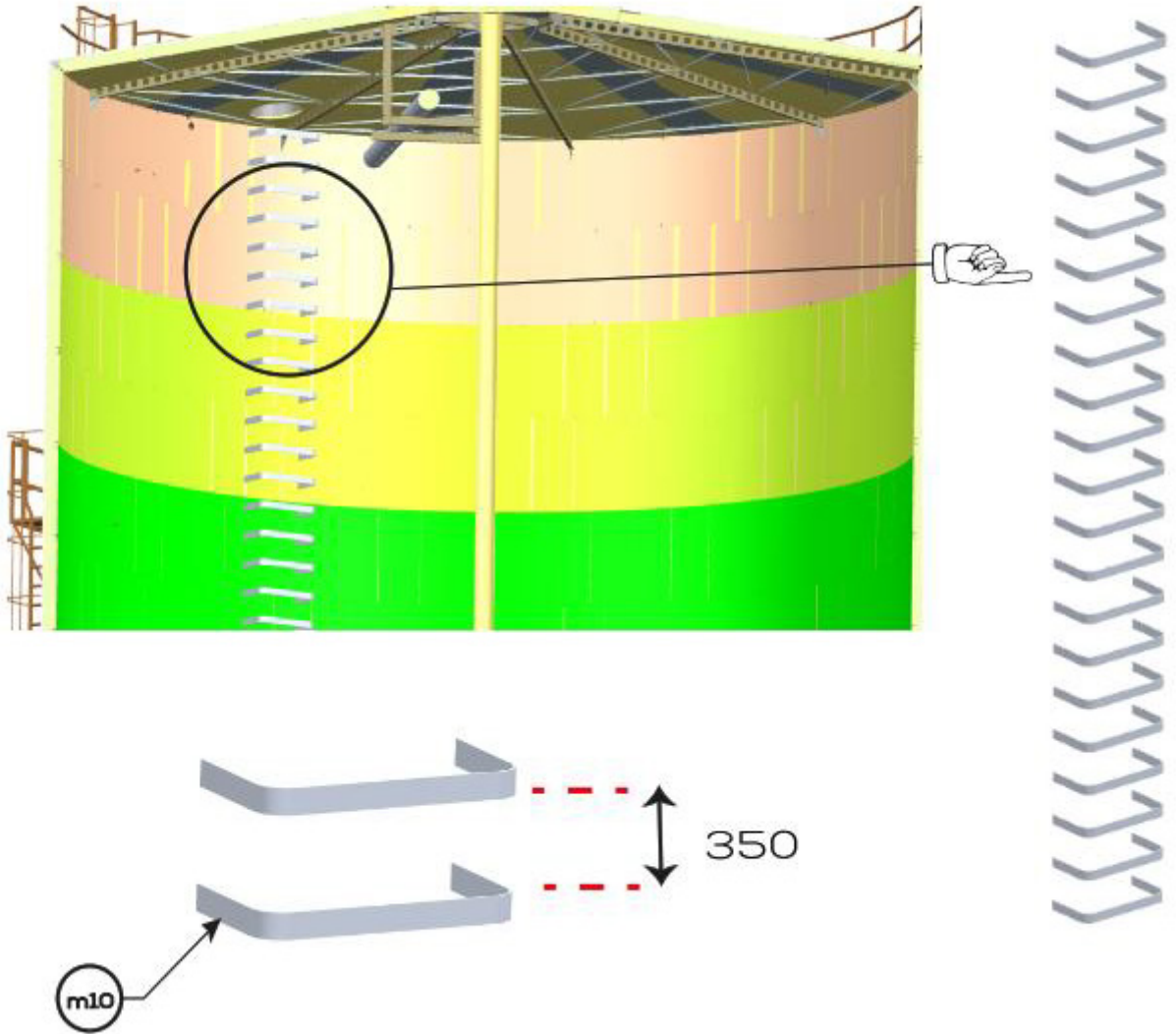

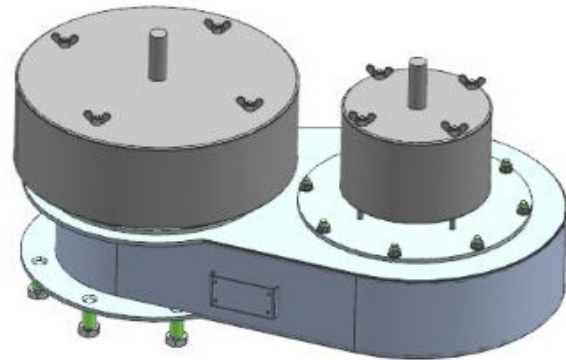
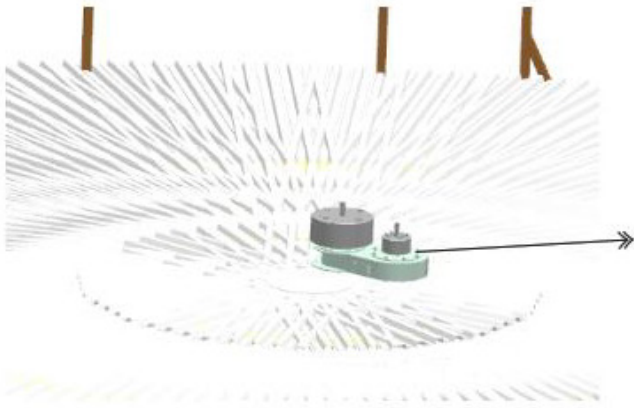

## Prescon PV-200

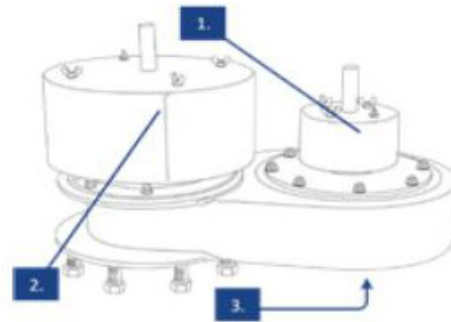
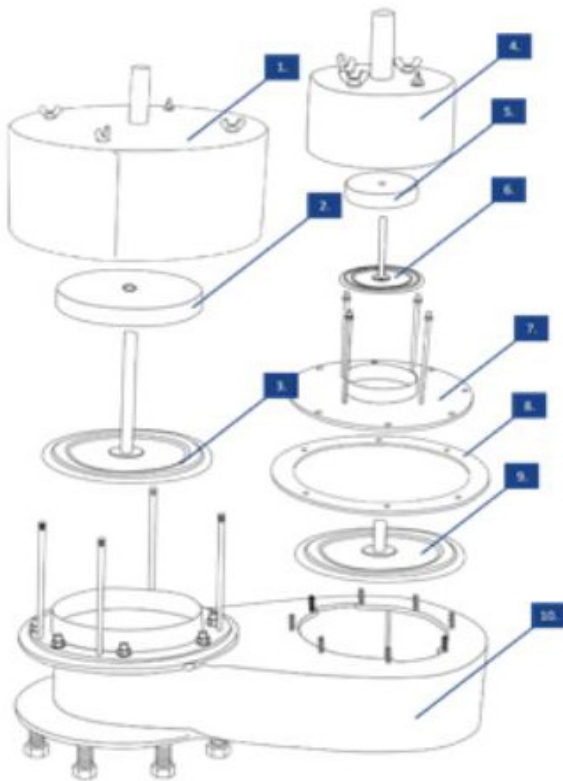

### Diagram Components

1. Pressure relief cap
2. Weight
3. Valve
4. Operating pressure cap
5. Operating pressure weight
6. Operating pressure valve
7. Cap plate
8. Silicone gasket
9. Vacuum valve
10. Safety valve body

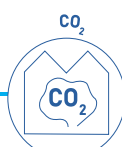

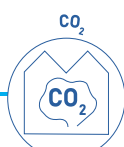
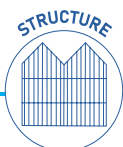
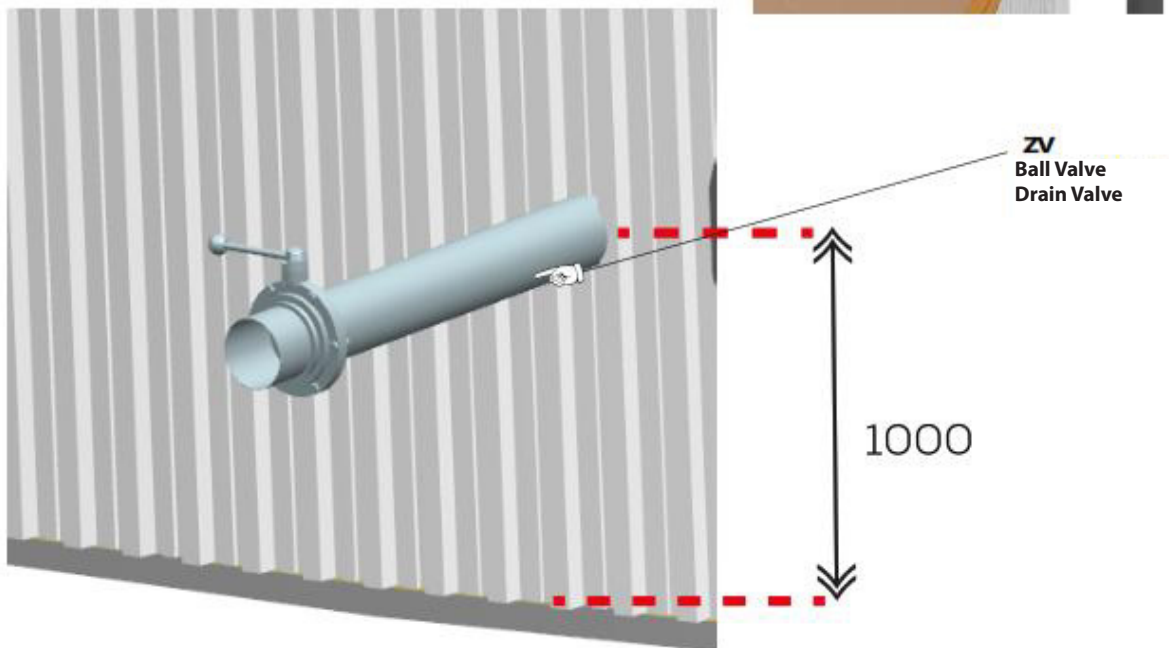
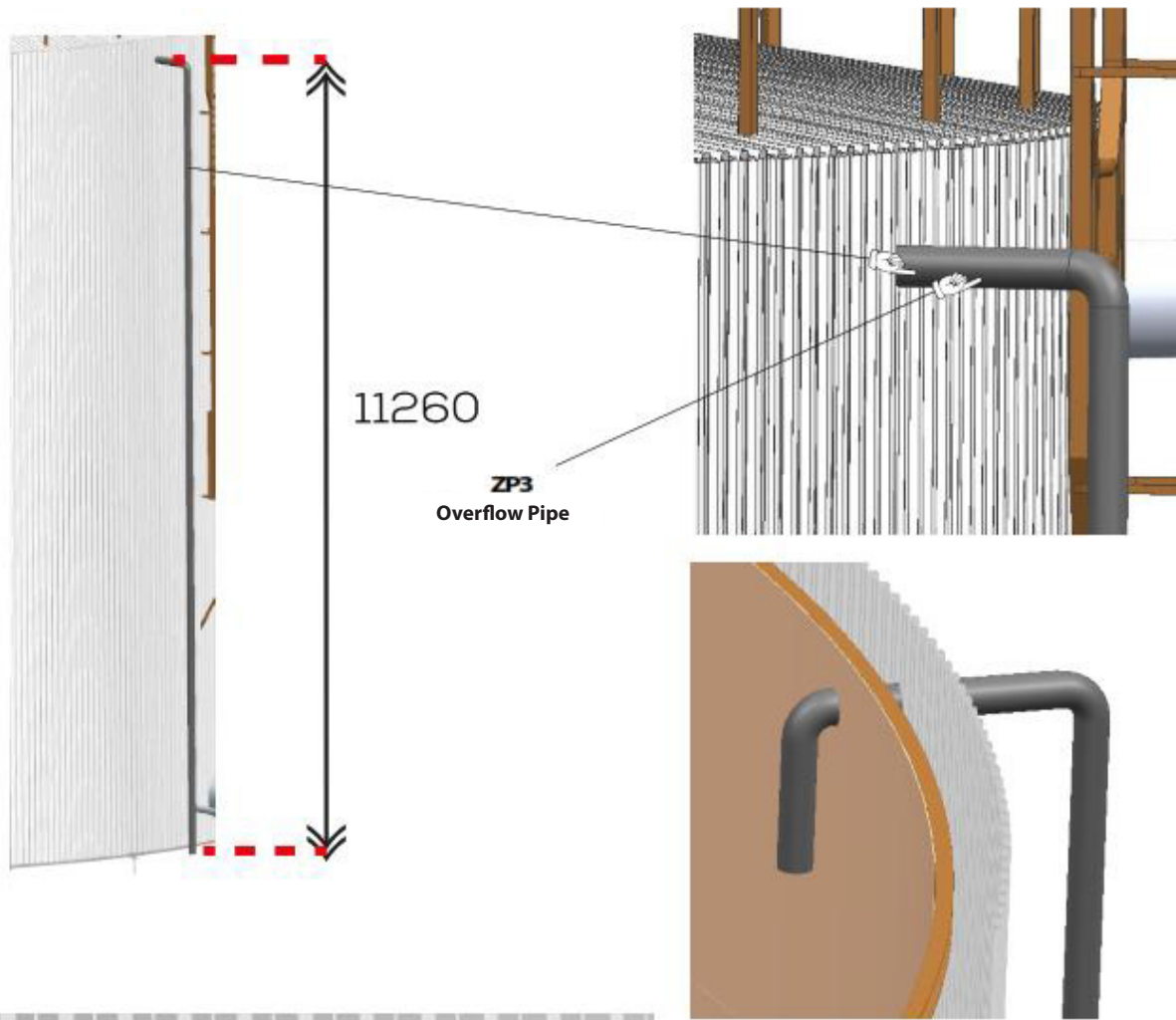

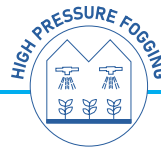
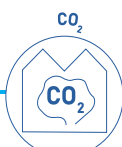
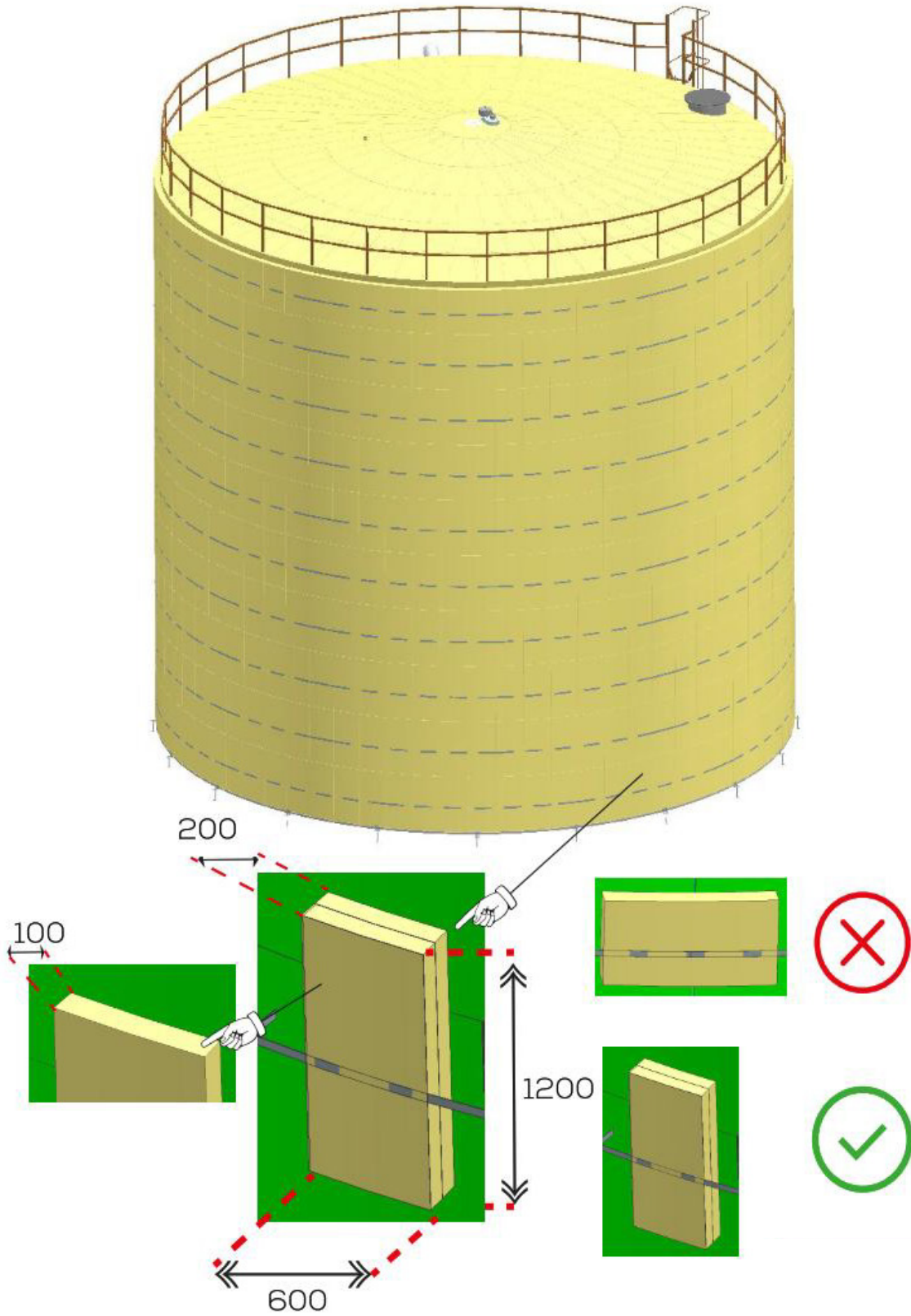

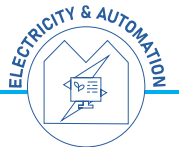
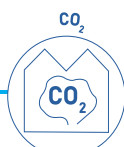
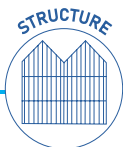
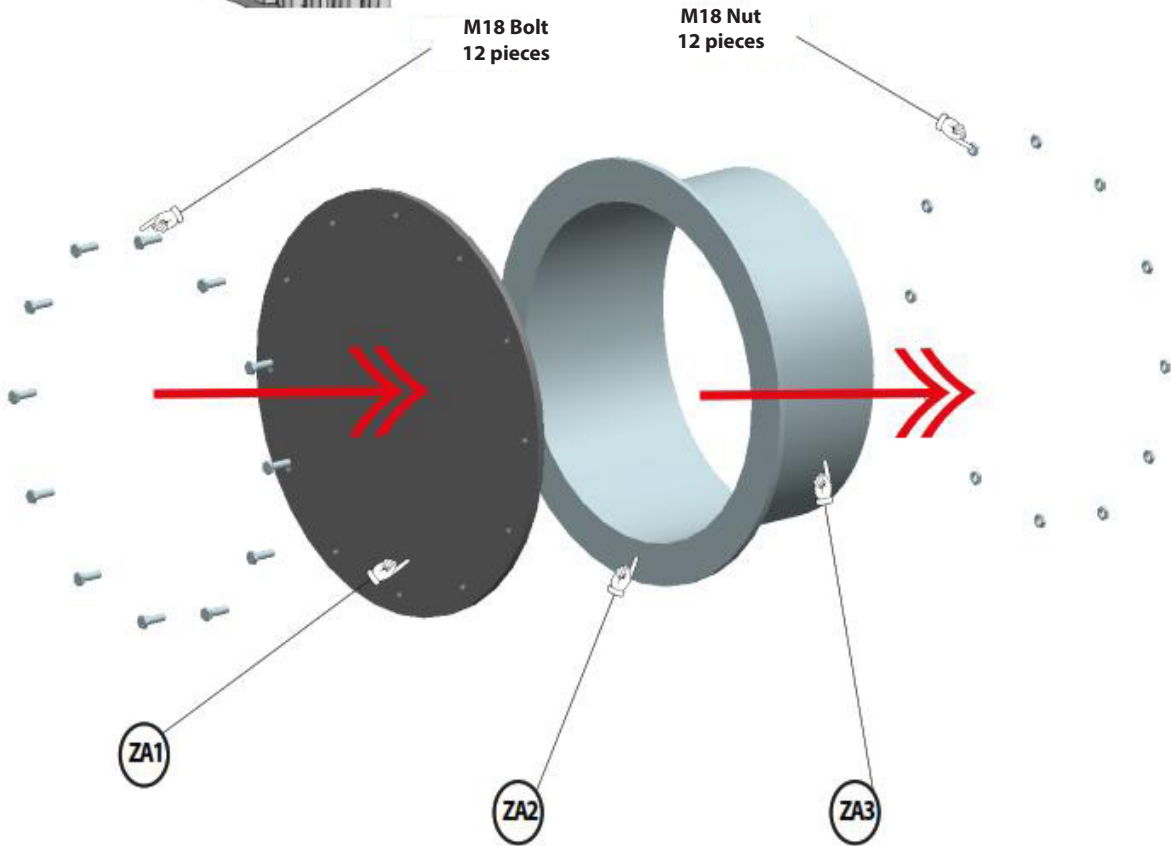
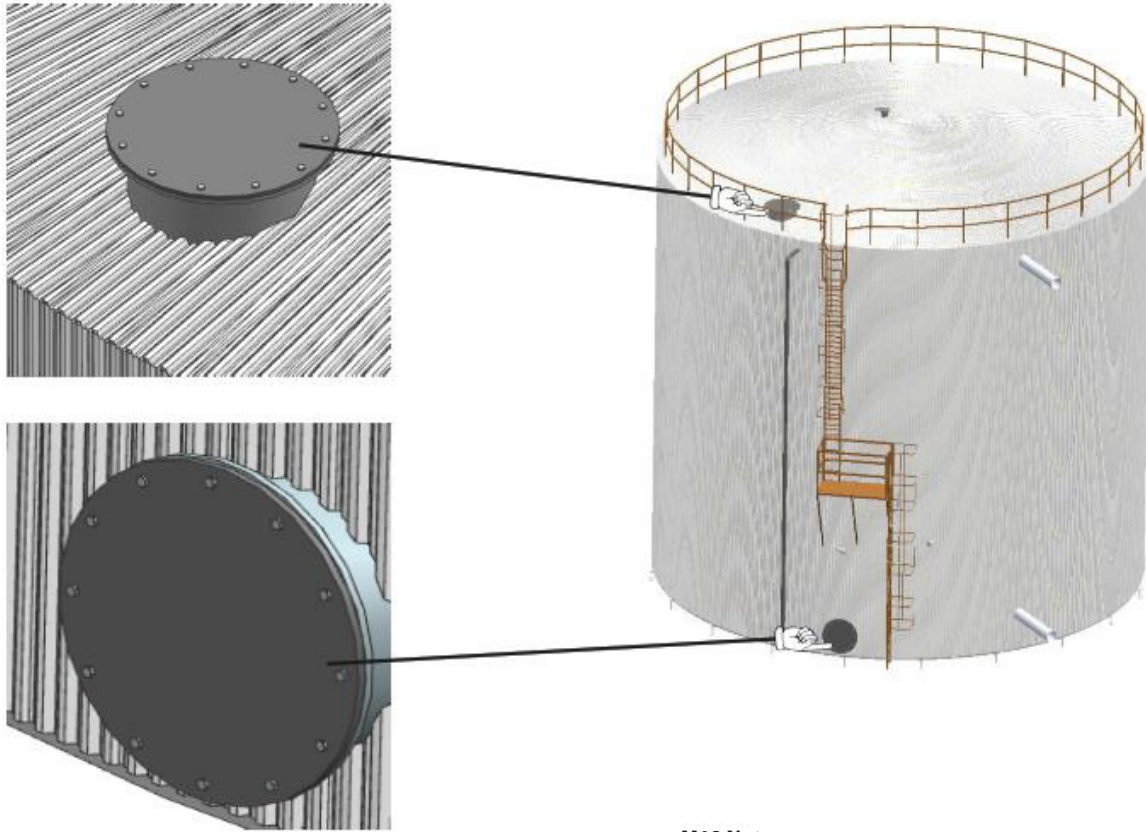

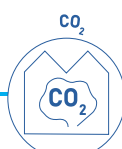
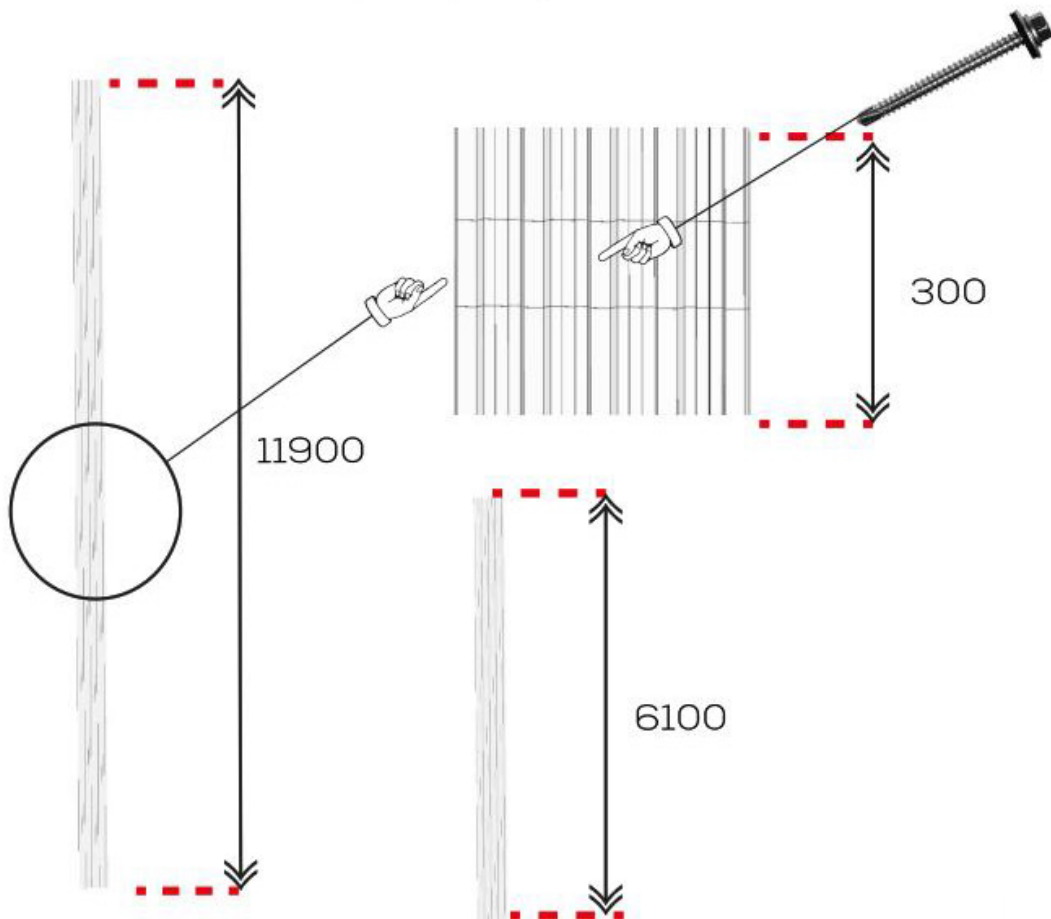

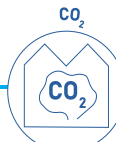
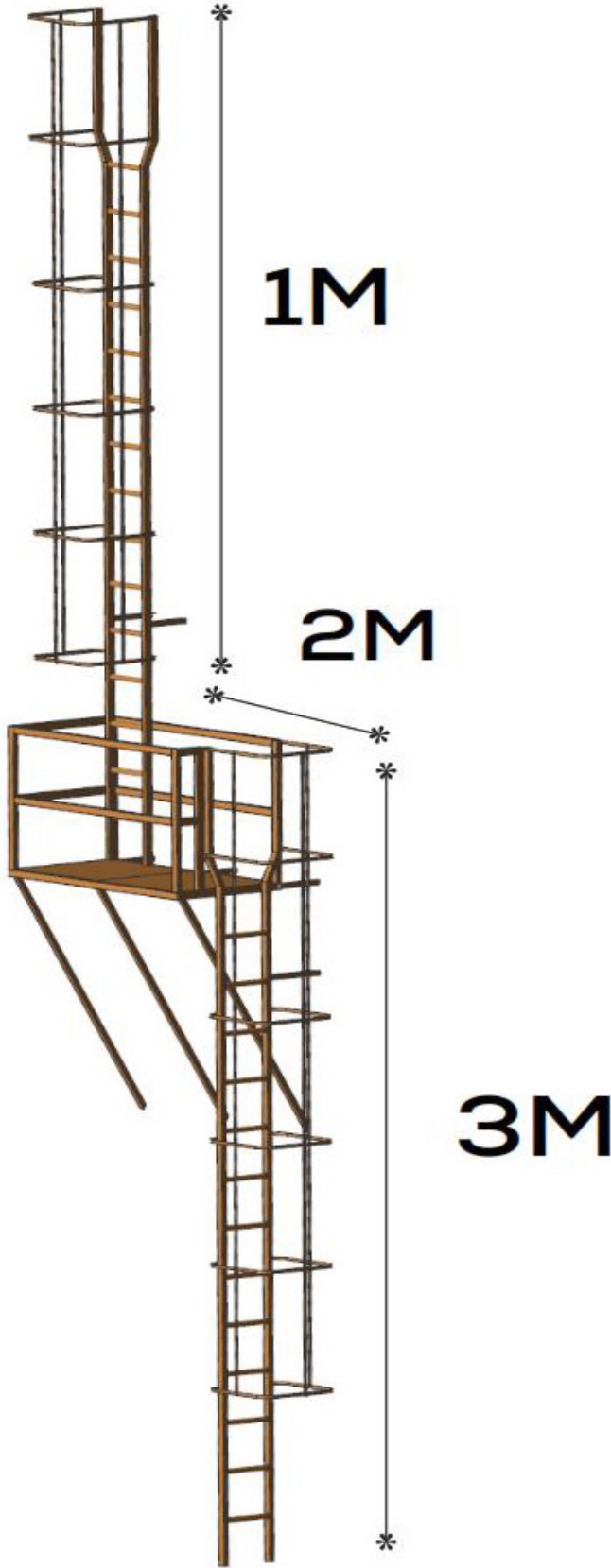

1M

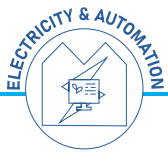
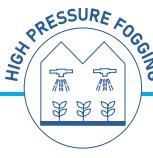
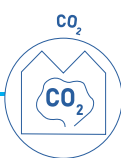
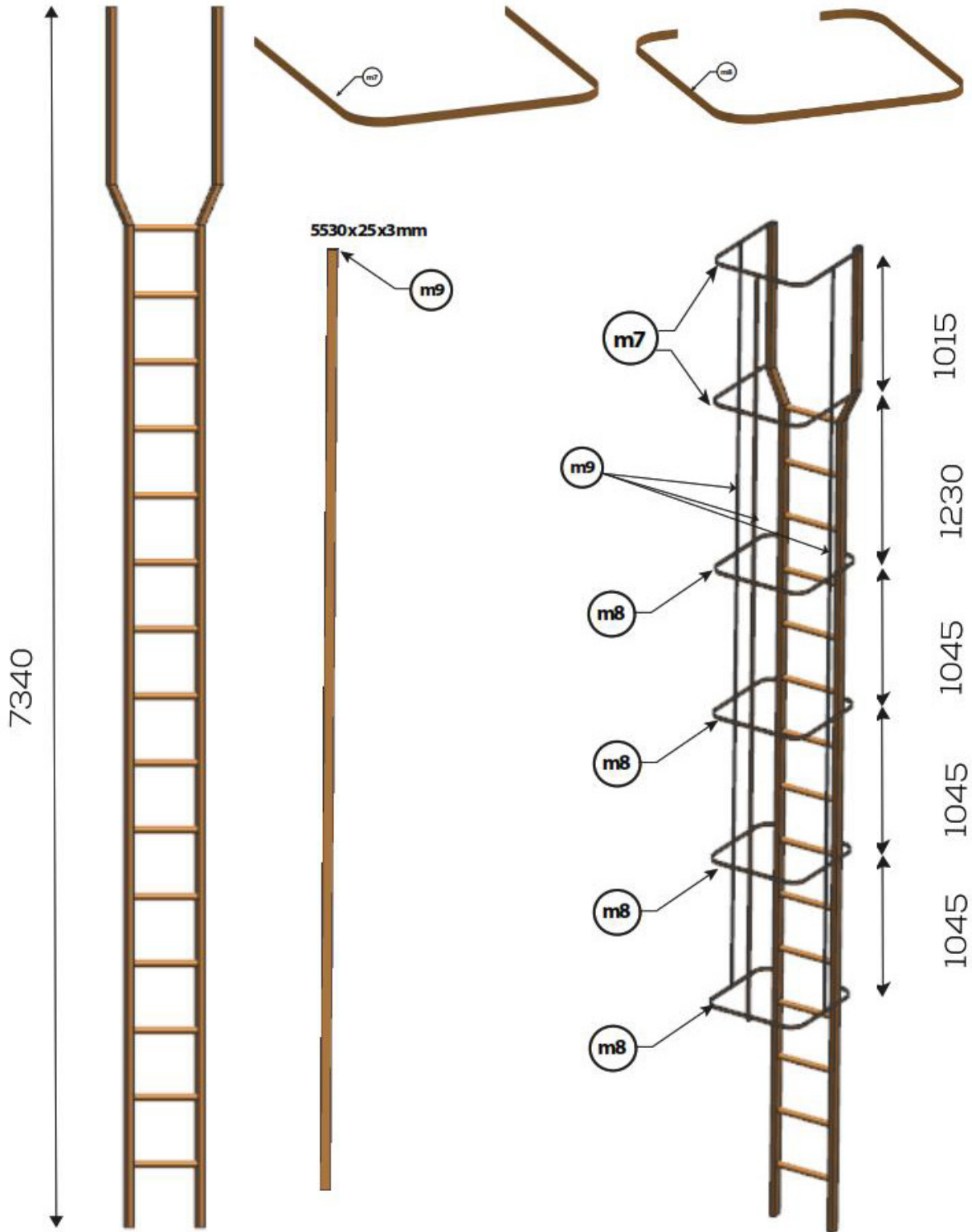

2M

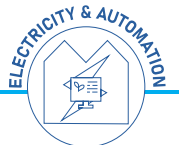
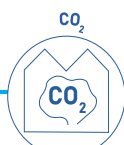
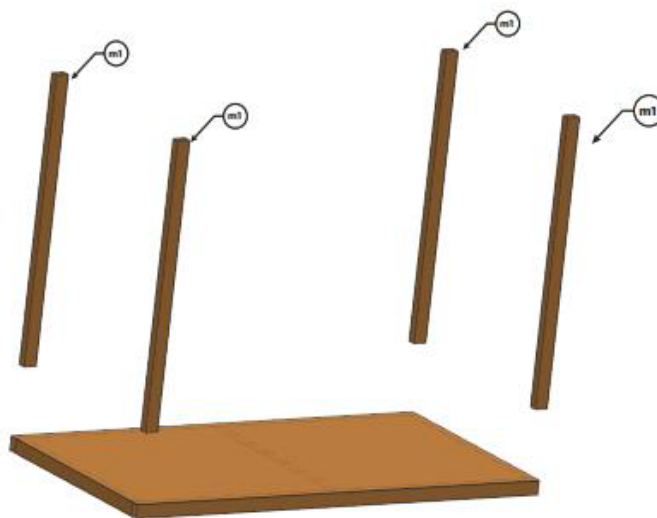
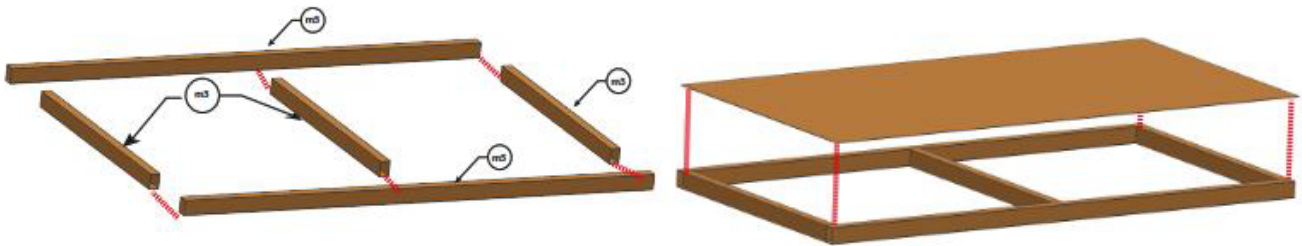
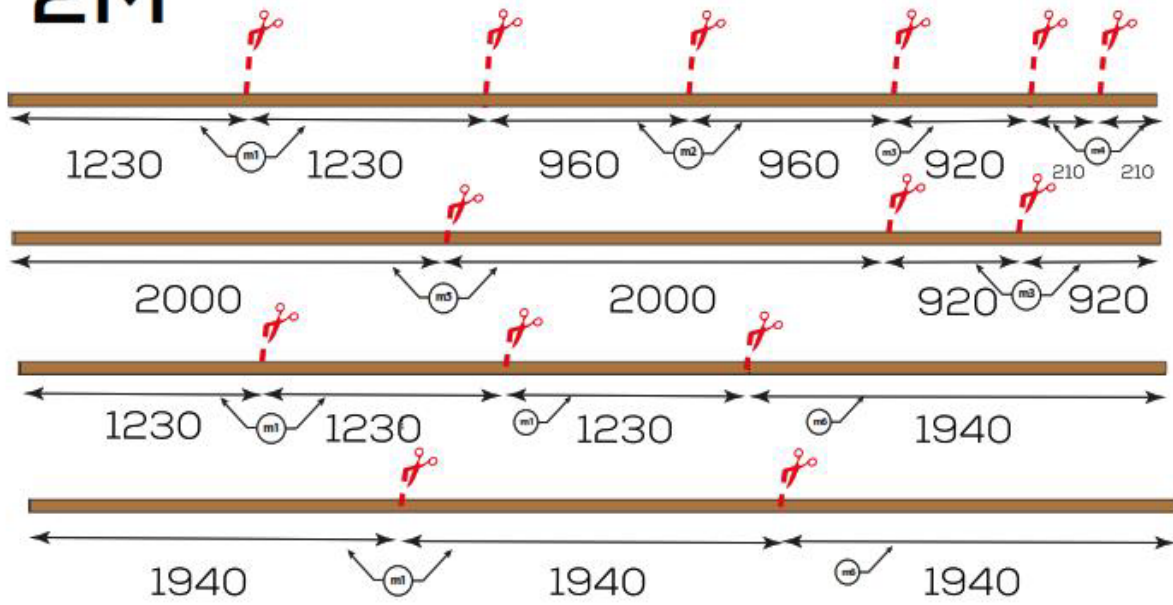

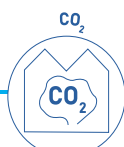
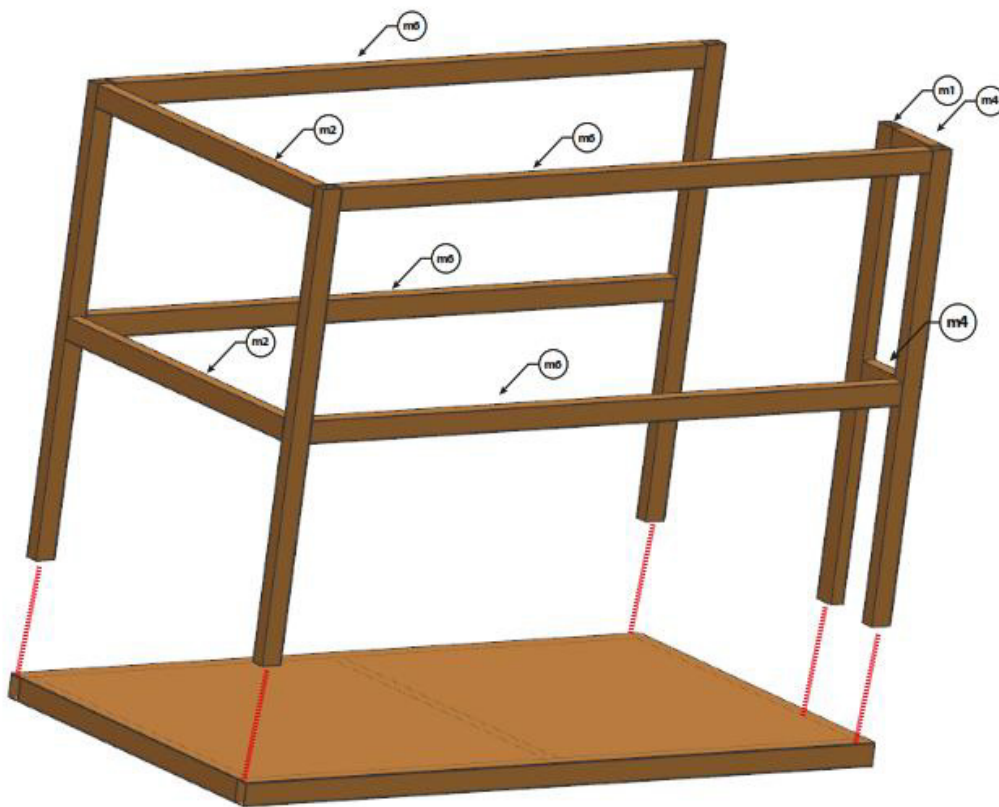

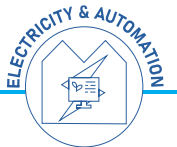
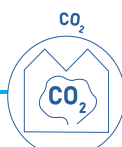
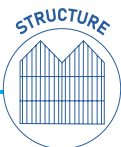
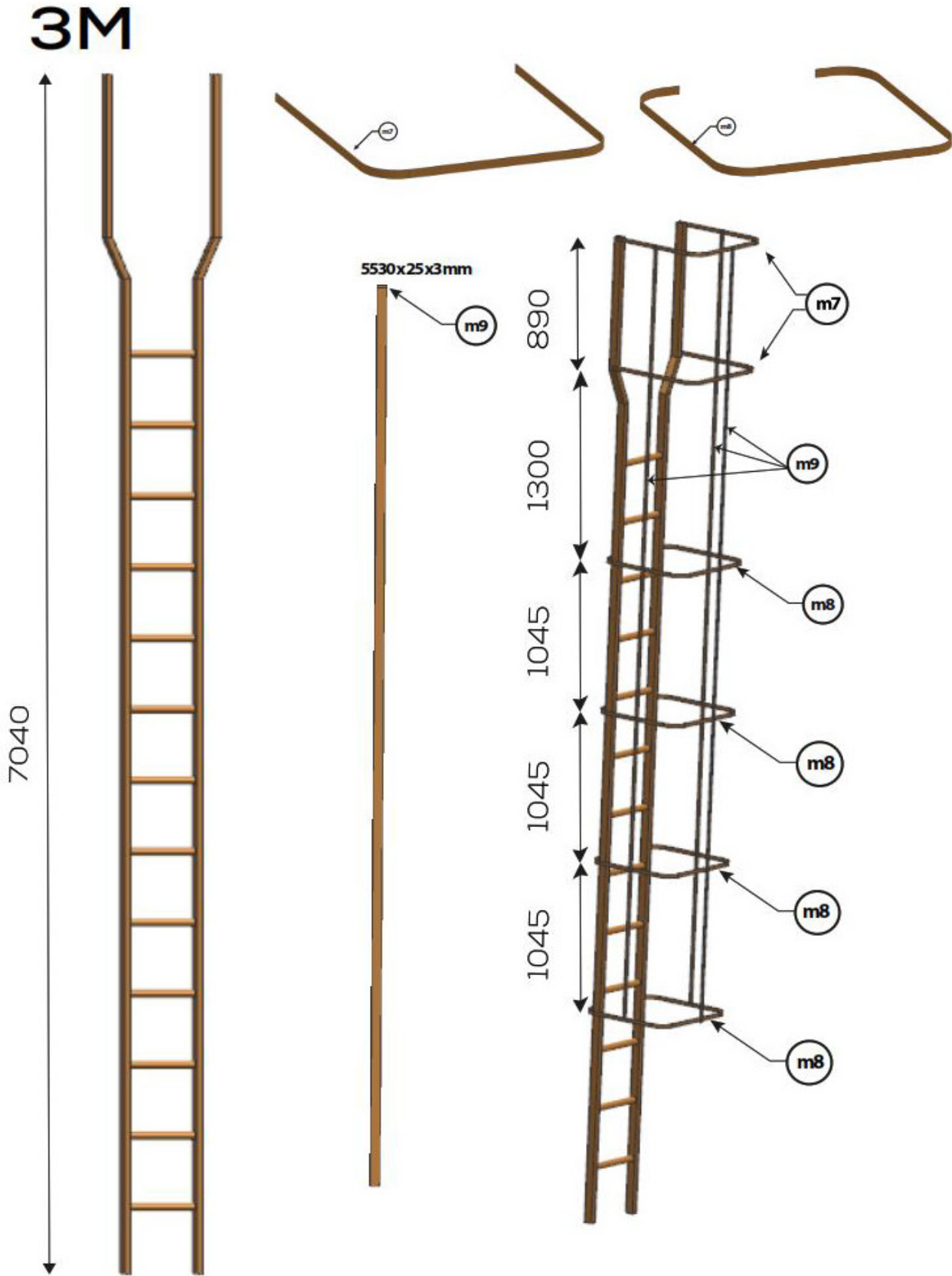

**Çerkeşli Osb Mah. İmes 7.Cadde  
No:3 Dilovası/Kocaeli**

**+90 262 244 44 94**