

timfog



BUFFER TANK

Instrucciones de instalación

BUFFER TANK

Instrucciones de instalación

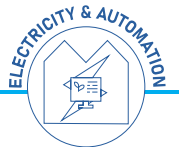
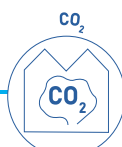
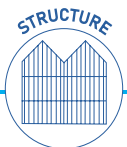

BUFFER TANK

CN	安装说明
CRO	Upute za ugradnju
CZ	Návod k instalaci
DK	Montagevejledning
E	Instrucciones de montaje
F	Instructions de montage
GB	Installation instructions
GR	Οδηγία συναρμολόγησης
H	Szerelési utasítás
I	Istruzioni di montaggio
NL	Montagehandleiding
P	Instrução de montagem
S	Monteringsanvisningz
SER	Uputstvo za montažu
SF	Asennusohje
SK	Návod na montáž
SLO	Navodila za montažo
TR	Montaj talimatı
PL	Instrukcja montazu
NO	Installasjonsanvisning
RU	Указания по установке
ROM	Instrucțiuni de montare

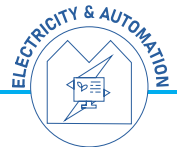
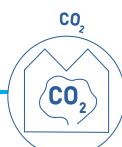



2500 TONELADAS

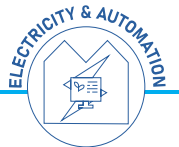
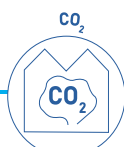
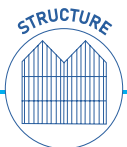

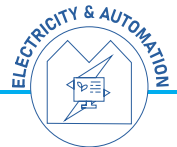
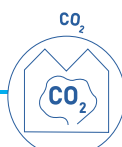
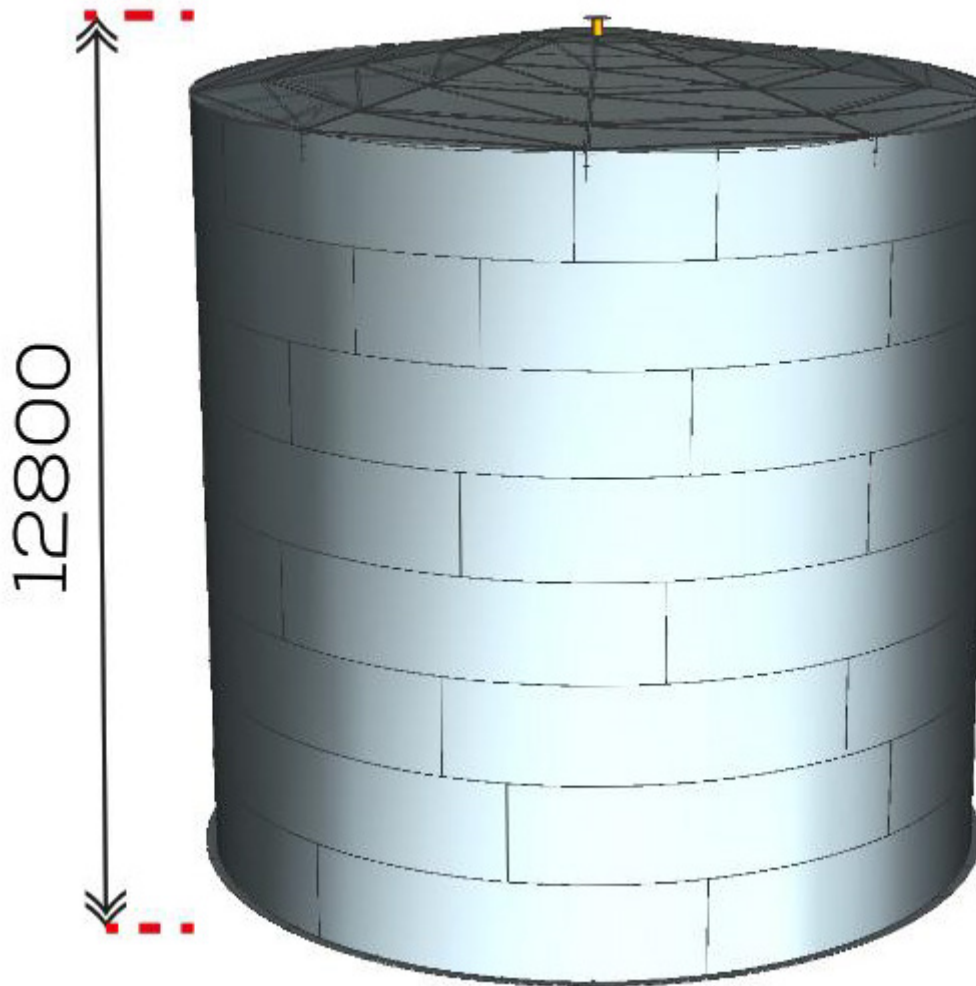

2500 TONELADAS



1. CAMIÓN



2. CAMIÓN



3. CAMIÓN



4. CAMIÓN

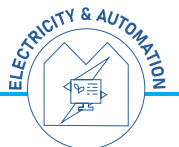
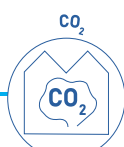
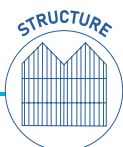
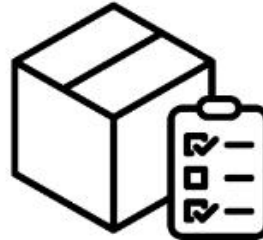

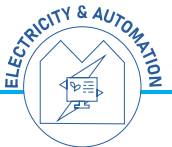
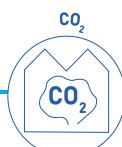
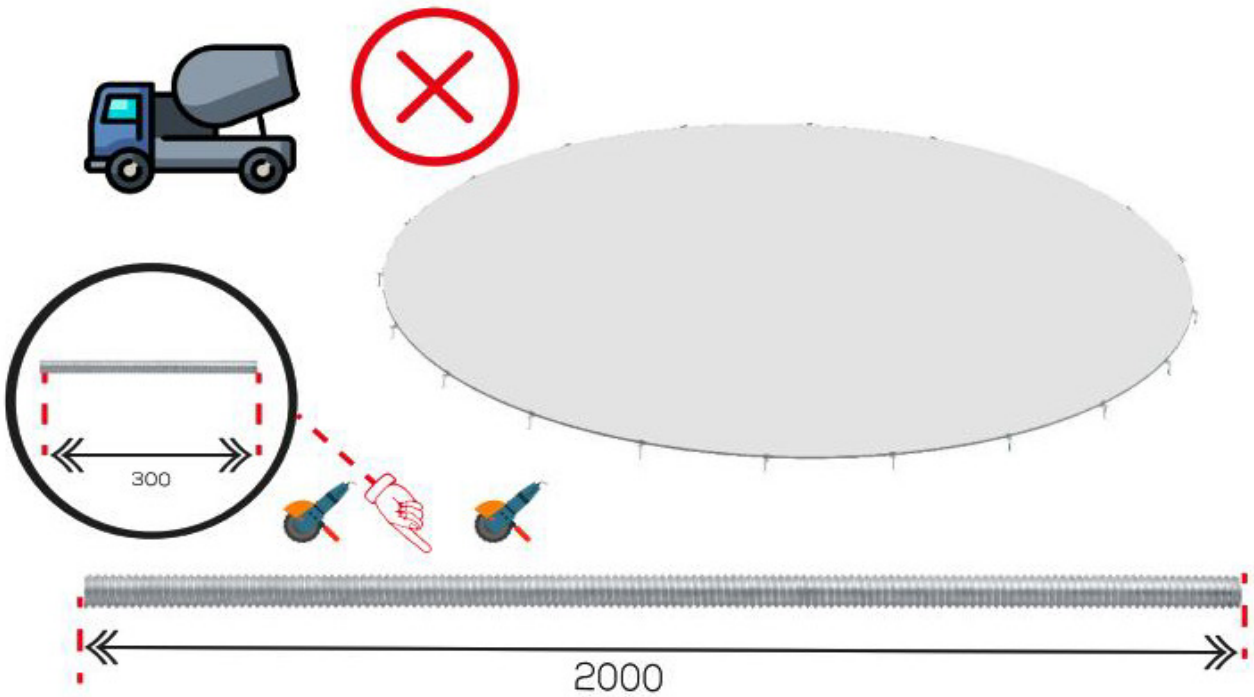
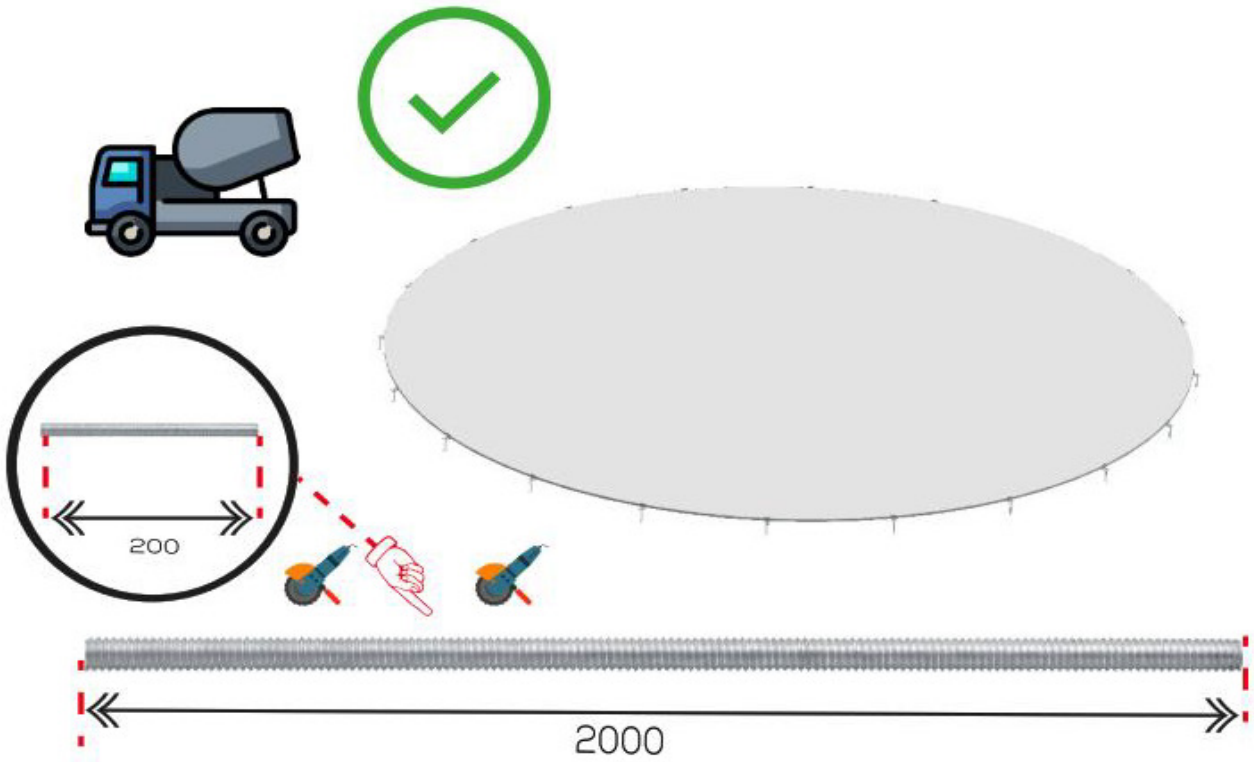

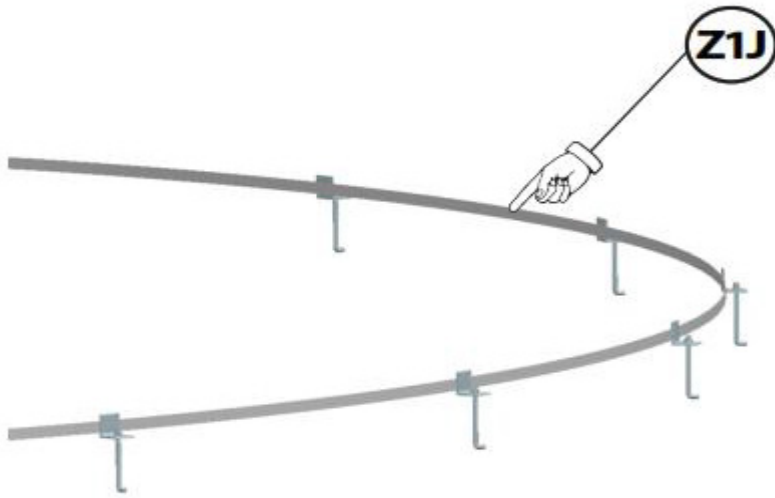
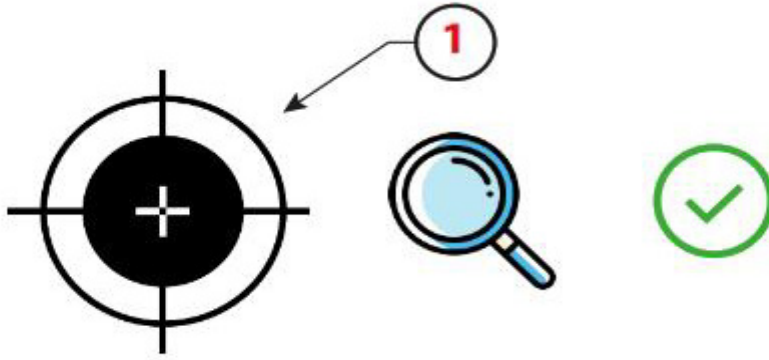

Aislamiento XPS y arena aceitosa

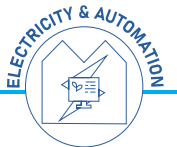
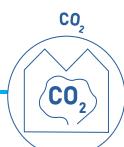
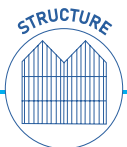
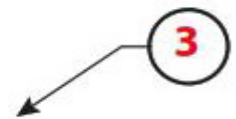
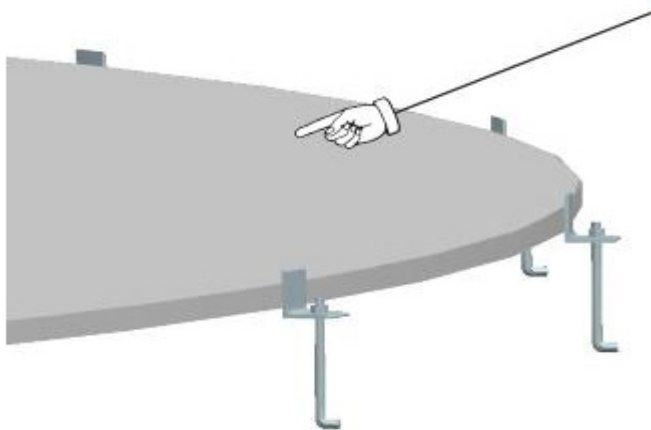

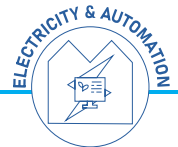
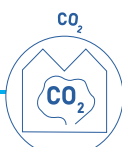
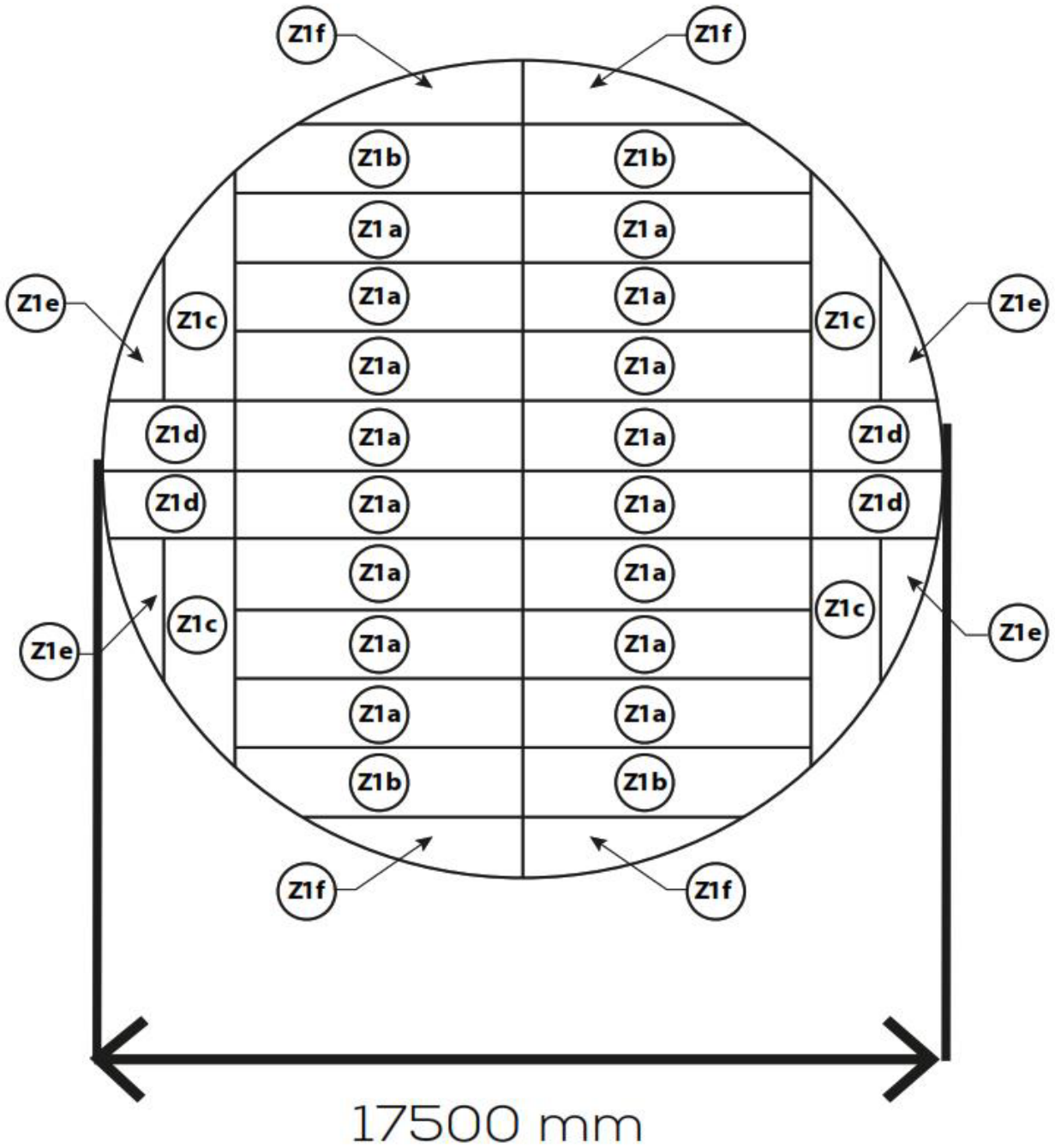

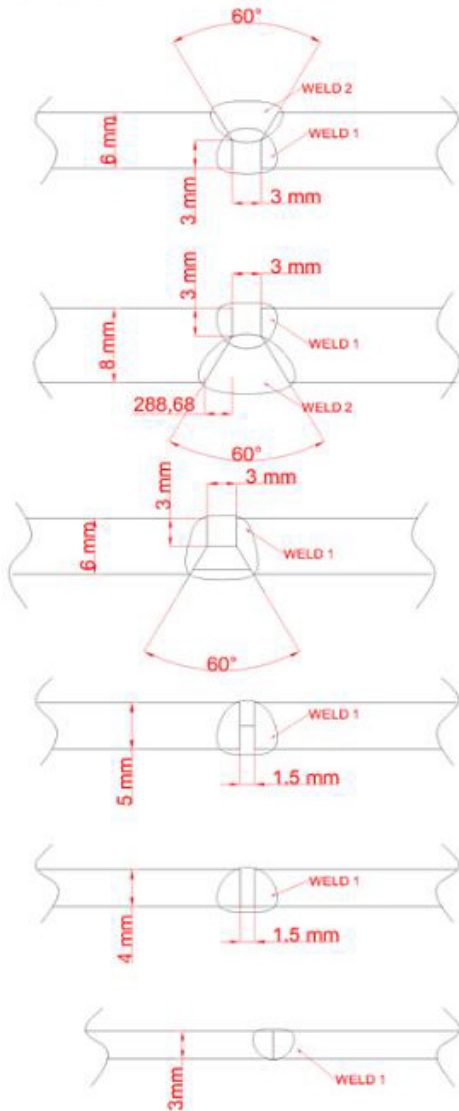
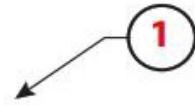

Soldadura de las placas inferiores

Tipo de ranura: Parte superior
 Soldadura:
 Soldadura 1 = 4 mm – 130A
 Soldadura 2 = 5 mm – 170A
 Velocidad de soldadura: 5 m/h

Soldadura de las placas de pared (exterior)

Dirección de soldadura: De abajo hacia arriba
 Soldadura:
 Soldadura 1 = 4 mm – 130A
 Soldadura 2 = 4 mm – 180A
 Velocidad de soldadura: 3 m/h

Soldadura de las placas de pared (exterior)

Dirección de soldadura: De abajo hacia arriba
 Soldadura:
 Soldadura 1 = 3.25 mm – 110A
 Velocidad de soldadura: 4.6 m/h

Soldadura de las placas de pared (sin ranura)

Dirección de soldadura: De abajo hacia arriba
 Soldadura:
 Soldadura 1 = 3.25 mm – 110A
 Velocidad de soldadura: 6 m/h

Soldadura de las placas de pared (sin ranura)

Dirección de soldadura: De abajo hacia arriba
 Soldadura:
 Soldadura 1 = 4 mm – 120A
 Velocidad de soldadura: 20 m/h

Soldadura de las placas superiores

Tipo de ranura: Ninguna
 Dirección de soldadura: Soldadura 1 = 4 mm – 115A
 Velocidad de soldadura: 27 m/h

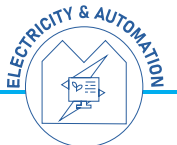
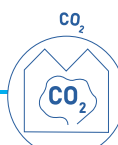
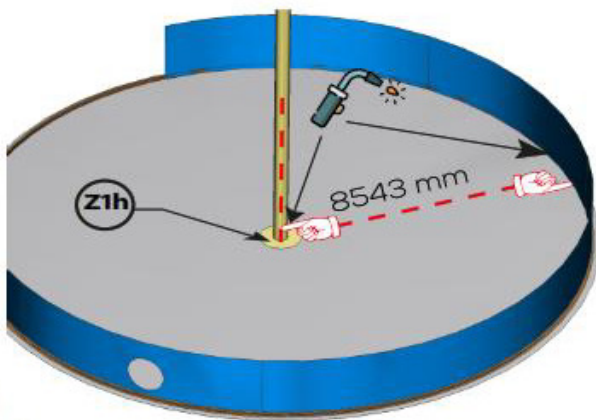
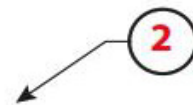

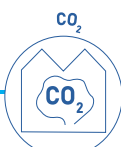
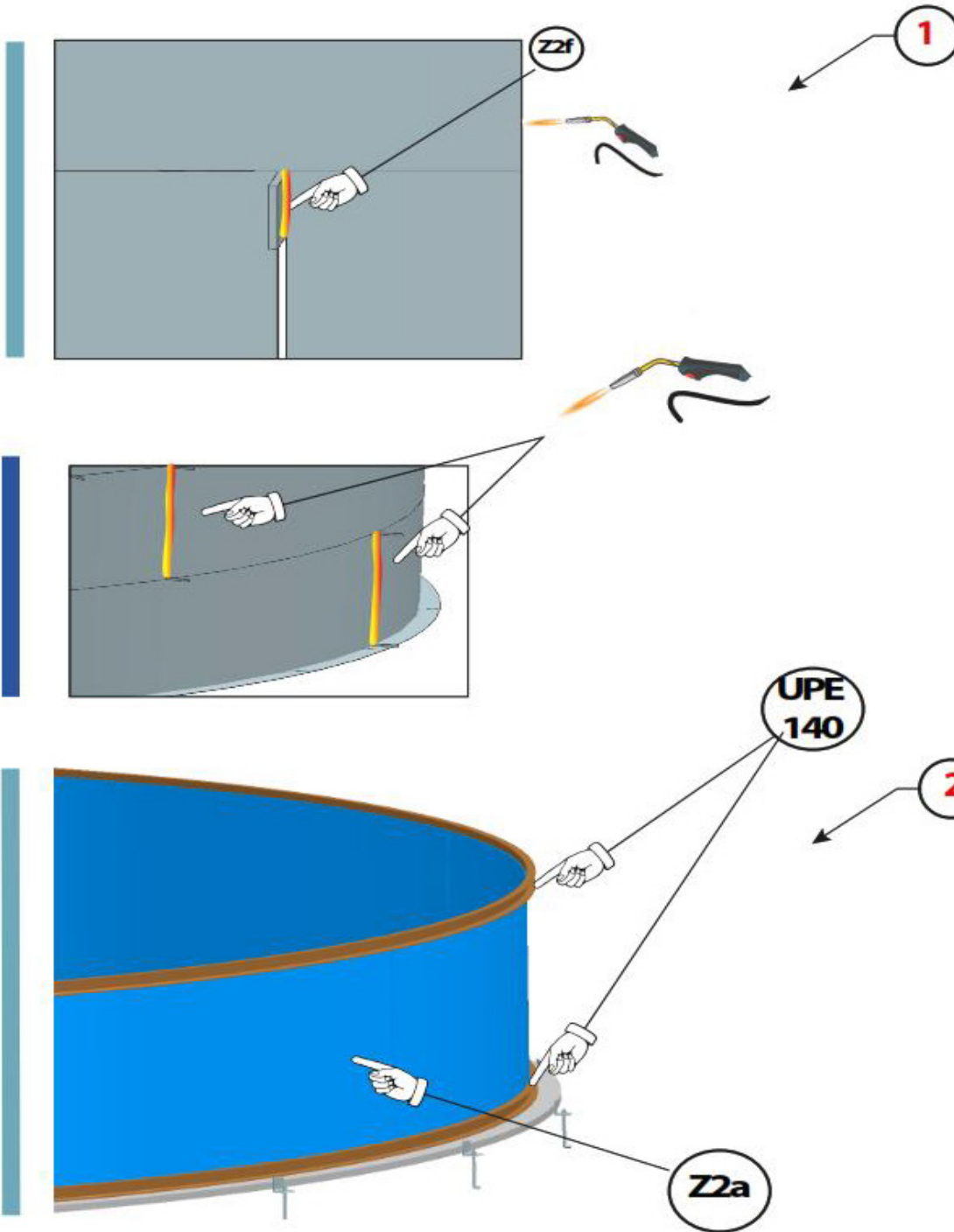

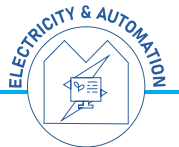
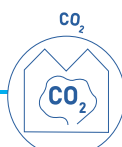
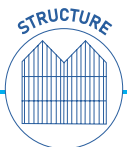
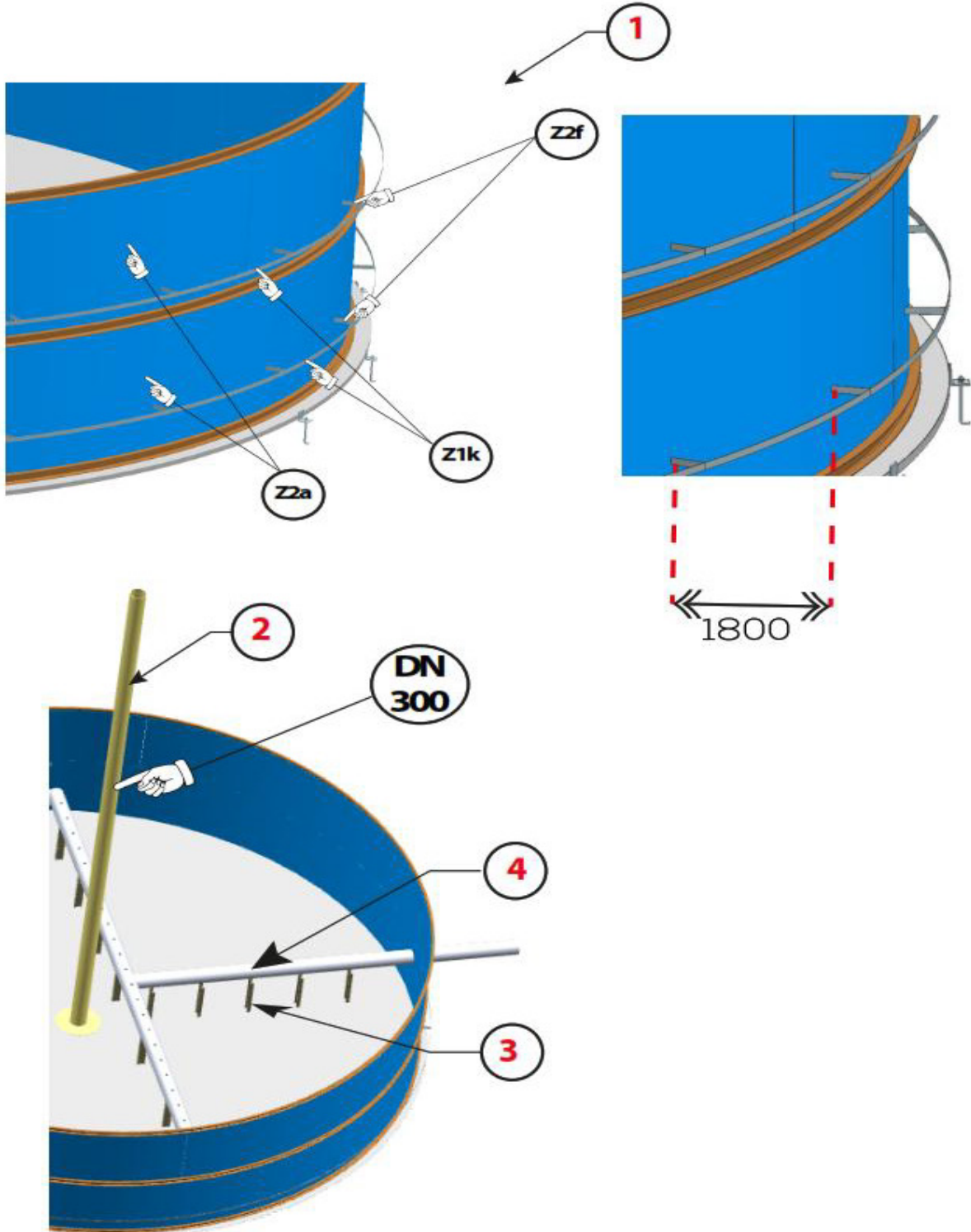

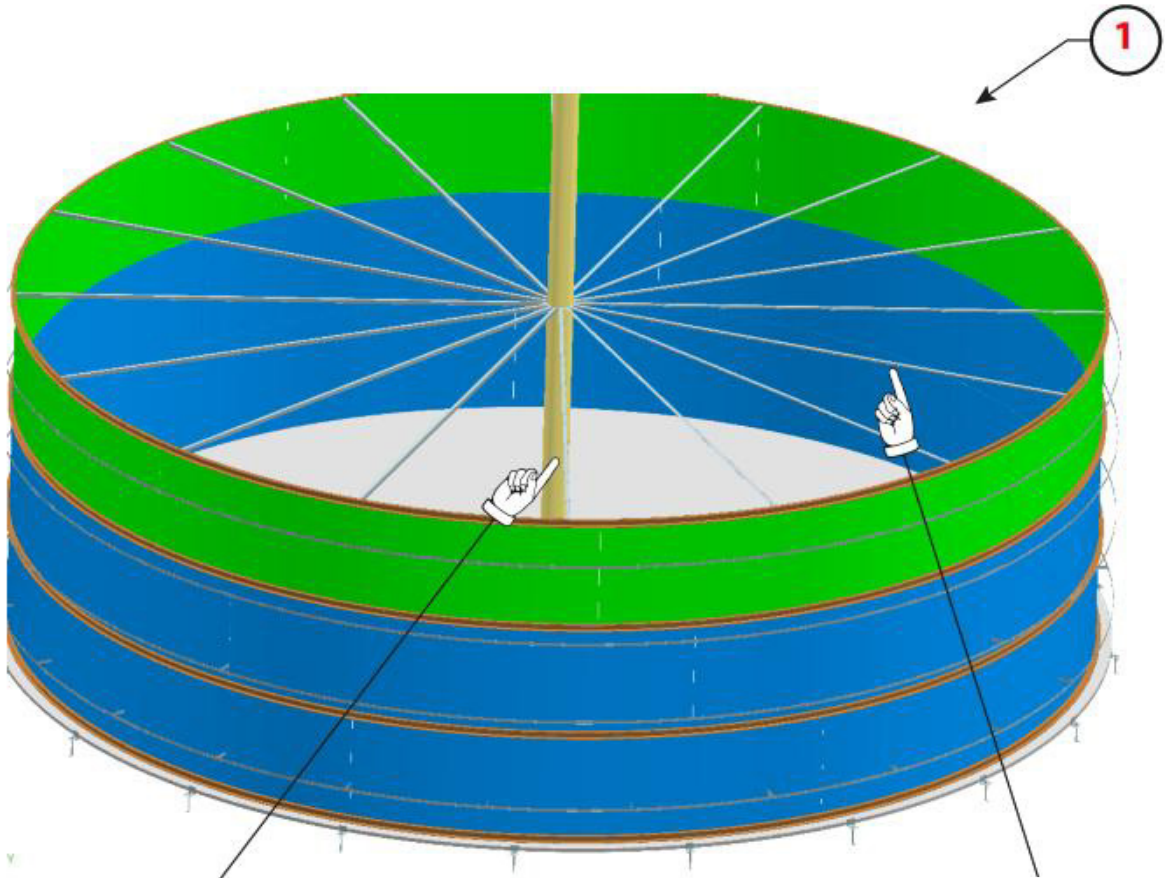

Z2b

P1
Perfil en L 50 x 50
16 piezas

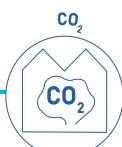

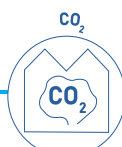
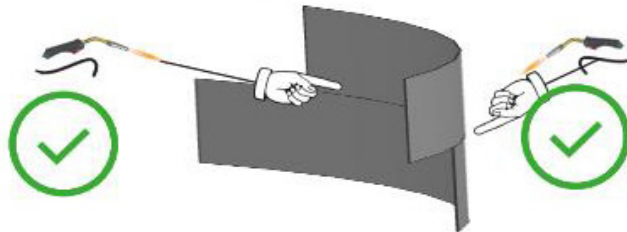
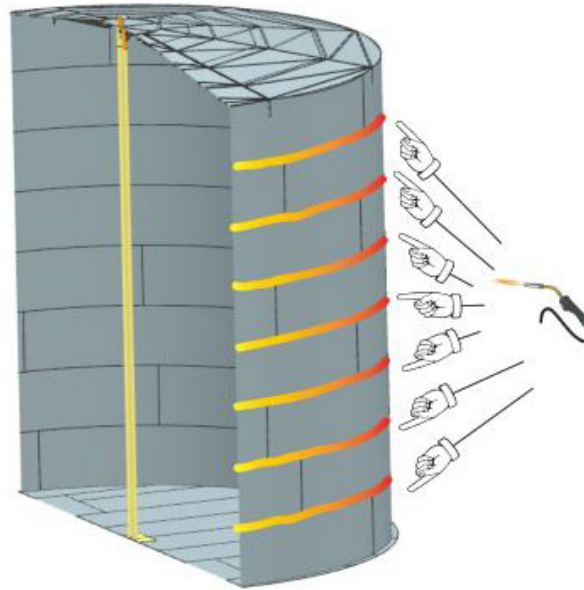
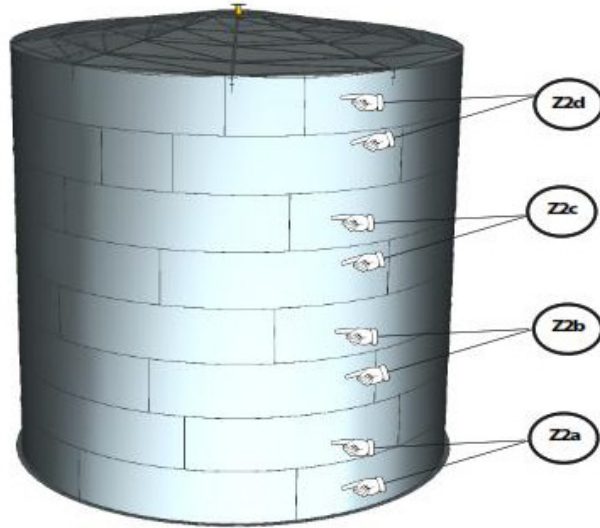

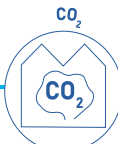
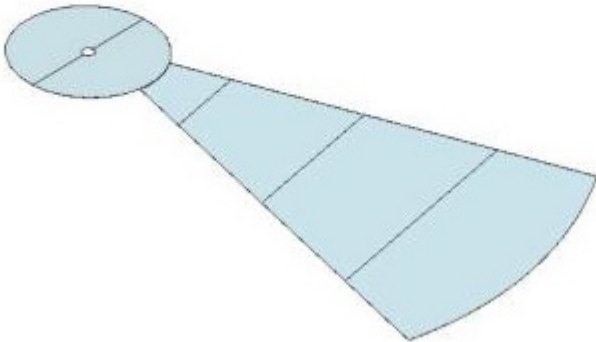
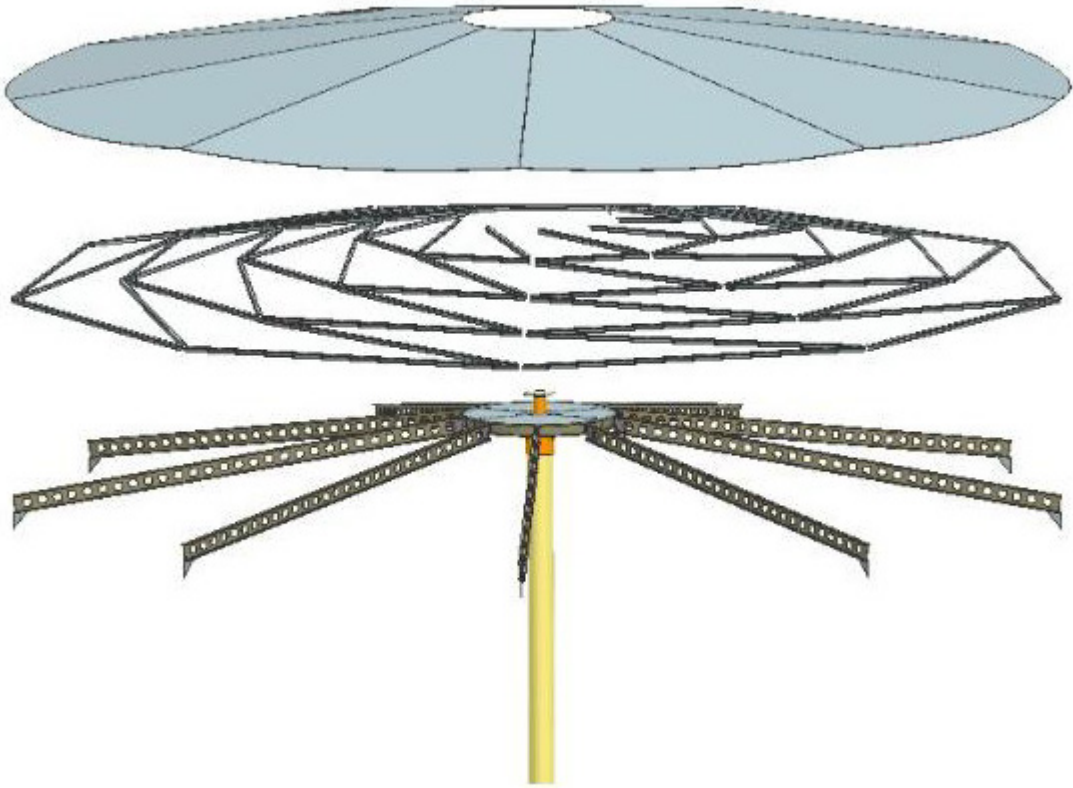

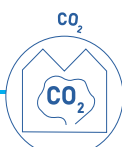
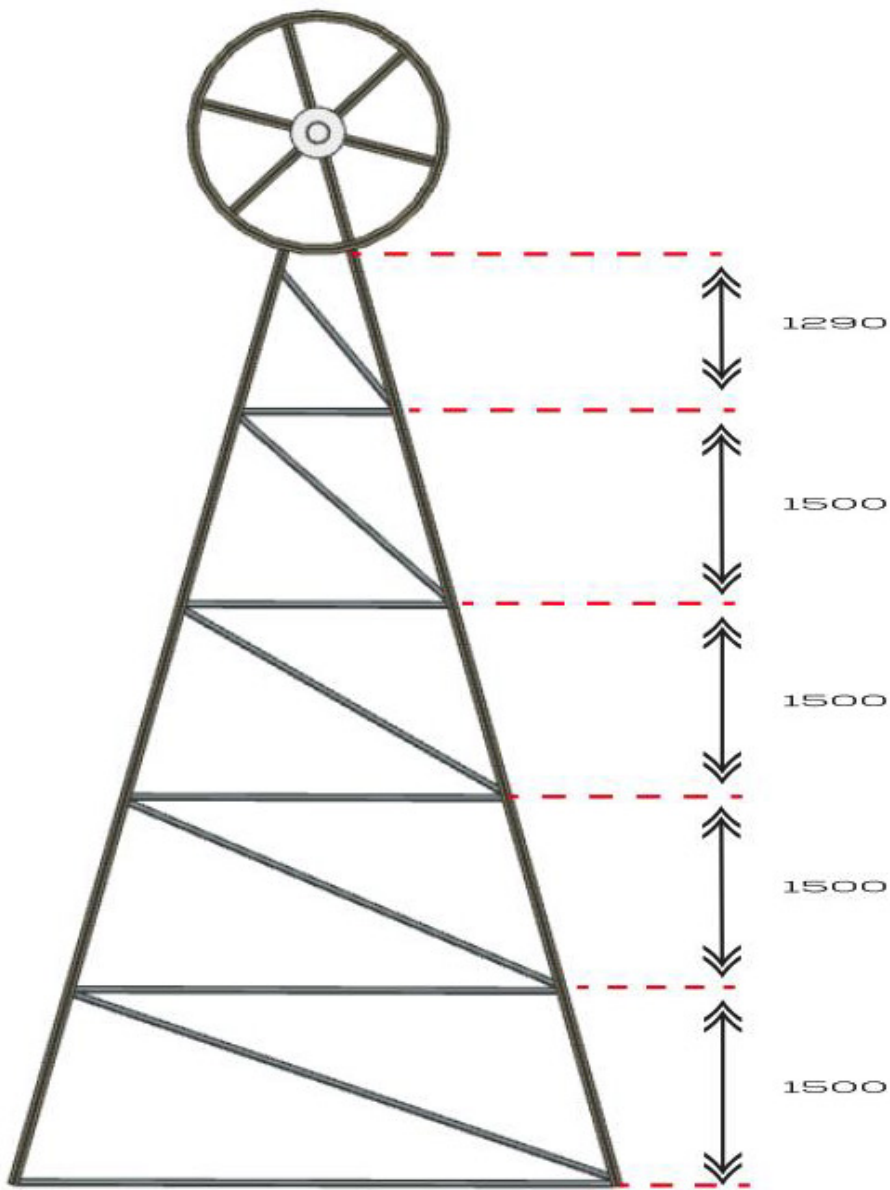
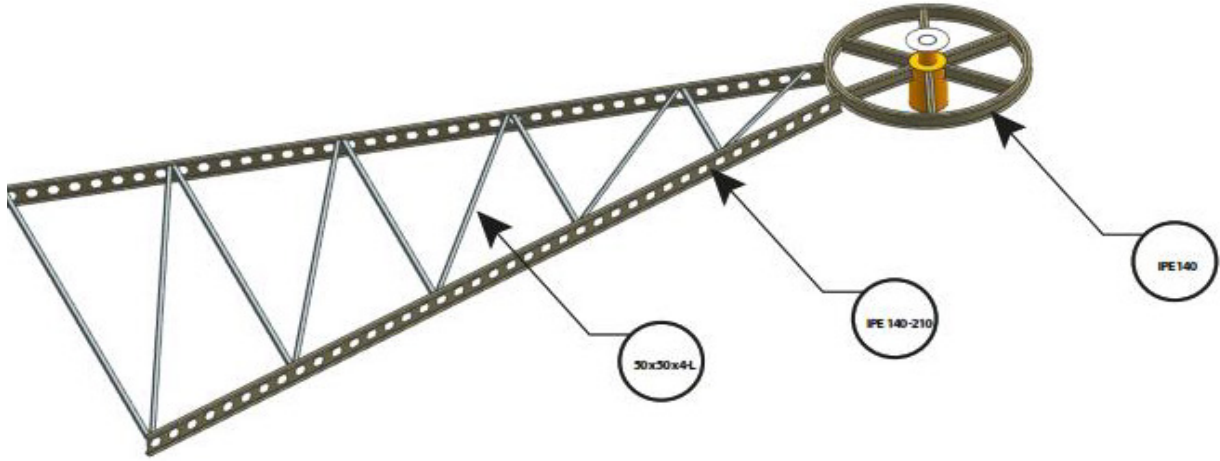

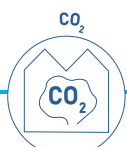
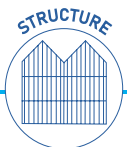
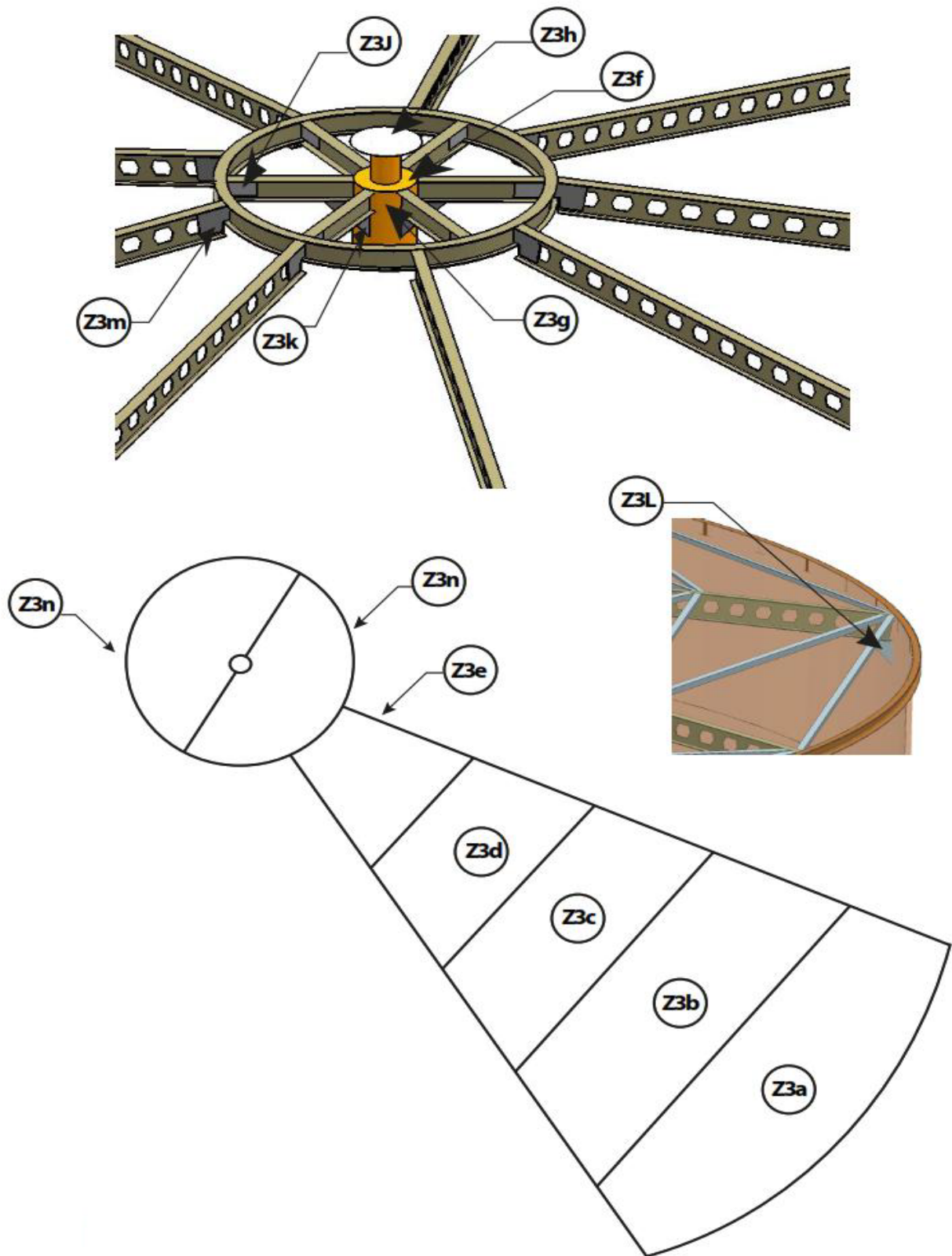

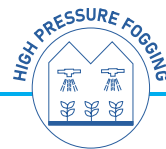
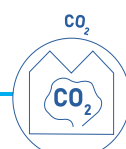
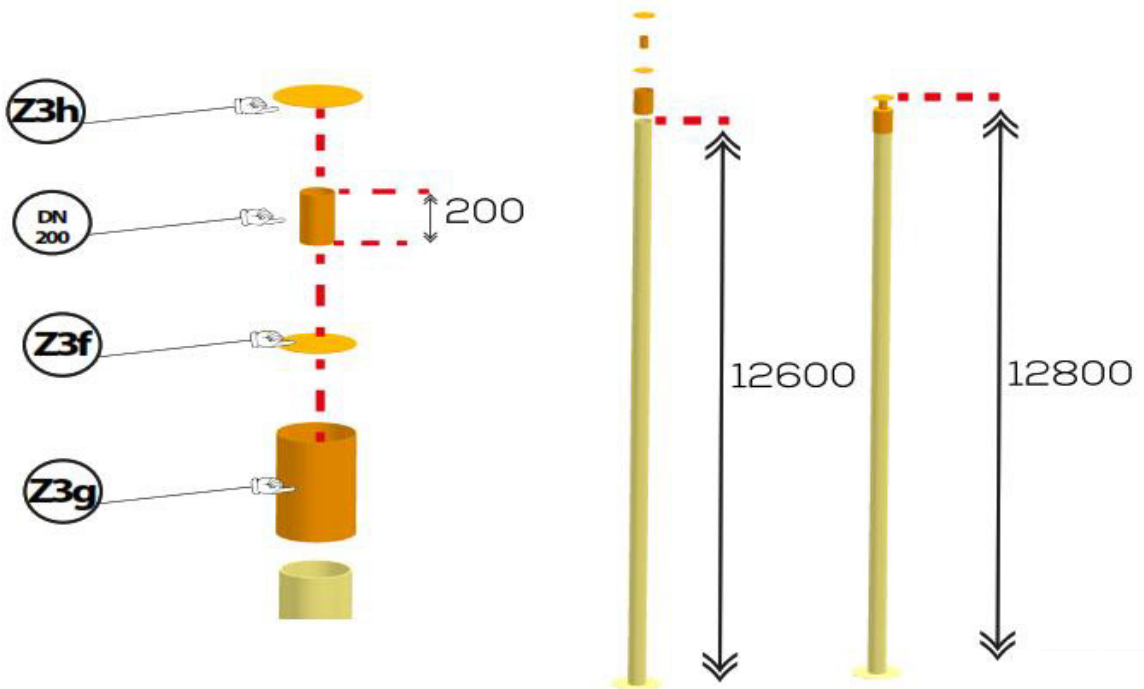
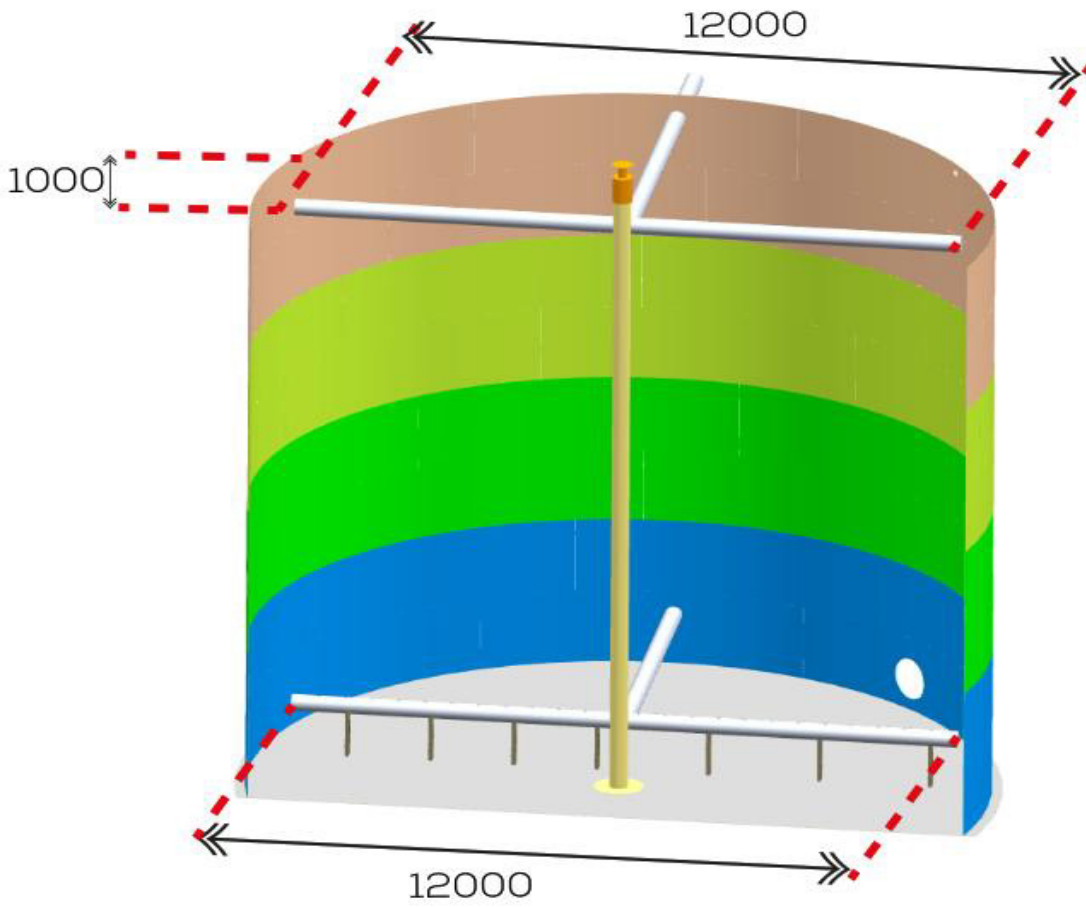

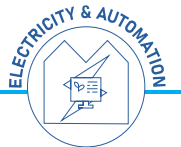
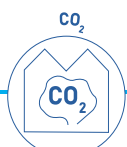
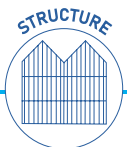
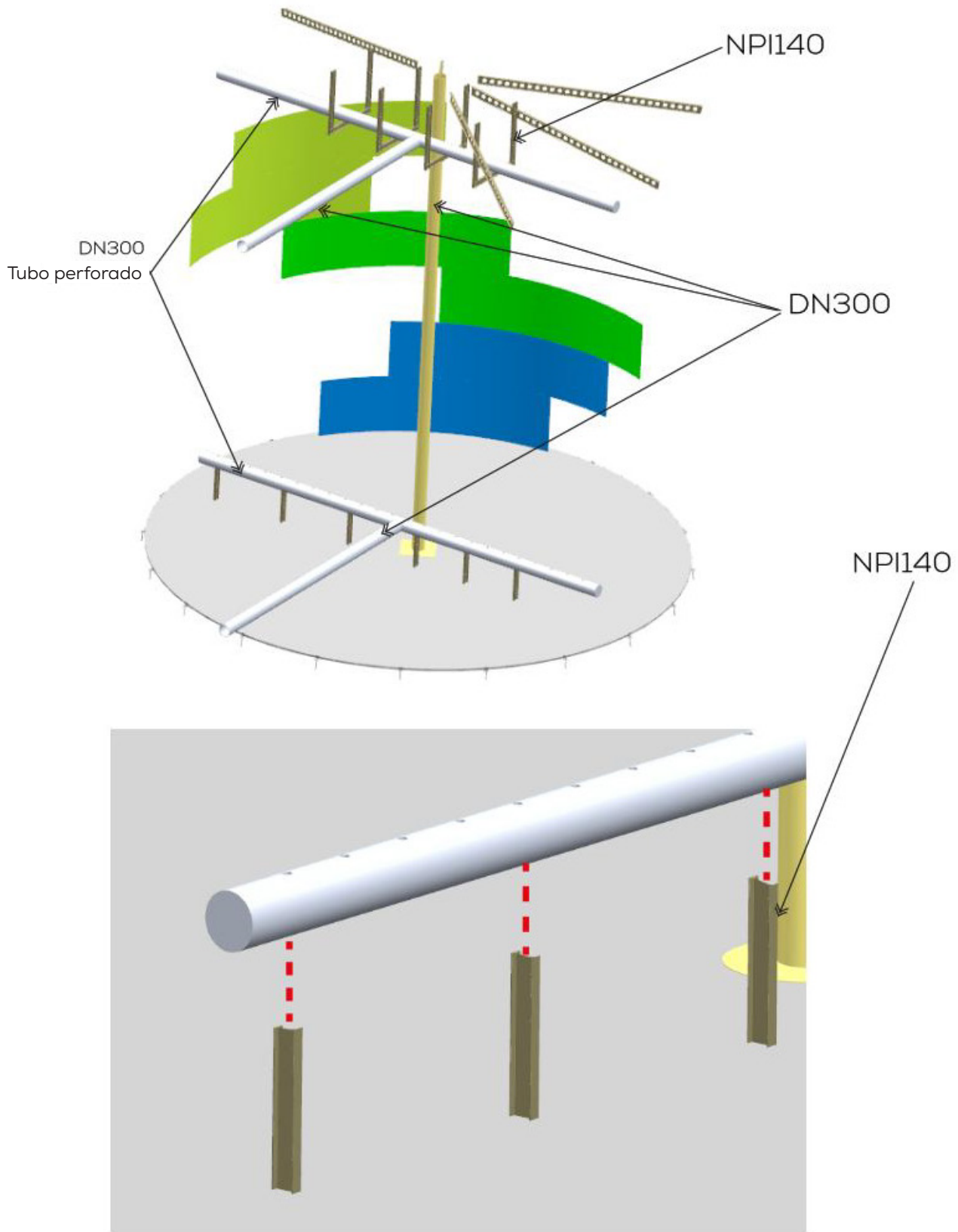

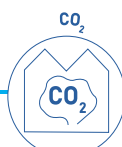
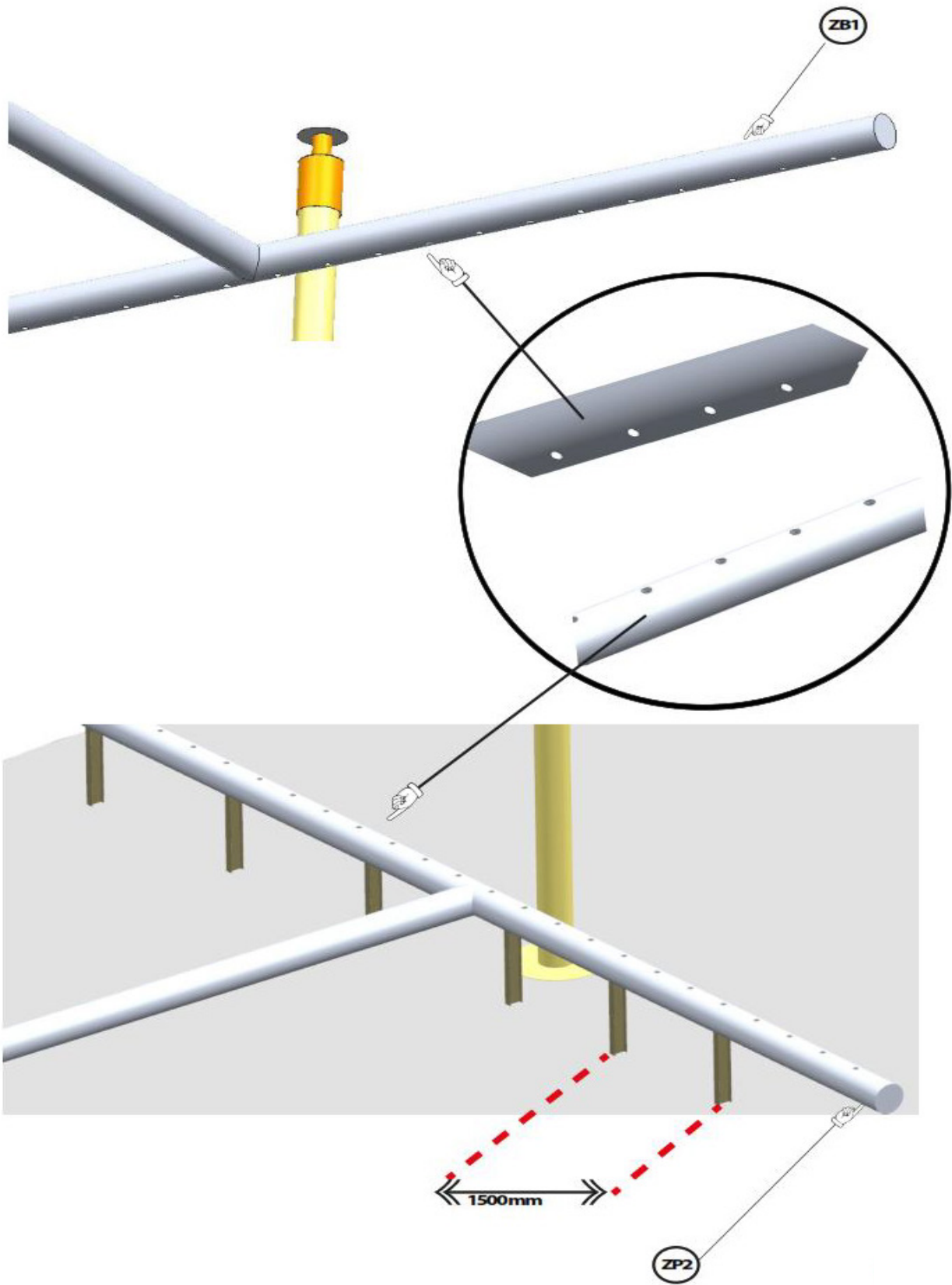

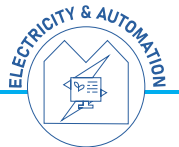
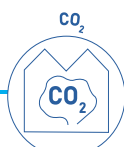
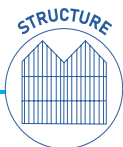
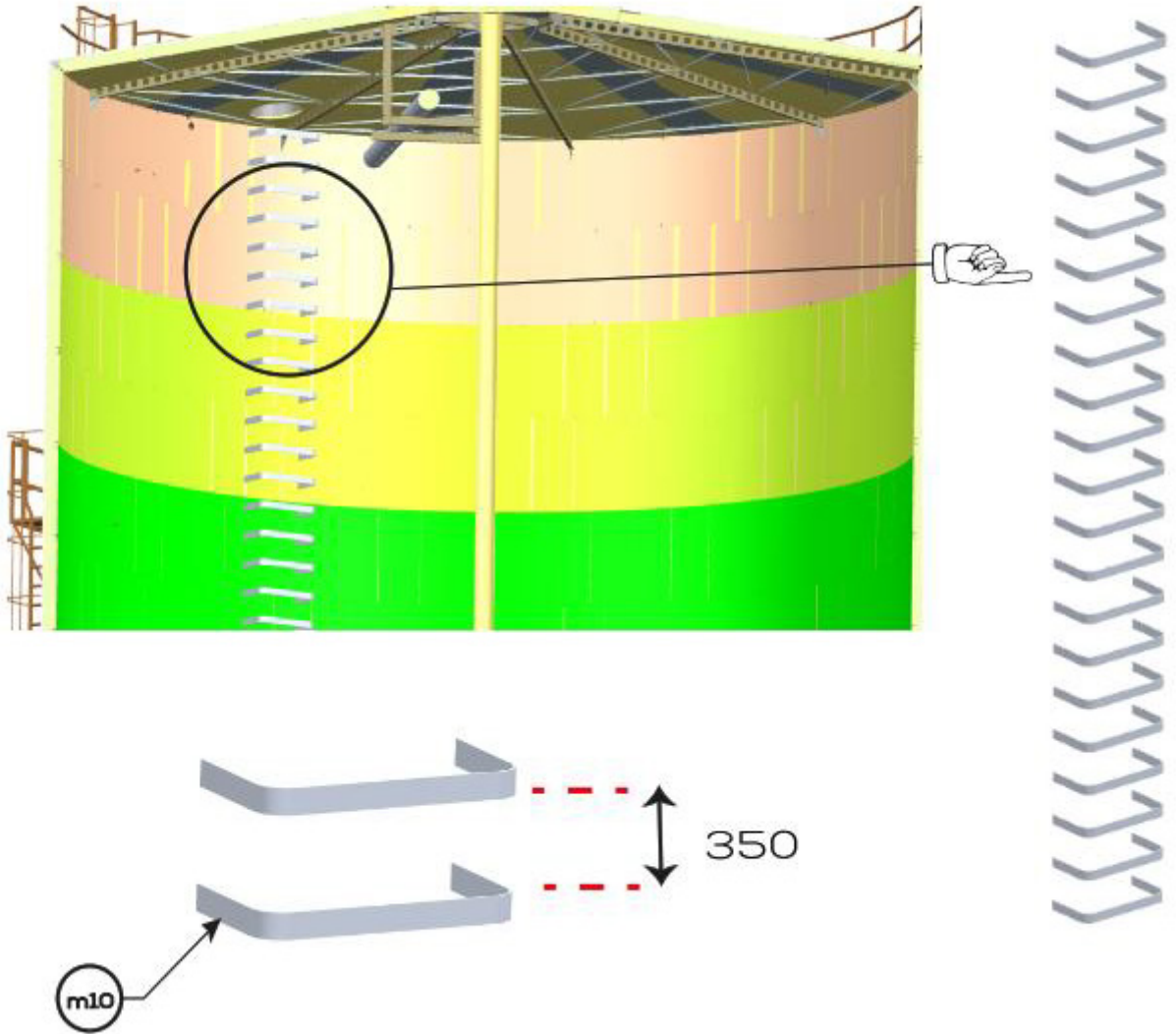

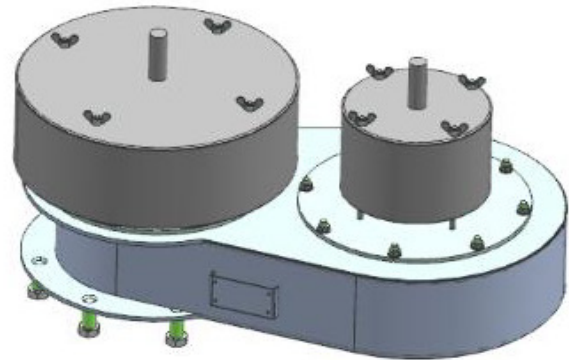
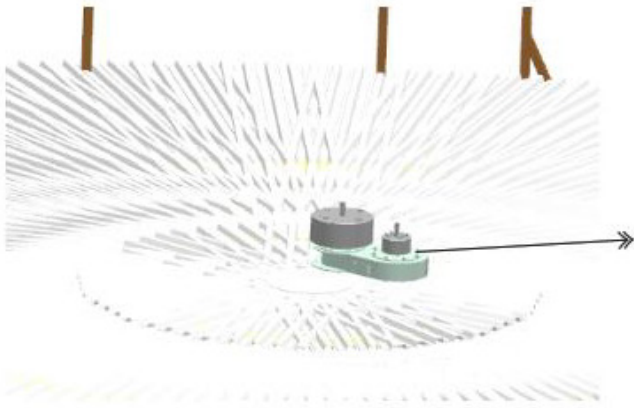

Prescon PV-200

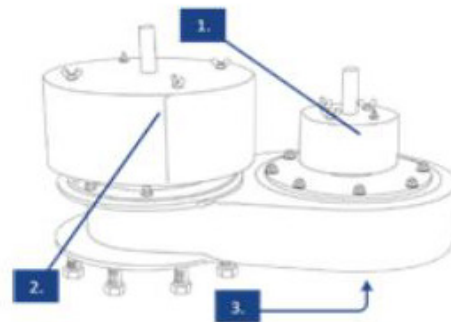
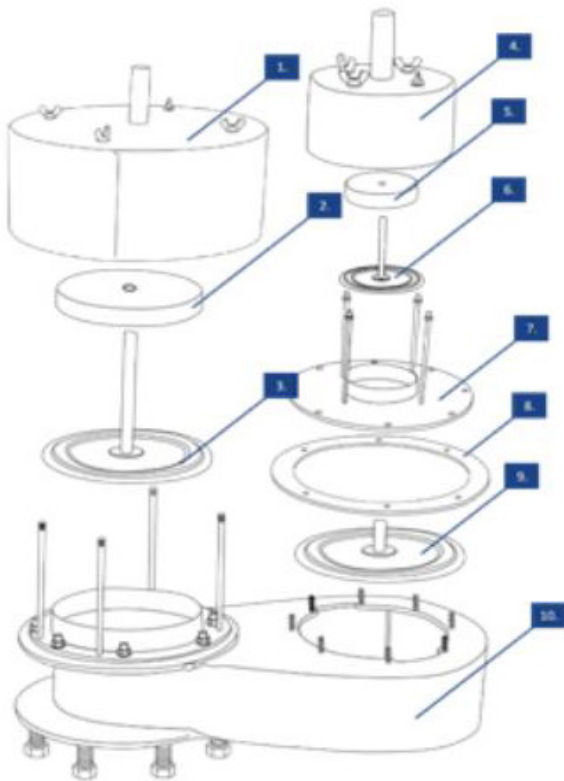

Componentes del diagrama:

1. Tapa de alivio de presión
2. Peso
3. Válvula
4. Tapa de presión de operación
5. Peso de presión de operación
6. Válvula de presión de operación
7. Placa superior
8. Junta de silicona
9. Válvula de vacío
10. Cuerpo de la válvula de seguridad

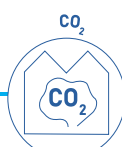

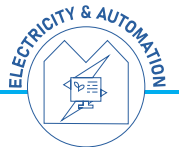
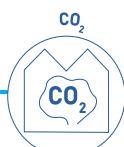
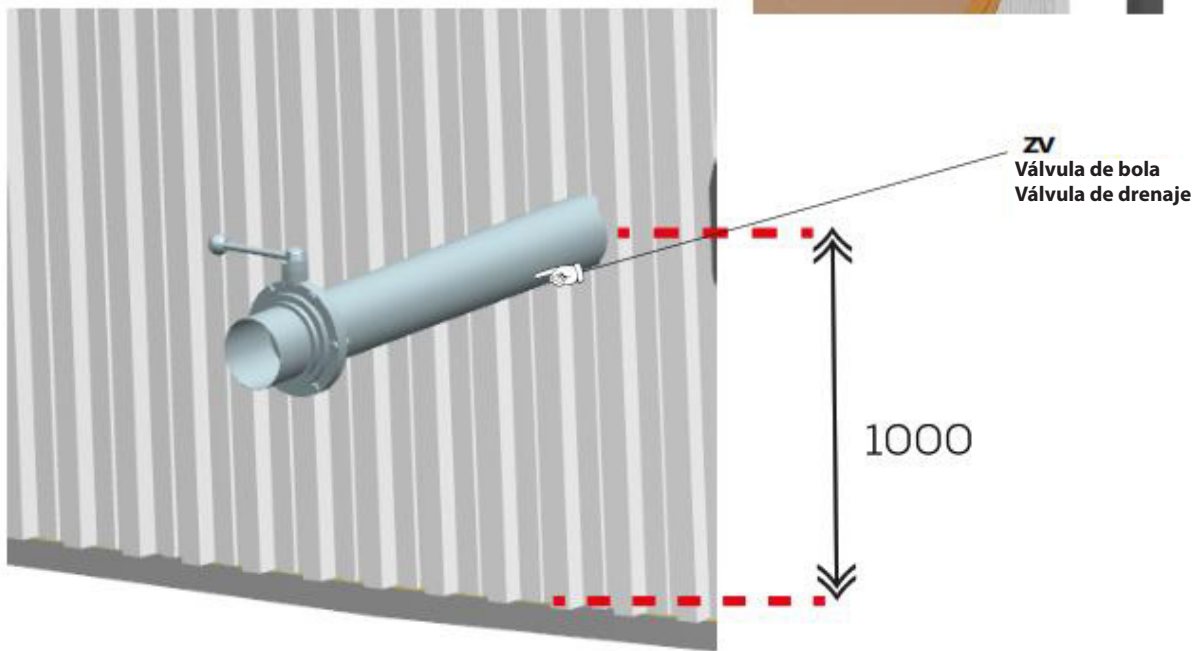
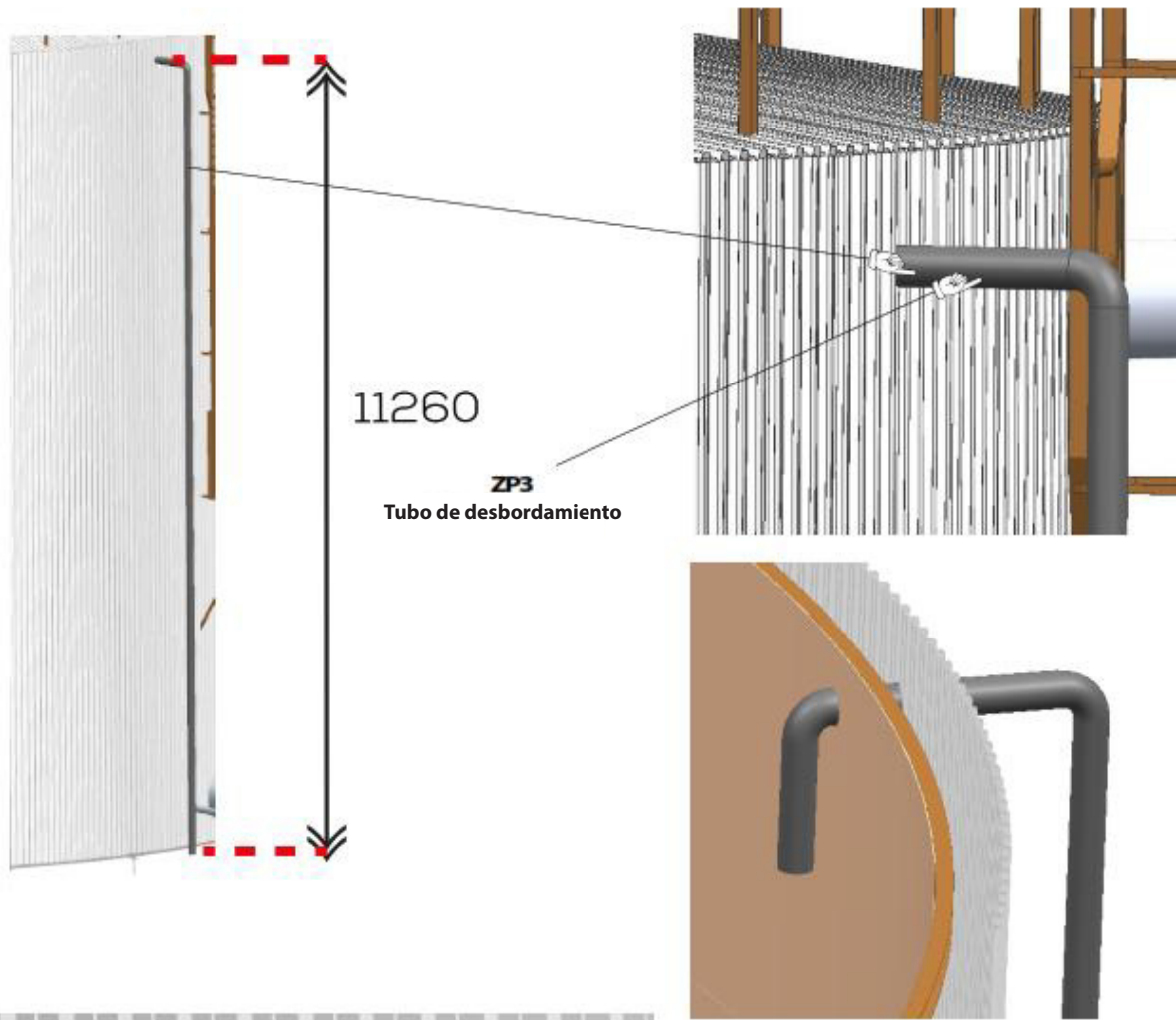

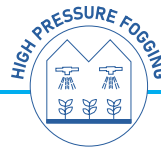
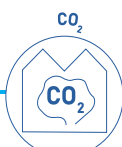
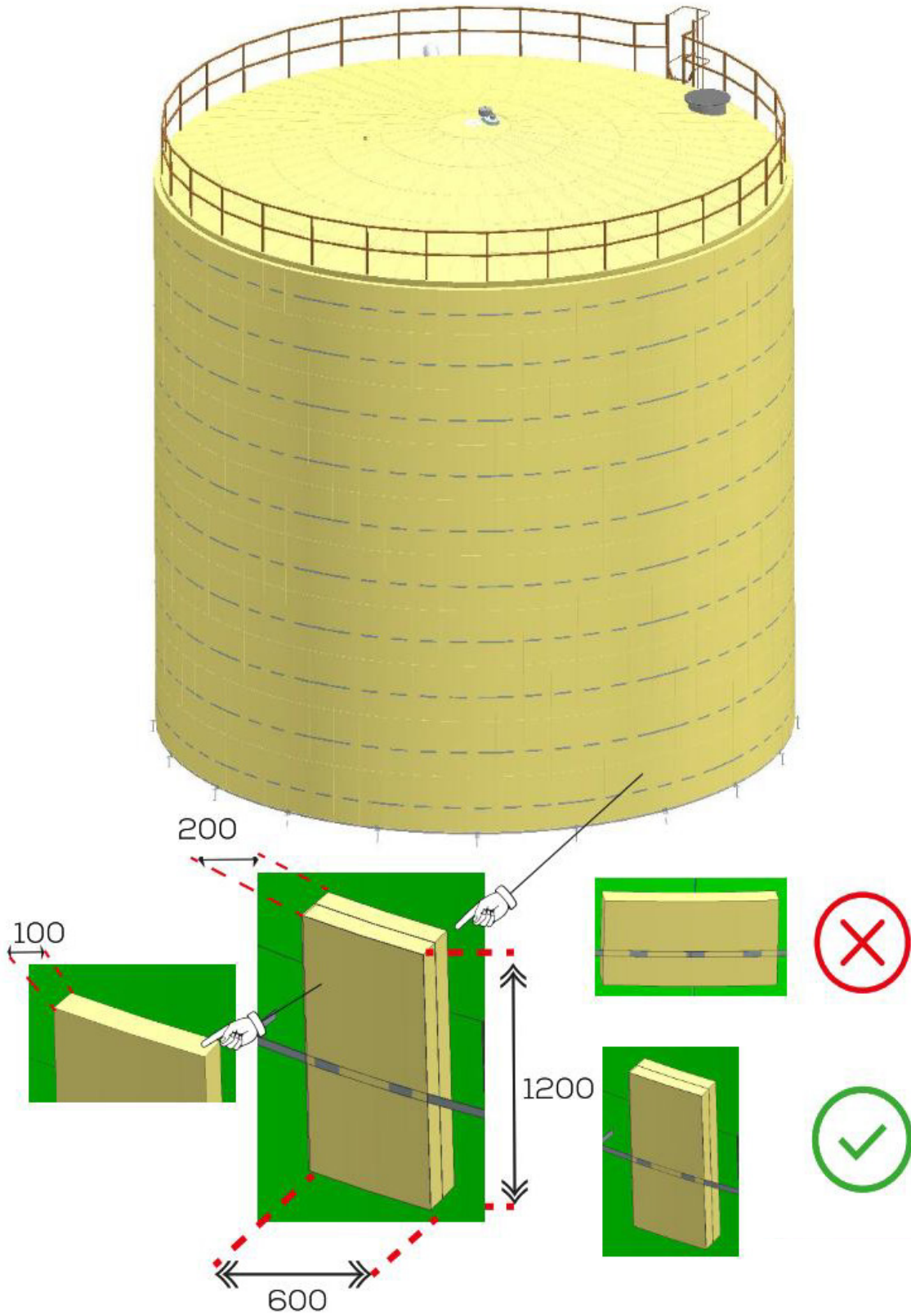

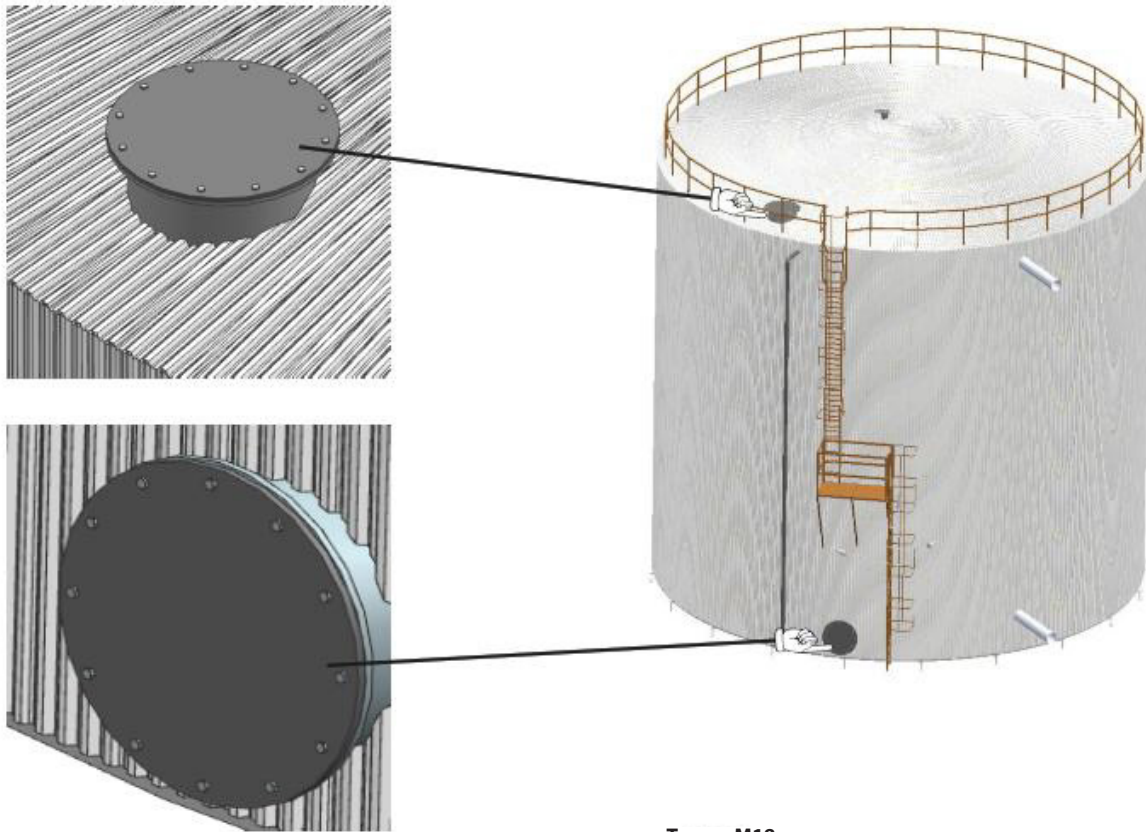

Perno M18
12 piezas

Tuerca M18
12 piezas

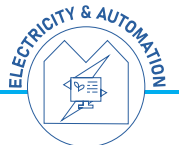
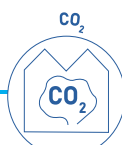
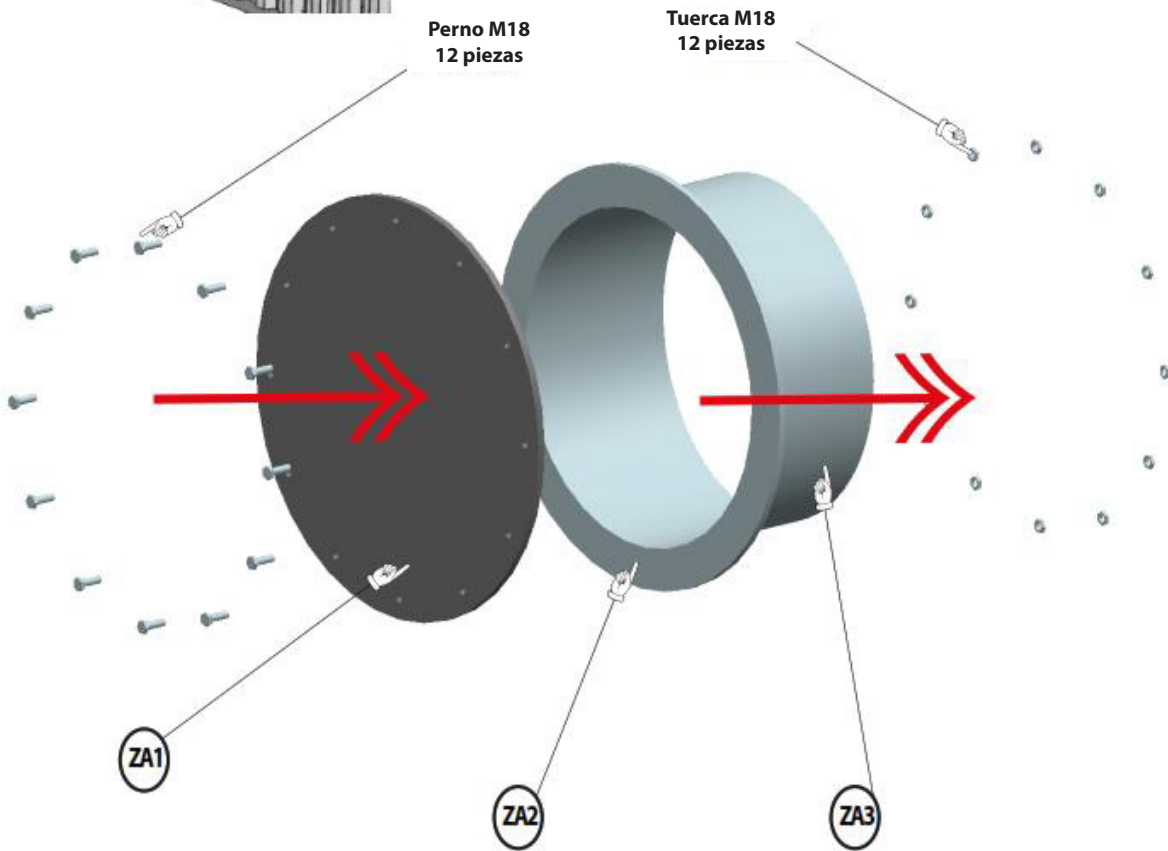

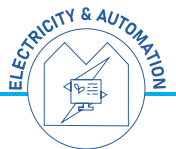
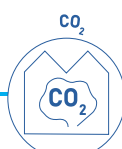
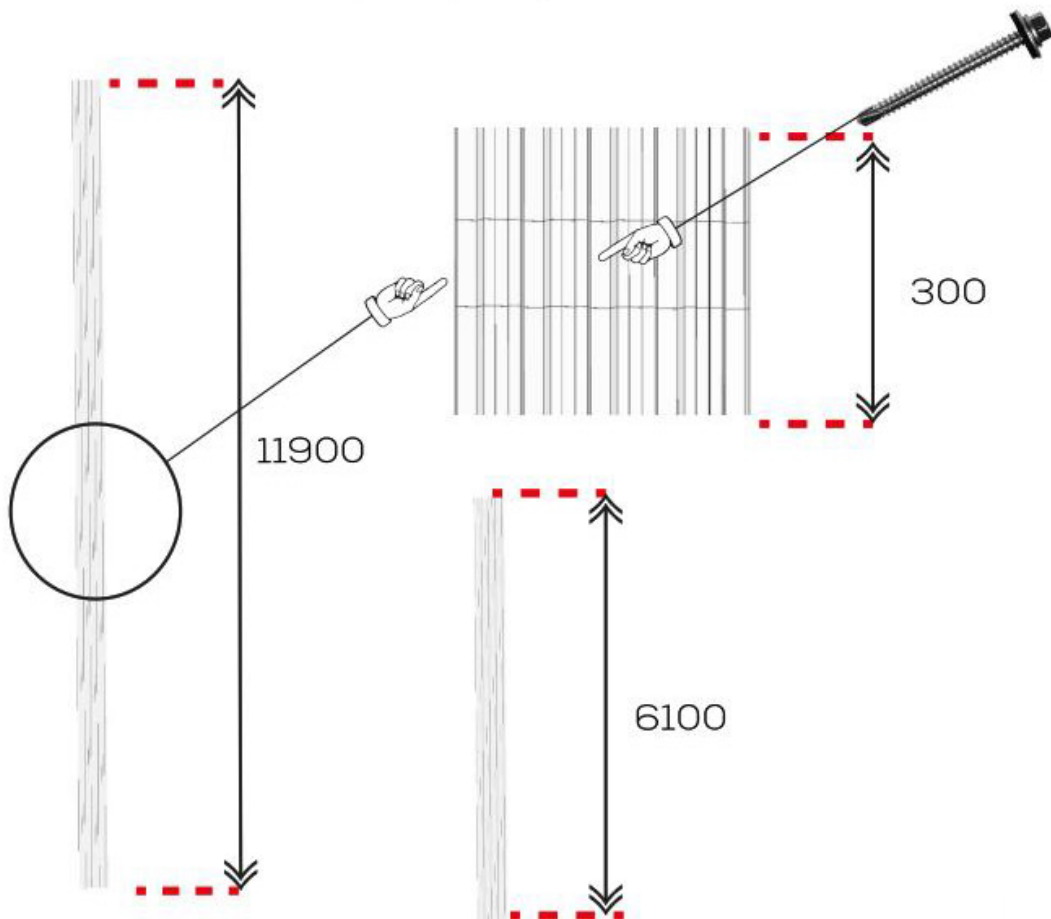

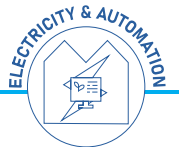
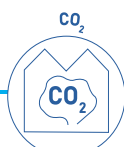
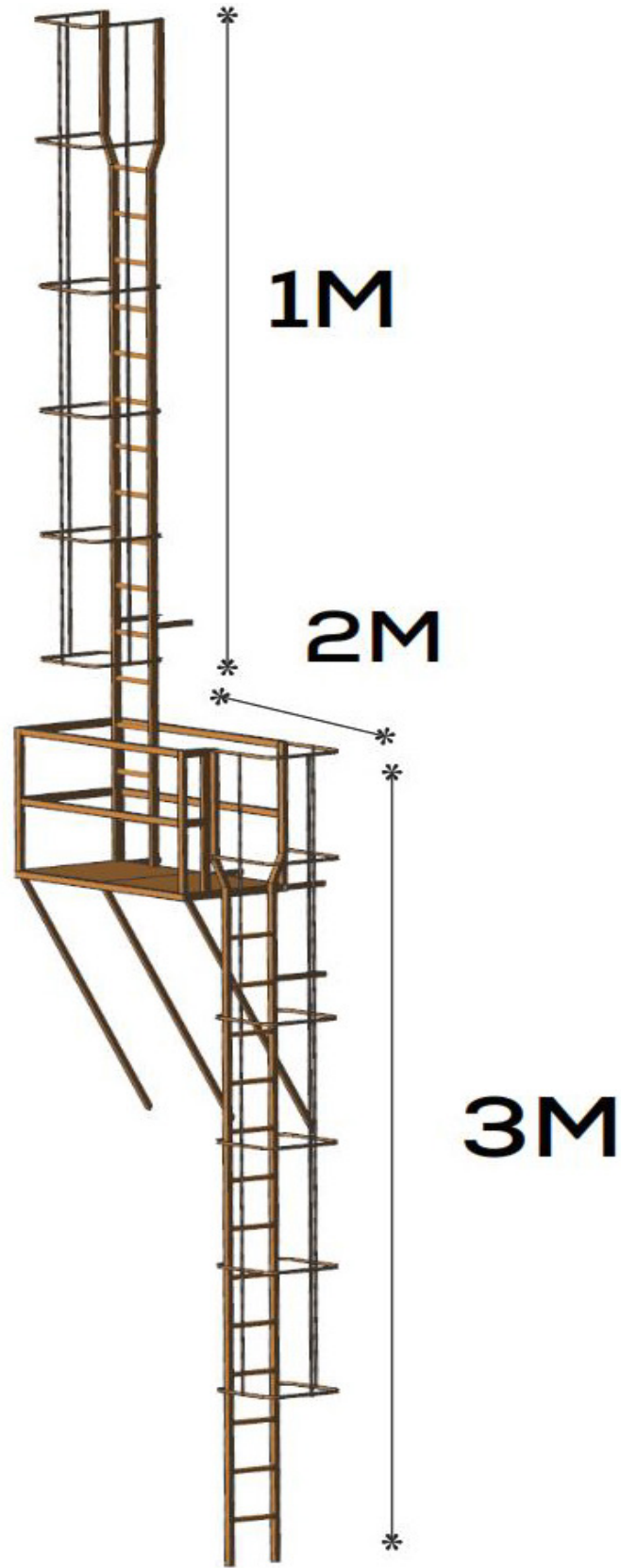

1M

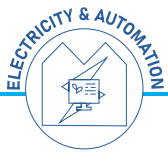
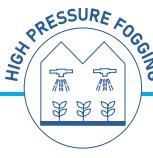
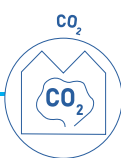
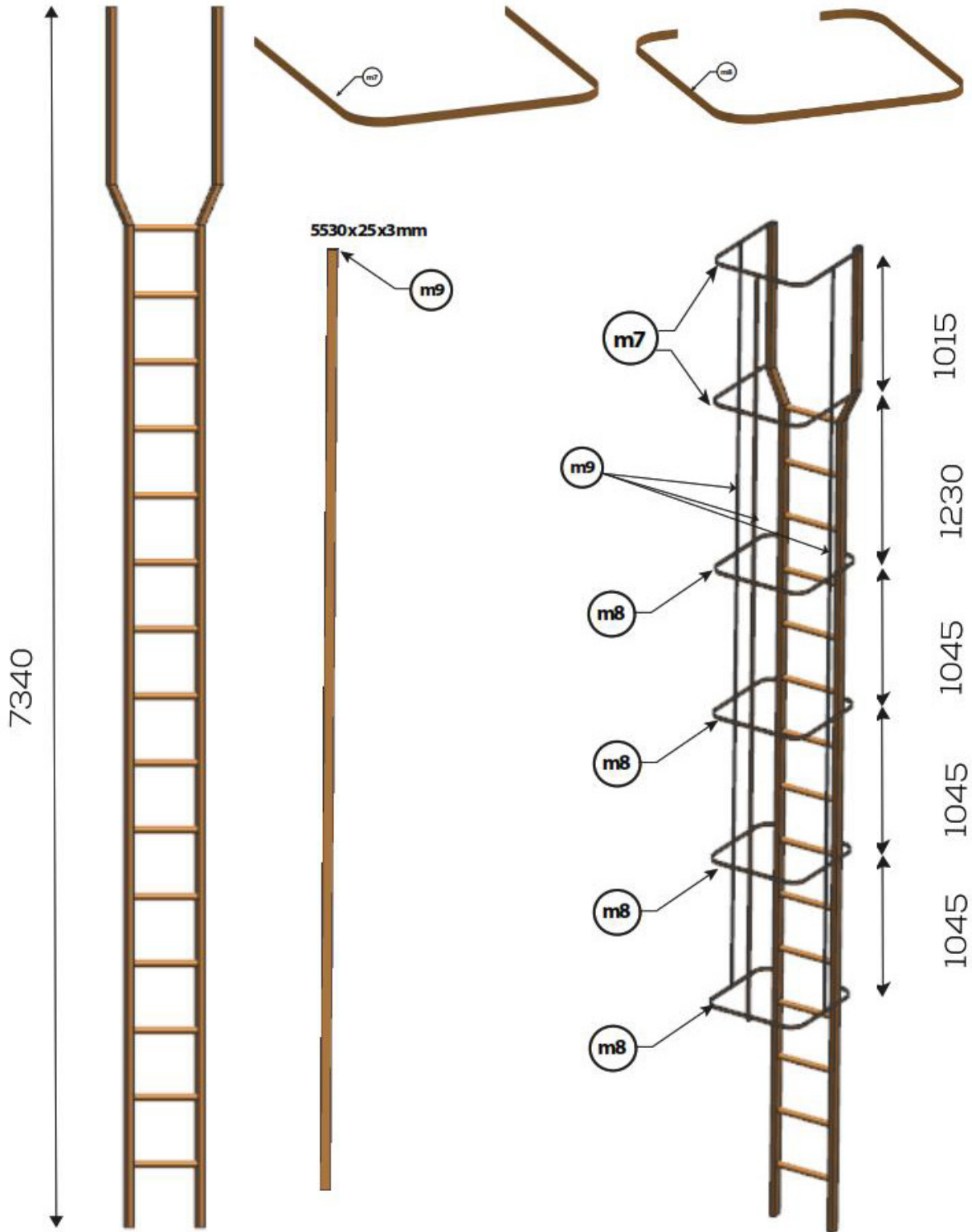

2M

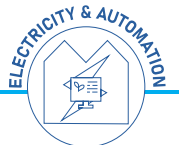
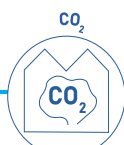
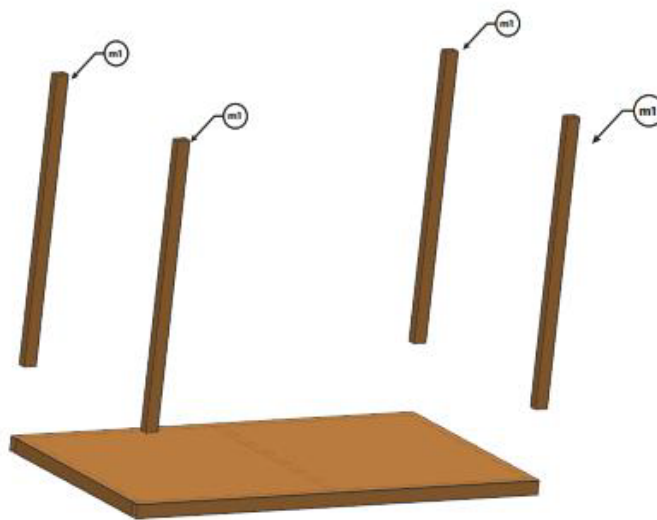
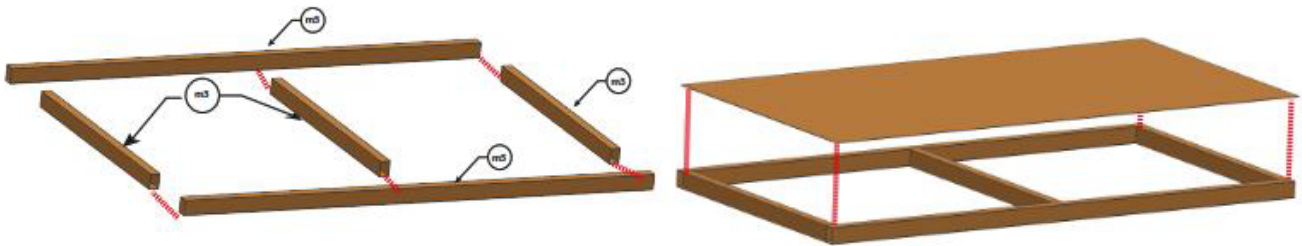
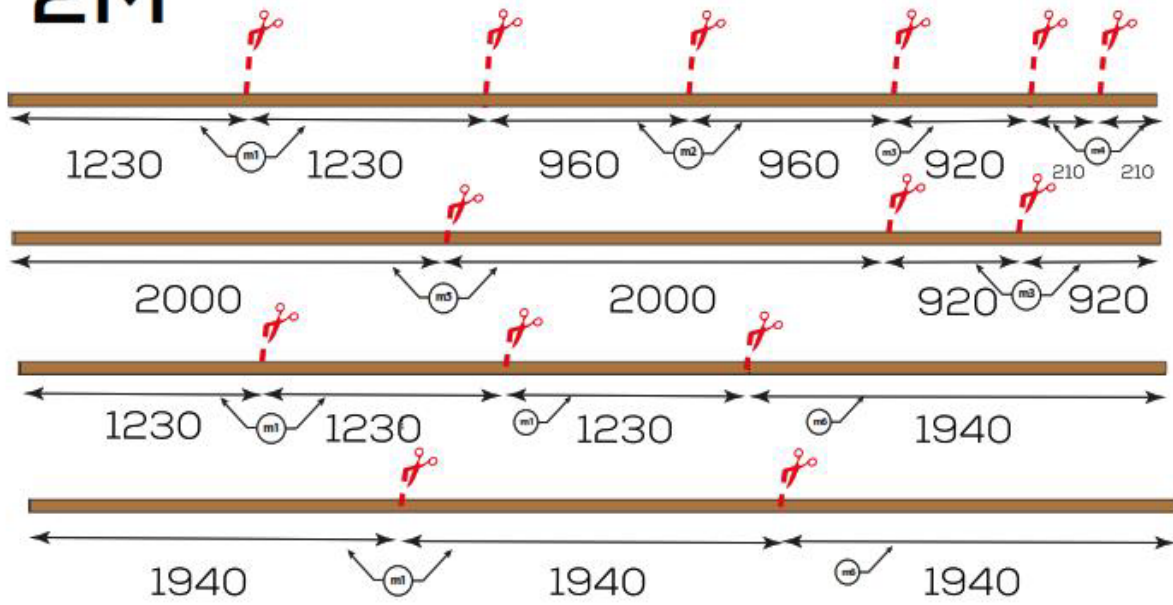

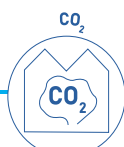
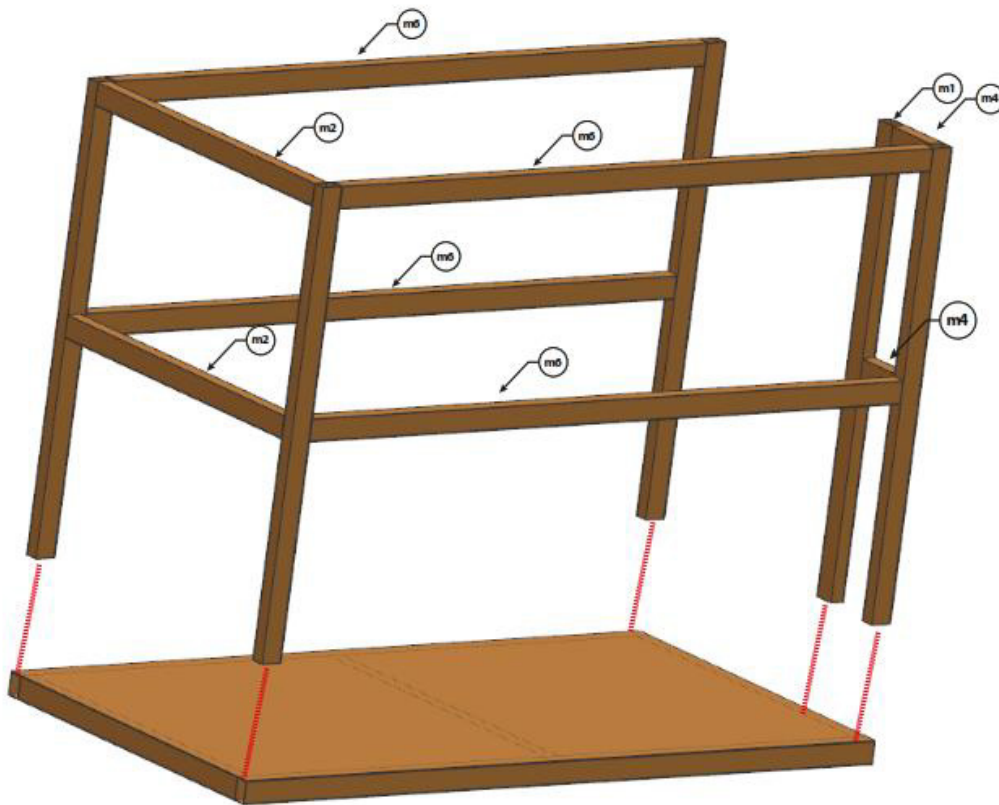

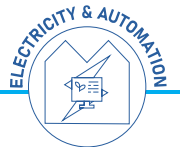
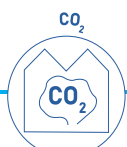
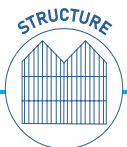
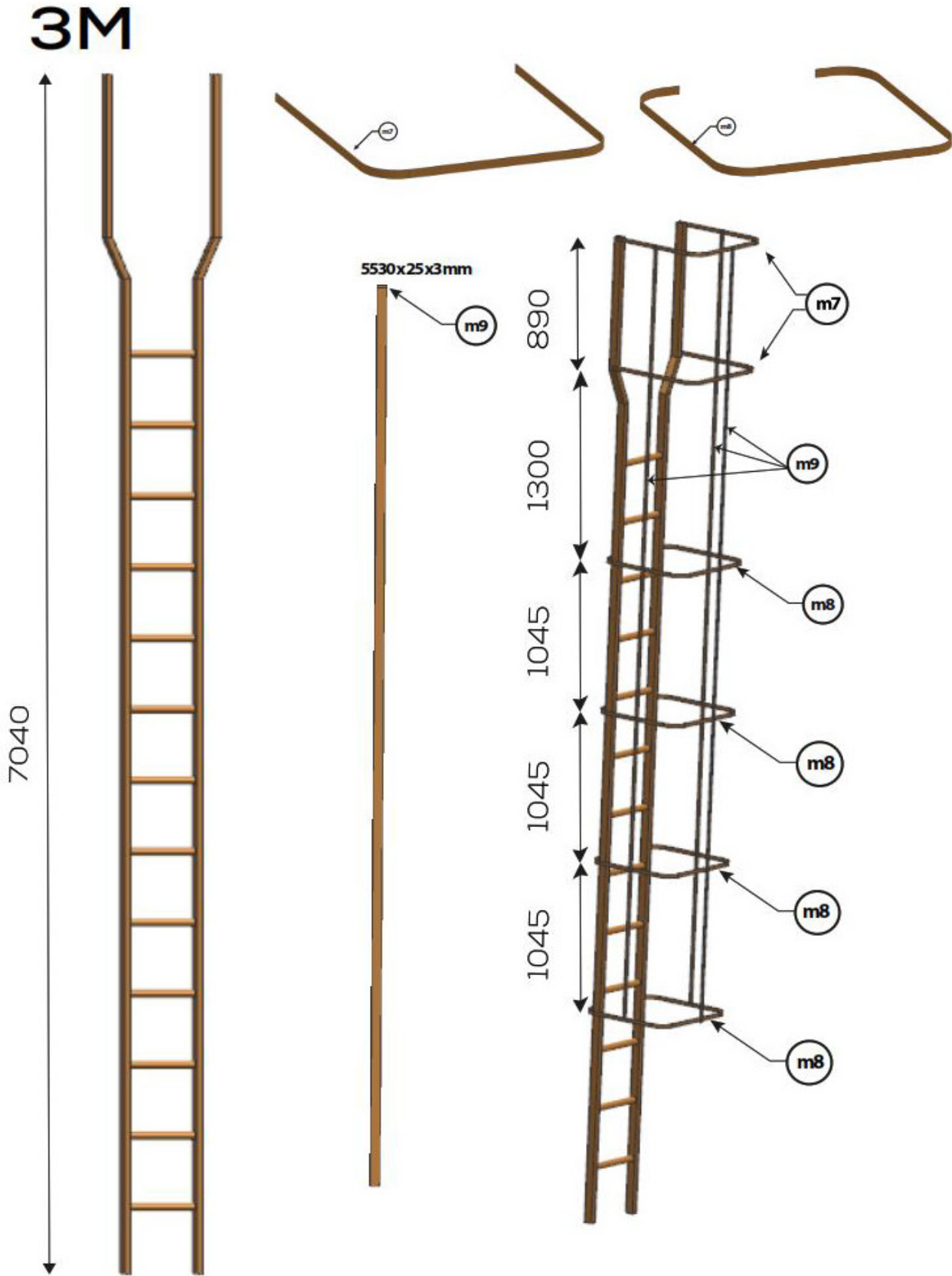

**Çerkeşli Osb Mah. İmes 7.Cadde
No:3 Dilovası/Kocaeli**

+90 262 244 44 94