



BUFFER TANK

MONTAJ TALİMATI

BUFFER TANK

MONTAJ TALİMATI

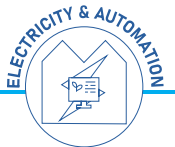
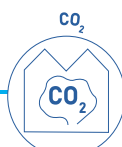
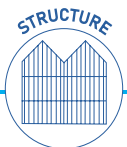

BUFFER TANK

CN	安装说明
CRO	Upute za ugradnju
CZ	Návod k instalaci
DK	Montagevejledning
E	Instrucciones de montaje
F	Instructions de montage
GB	Installation instructions
GR	Οδηγία συναρμολόγησης
H	Szerelési utasítás
I	Istruzioni di montaggio
NL	Montagehandleiding
P	Instrução de montagem
S	Monteringsanvisningz
SER	Uputstvo za montažu
SF	Asennusohje
SK	Návod na montáž
SLO	Navodila za montažo
TR	Montaj talimatı
PL	Instrukcja montazu
NO	Installasjonsanvisning
RU	Указания по установке
ROM	Instrucțiuni de montare

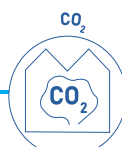



2500 TON

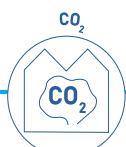
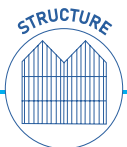

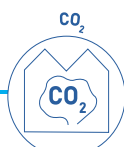
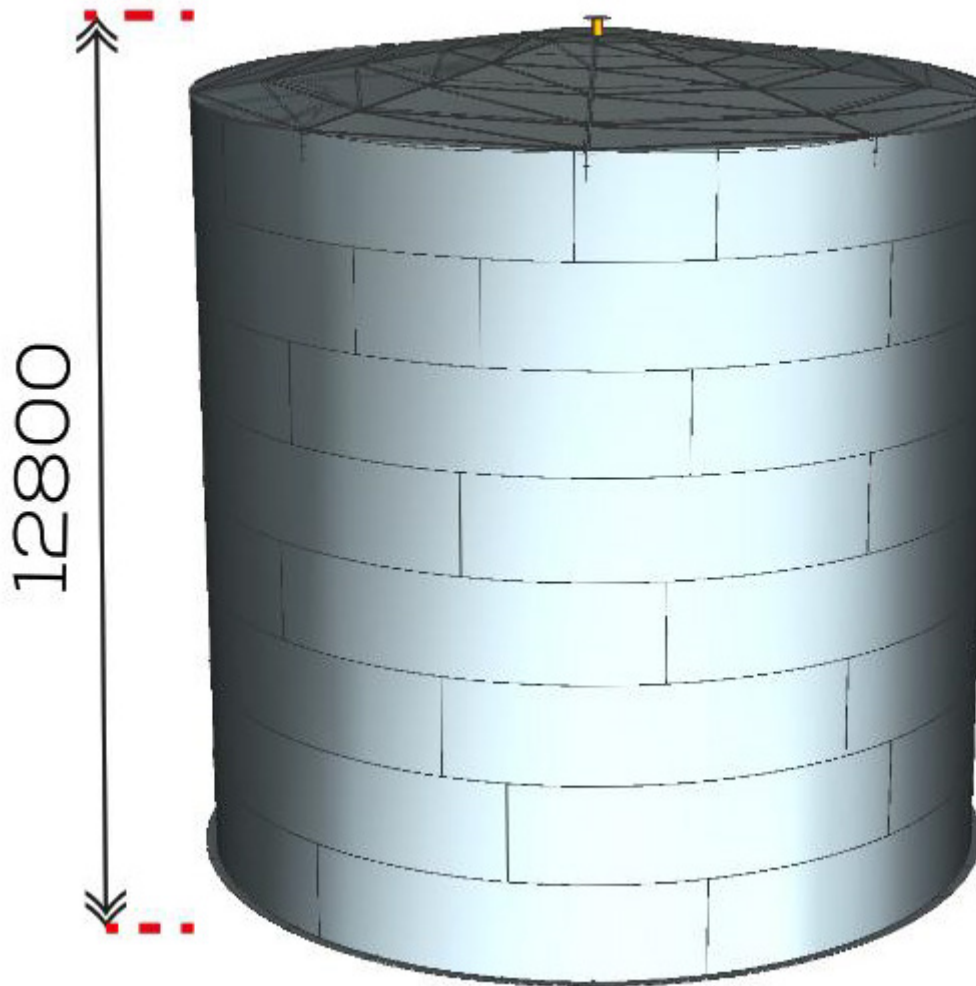

2500 TON



1. TRUCK



2. TRUCK



3. TRUCK



4. TRUCK

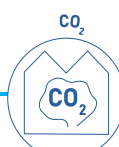

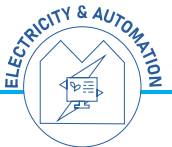
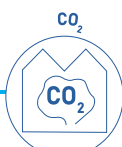
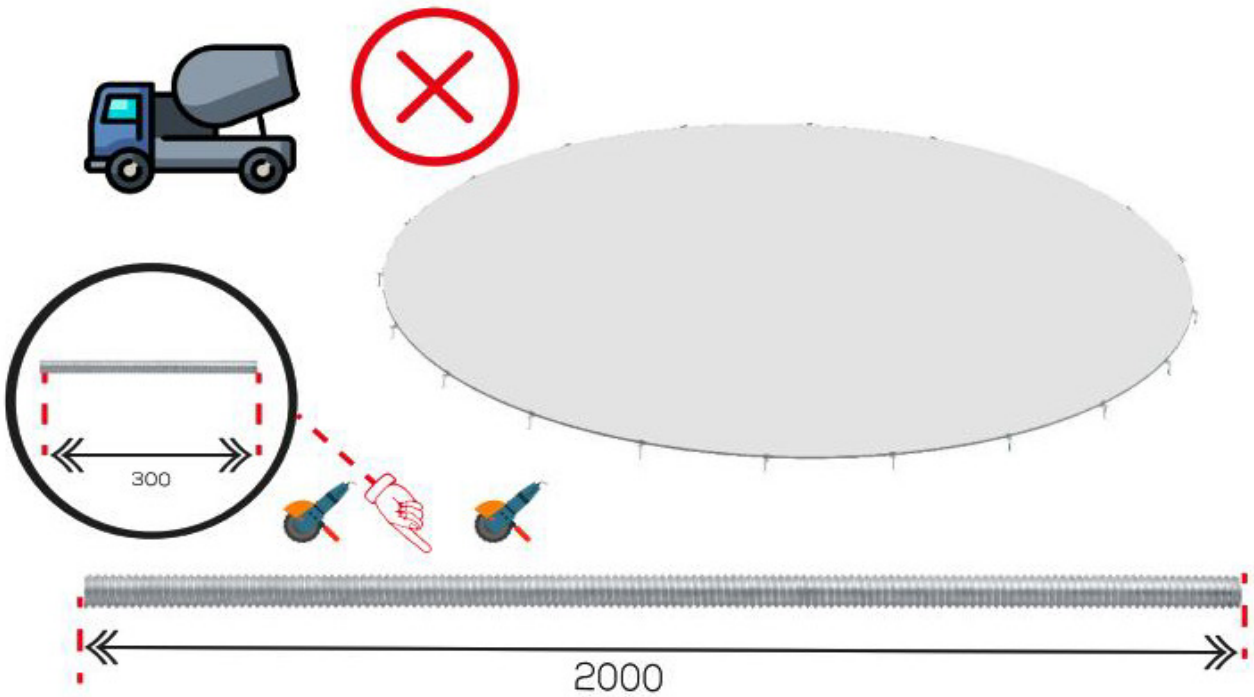
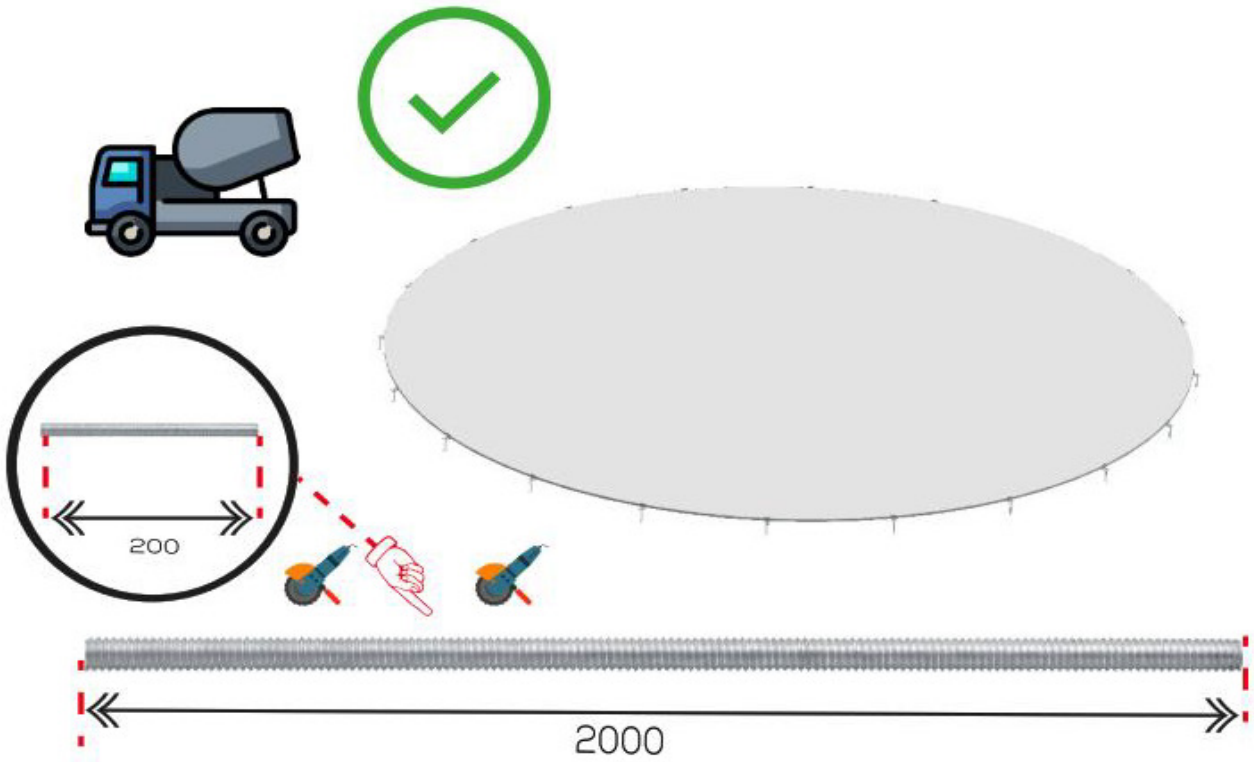

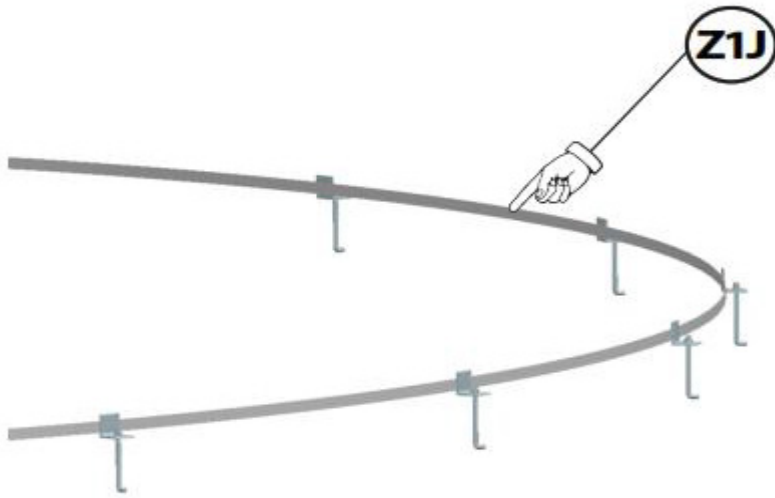
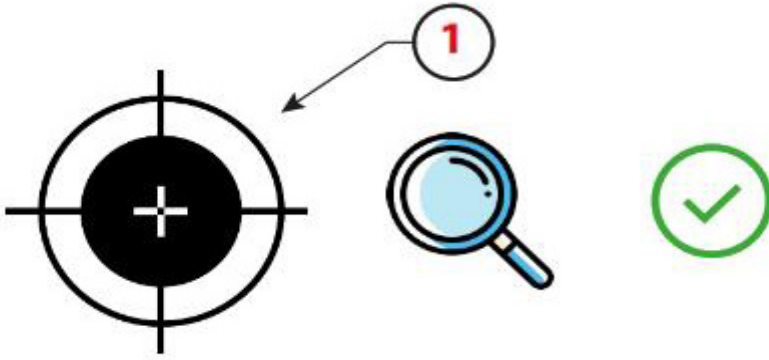

XPS izolasyonları ve yağlı kum

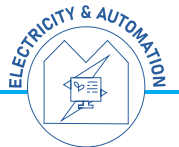
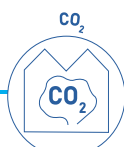
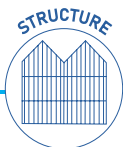
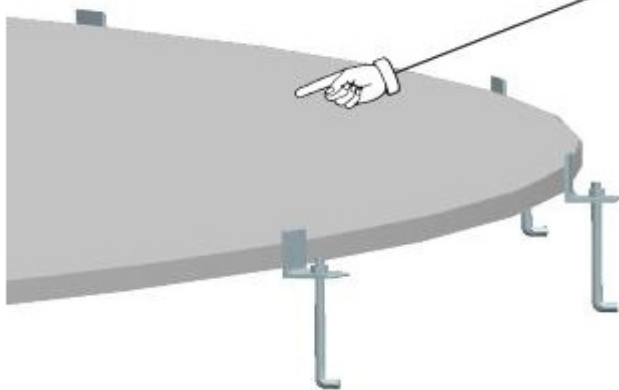

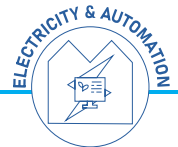
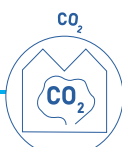
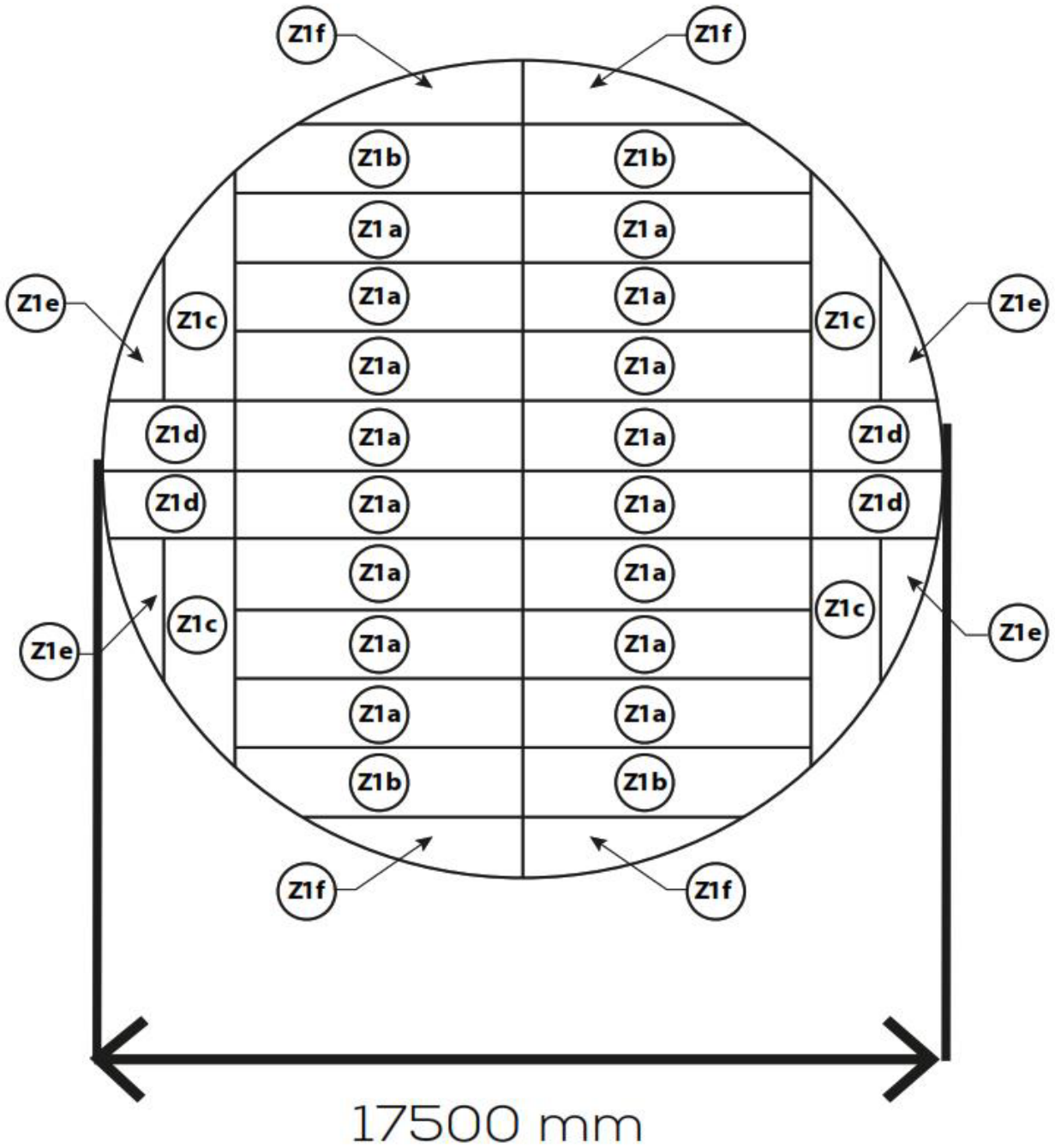



1

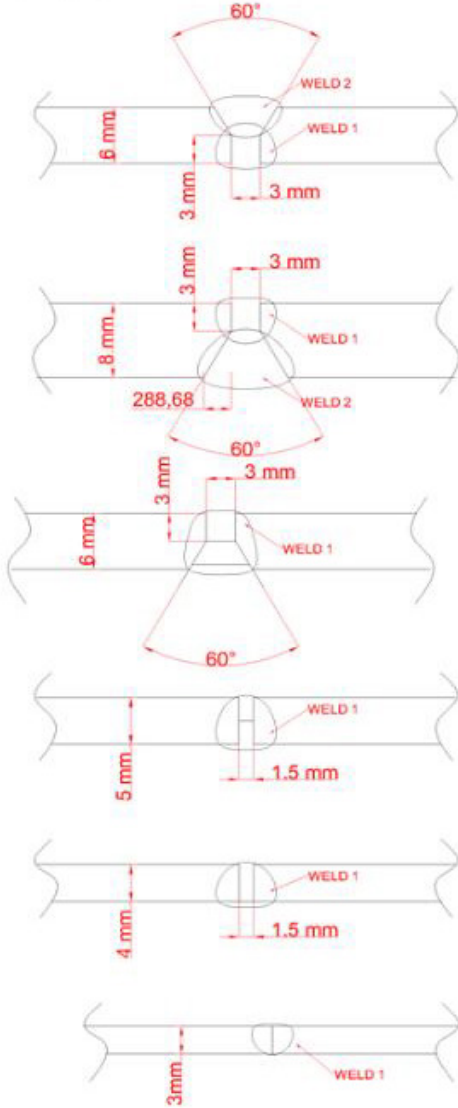

TABAN PLAKASI KAYNAĞI

KAYNAK AĞZI : Yukarıda
KAYNAK : weld 1= 4mm - 130A
weld 2= 5mm - 170A
KAYNAK HIZI : 5m/h

DUVAR PLAKASI KAYNAĞI

KAYNAK AĞZI : Dışarıda
KAYNAK ŞEKLİ: Aşağıdan yukarıya ▲
KAYNAK : weld 1=4mm - 130A
weld 2=4mm - 180A
KAYNAK HIZI : 3m/h

DUVAR PLAKASI KAYNAĞI

KAYNAK AĞZI : Dışarıda
KAYNAK ŞEKLİ: Aşağıdan yukarıya ▲
KAYNAK : 3.25mm-110A
KAYNAK HIZI : 4.6m/h

DUVAR PLAKASI KAYNAĞI

KAYNAK AĞZI : Yok
KAYNAK ŞEKLİ: Aşağıdan yukarıya ▲
KAYNAK : weld 1= 3.25mm-110A
KAYNAK HIZI : 6m/h

DUVAR PLAKASI KAYNAĞI

KAYNAK AĞZI : Yok
KAYNAK ŞEKLİ : Aşağıdan yukarıya ▲
KAYNAK : weld 1= 4mm-120A
KAYNAK HIZI : 20m/h

TAVAN PLAKASI KAYNAĞI

KAYNAK AĞZI : Yok
KAYNAK ŞEKLİ : weld 1= 4mm - 115A
KAYNAK HIZI : 27m/h

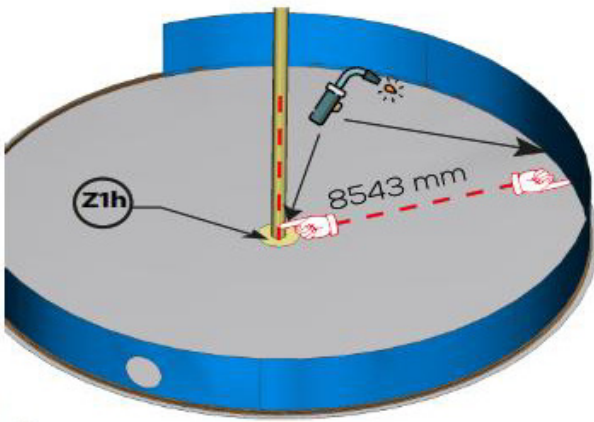

2

STRUCTURE



HEATING



CO₂



VENTILATION & COOLING



HIGH PRESSURE FOGGING



AIR HANDLING UNIT (GAU)

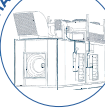

IRRIGATION



ELECTRICITY & AUTOMATION



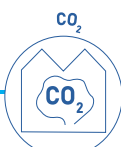
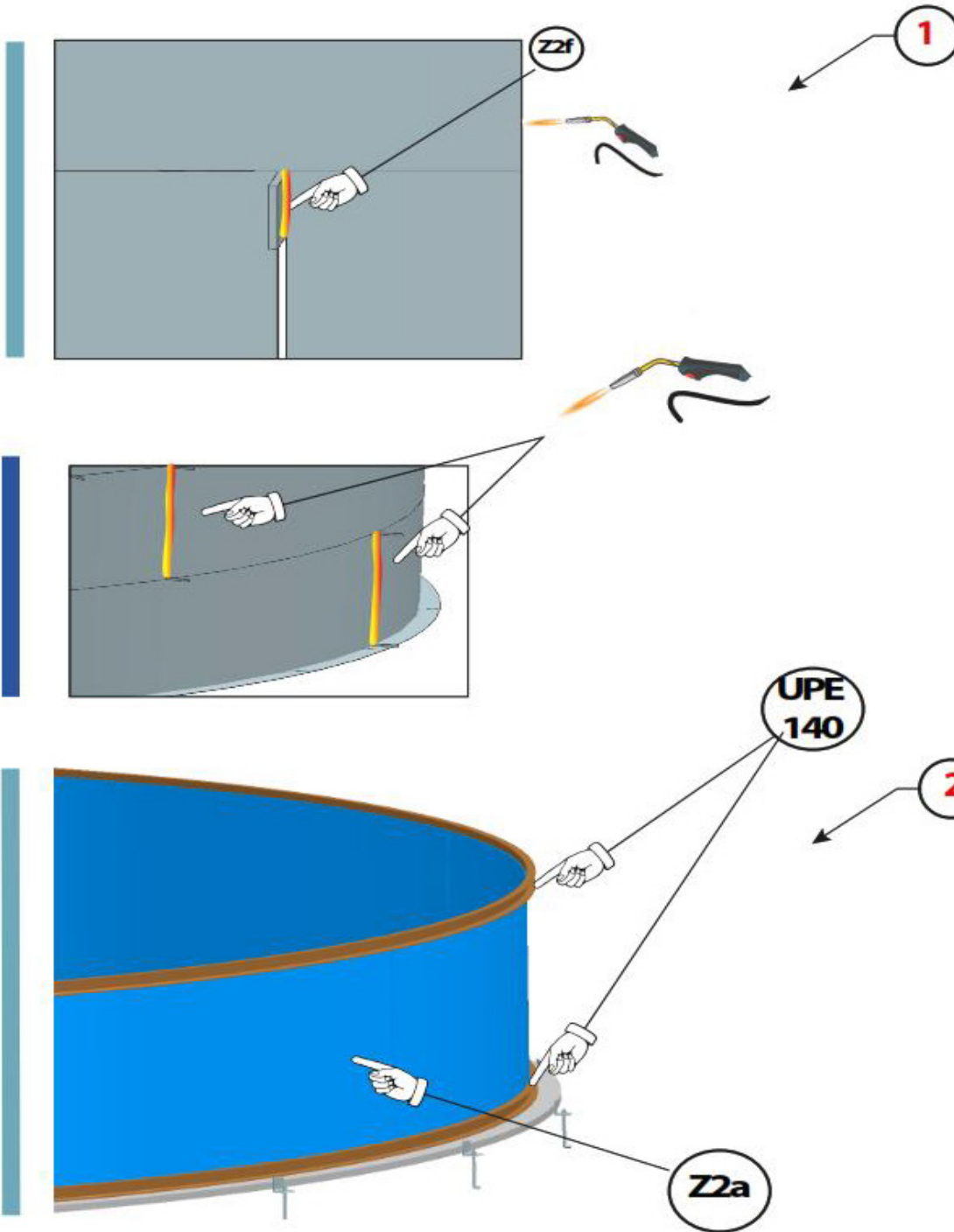

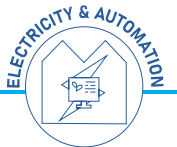
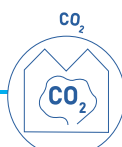
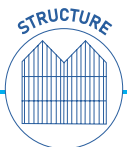
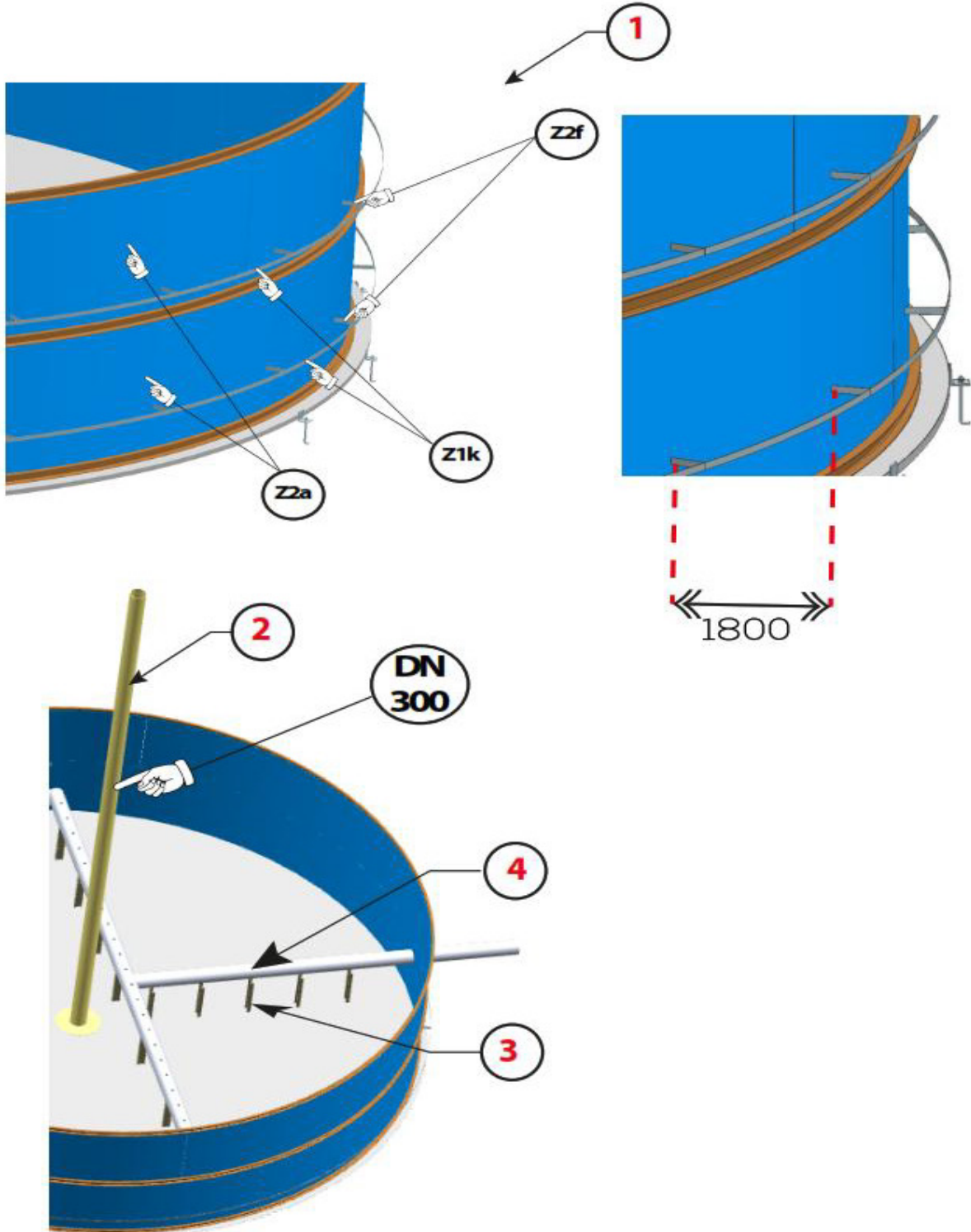

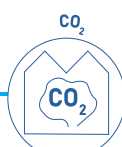
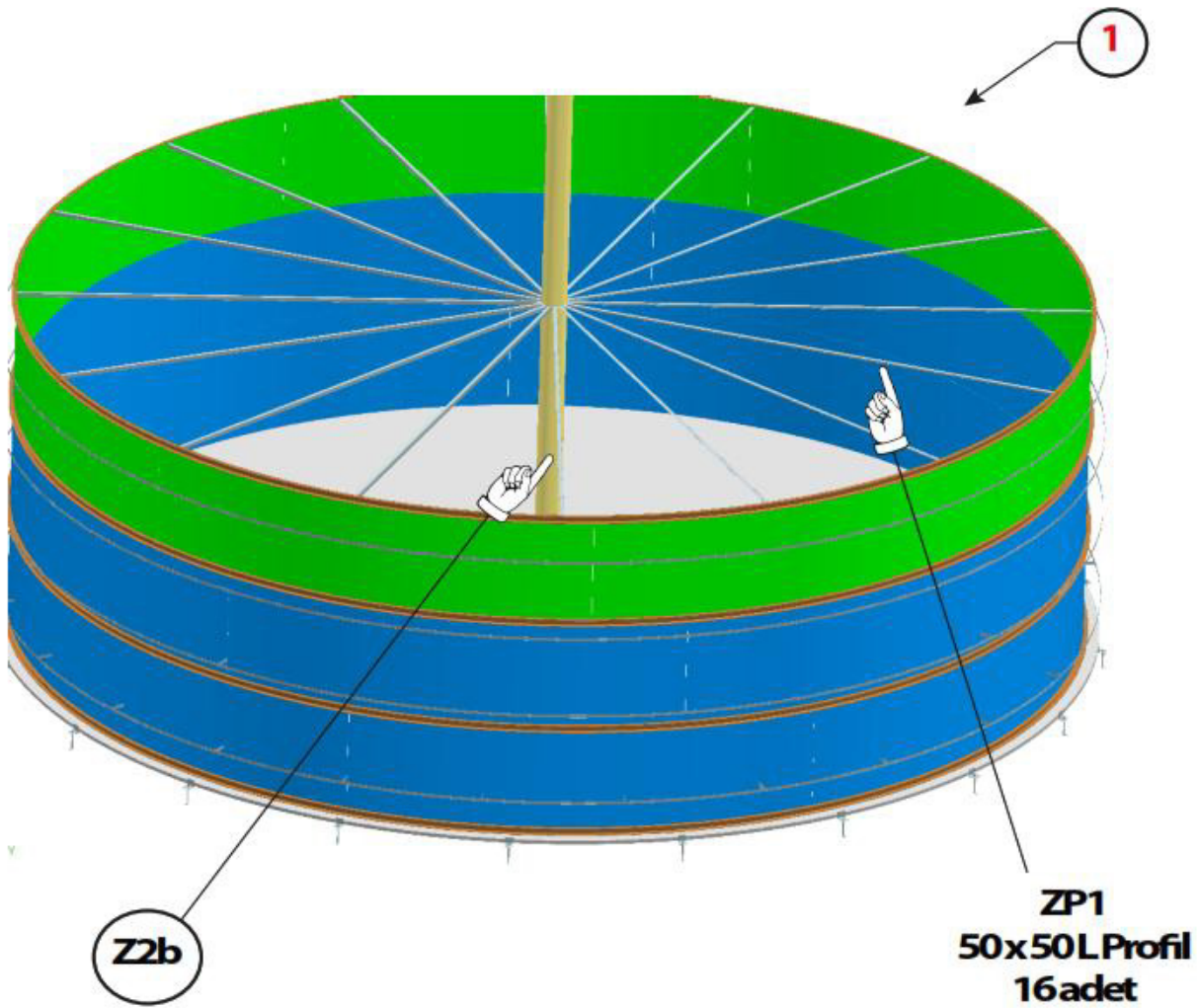

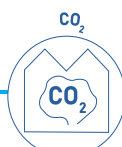
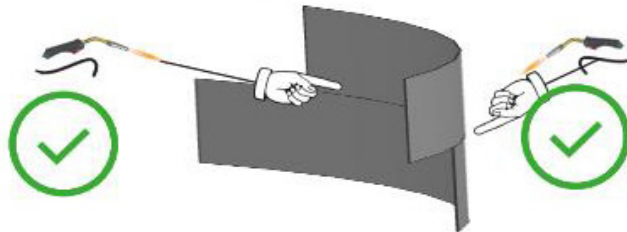
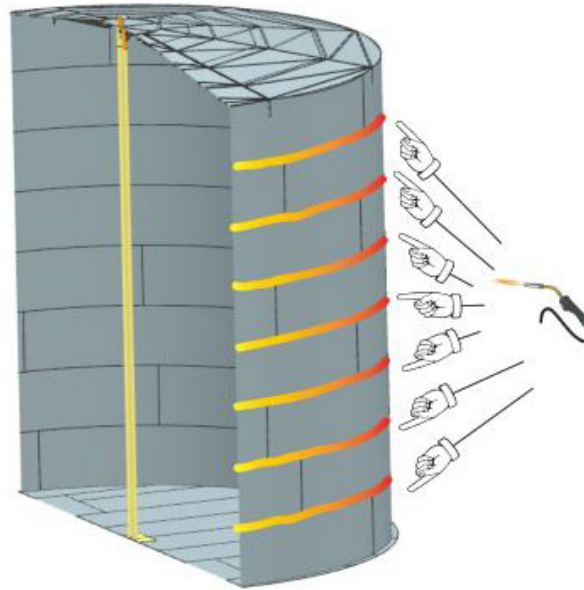
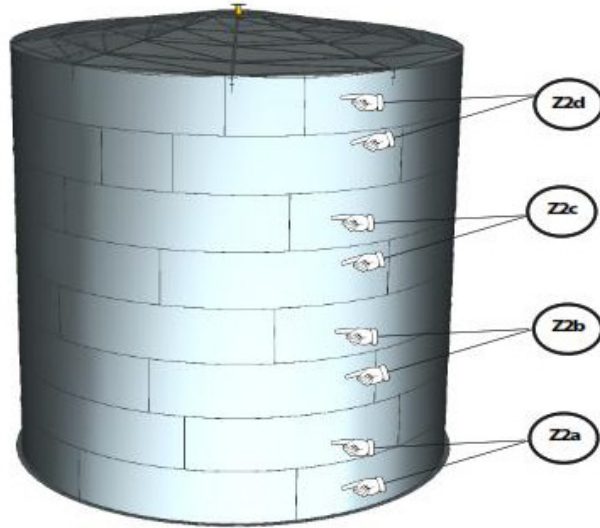

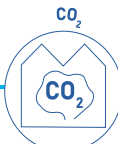
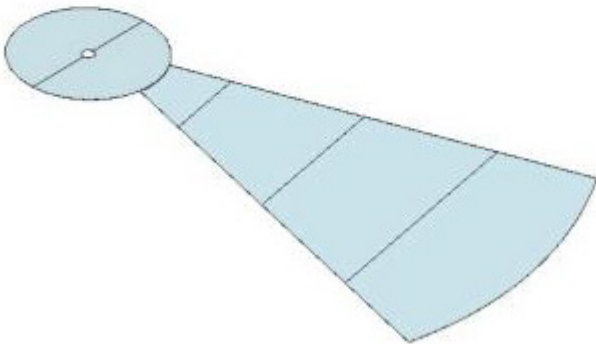
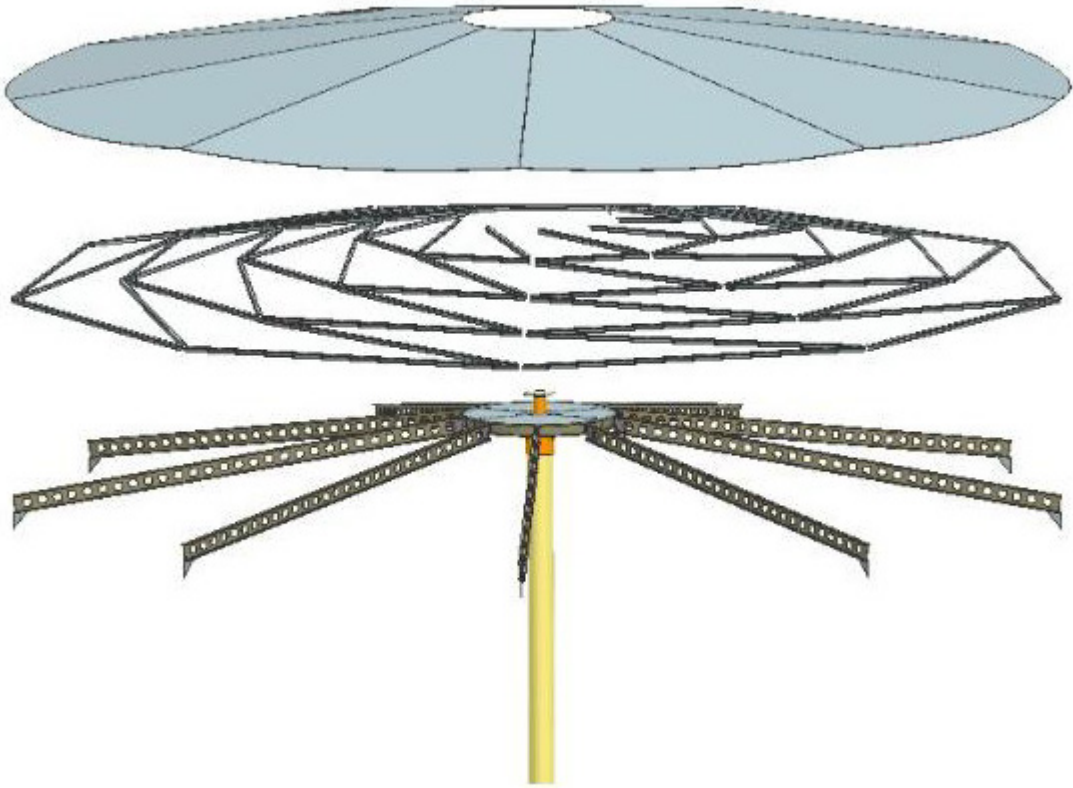

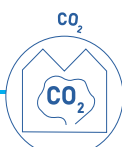
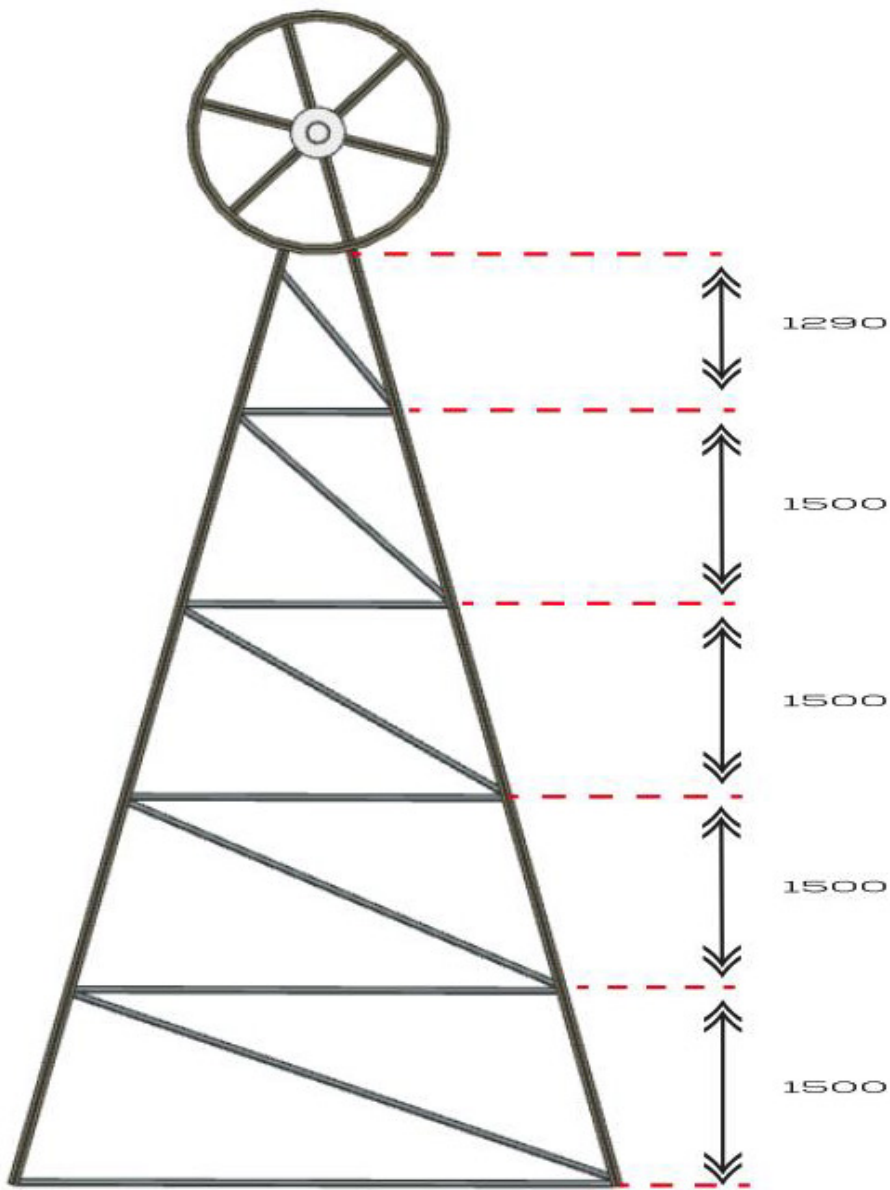
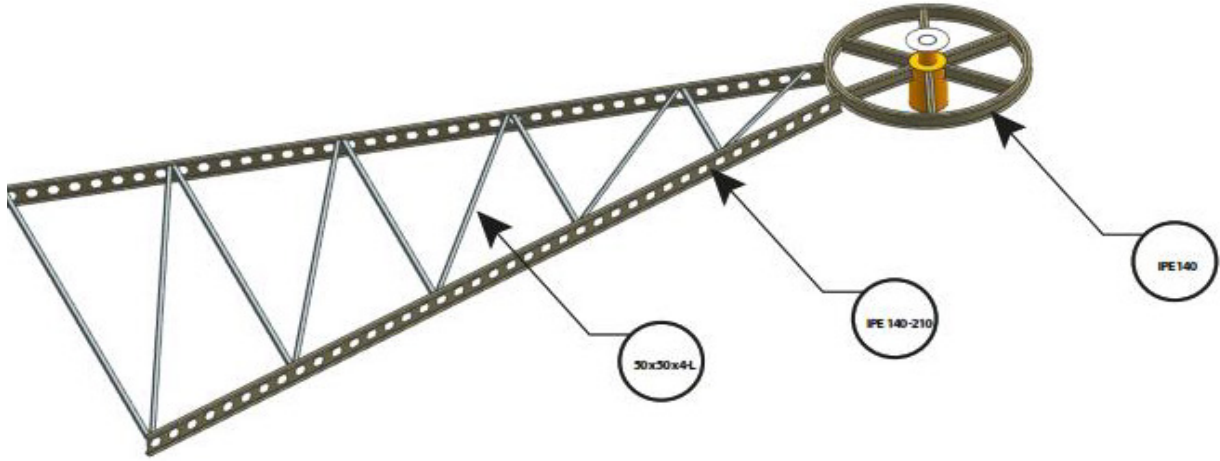

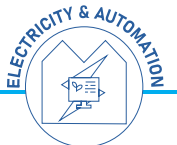
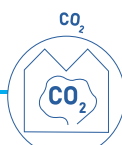
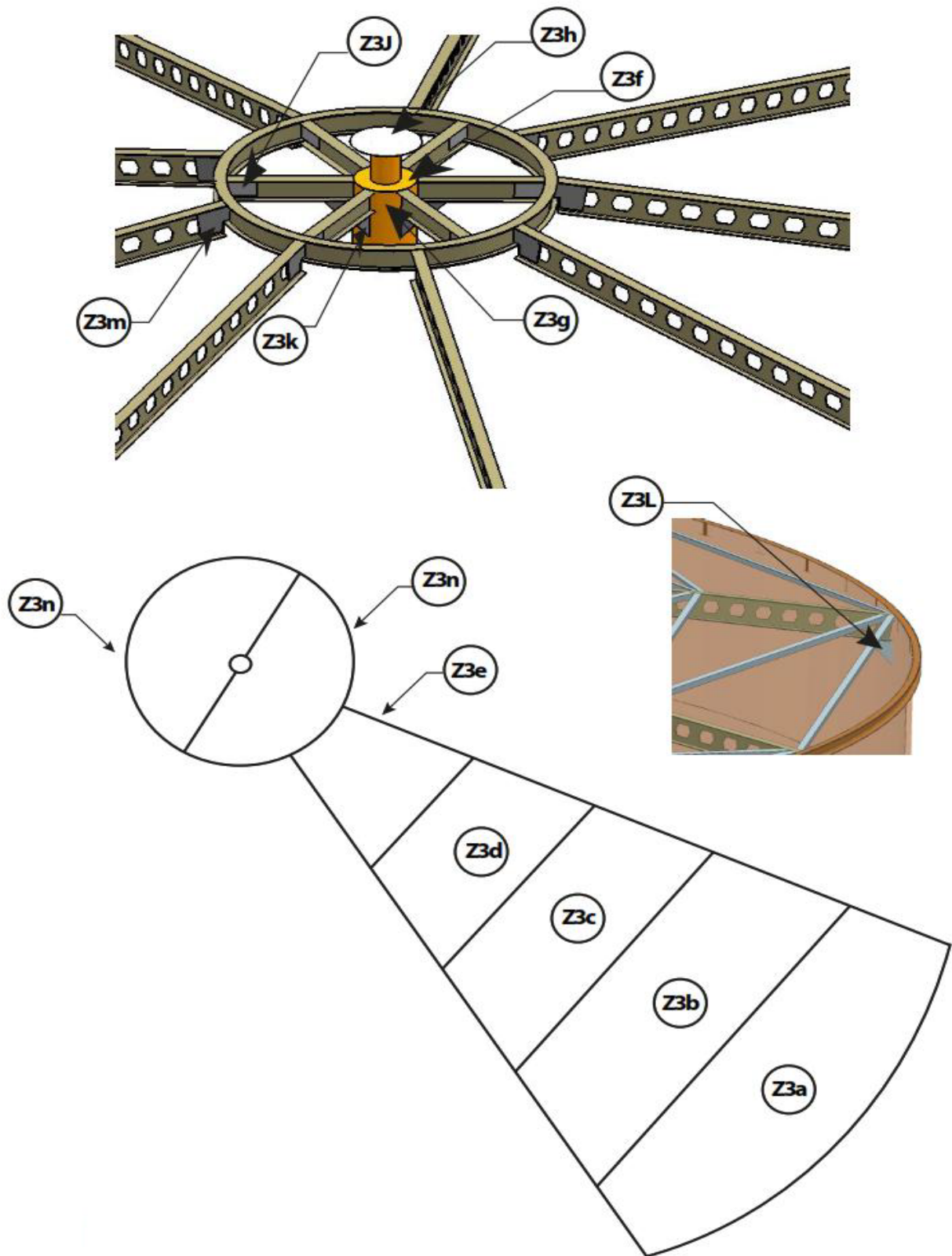

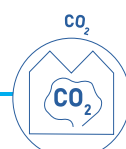
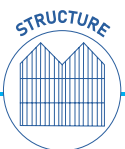
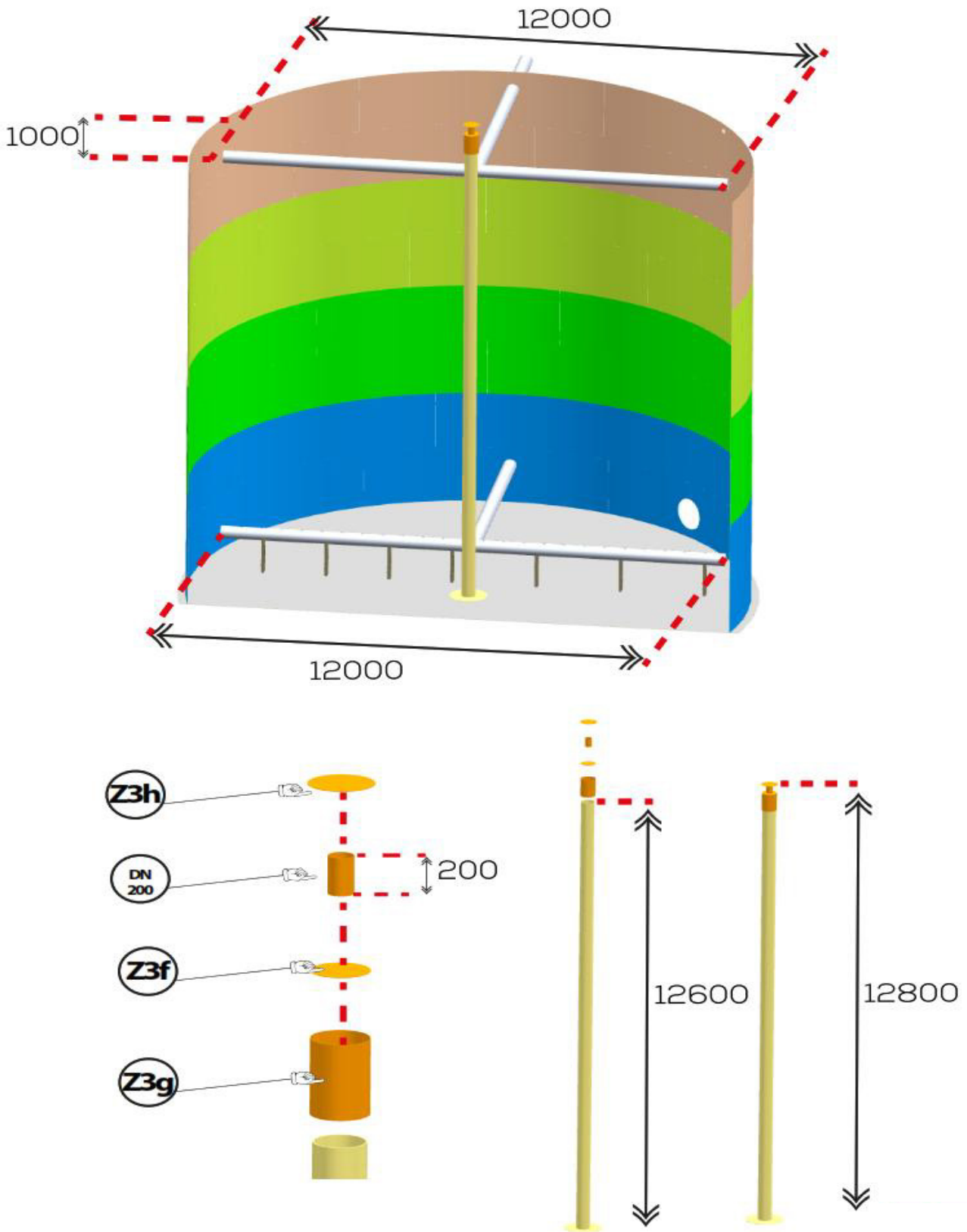

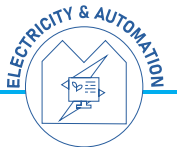
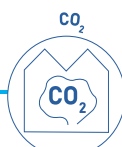
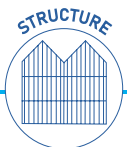
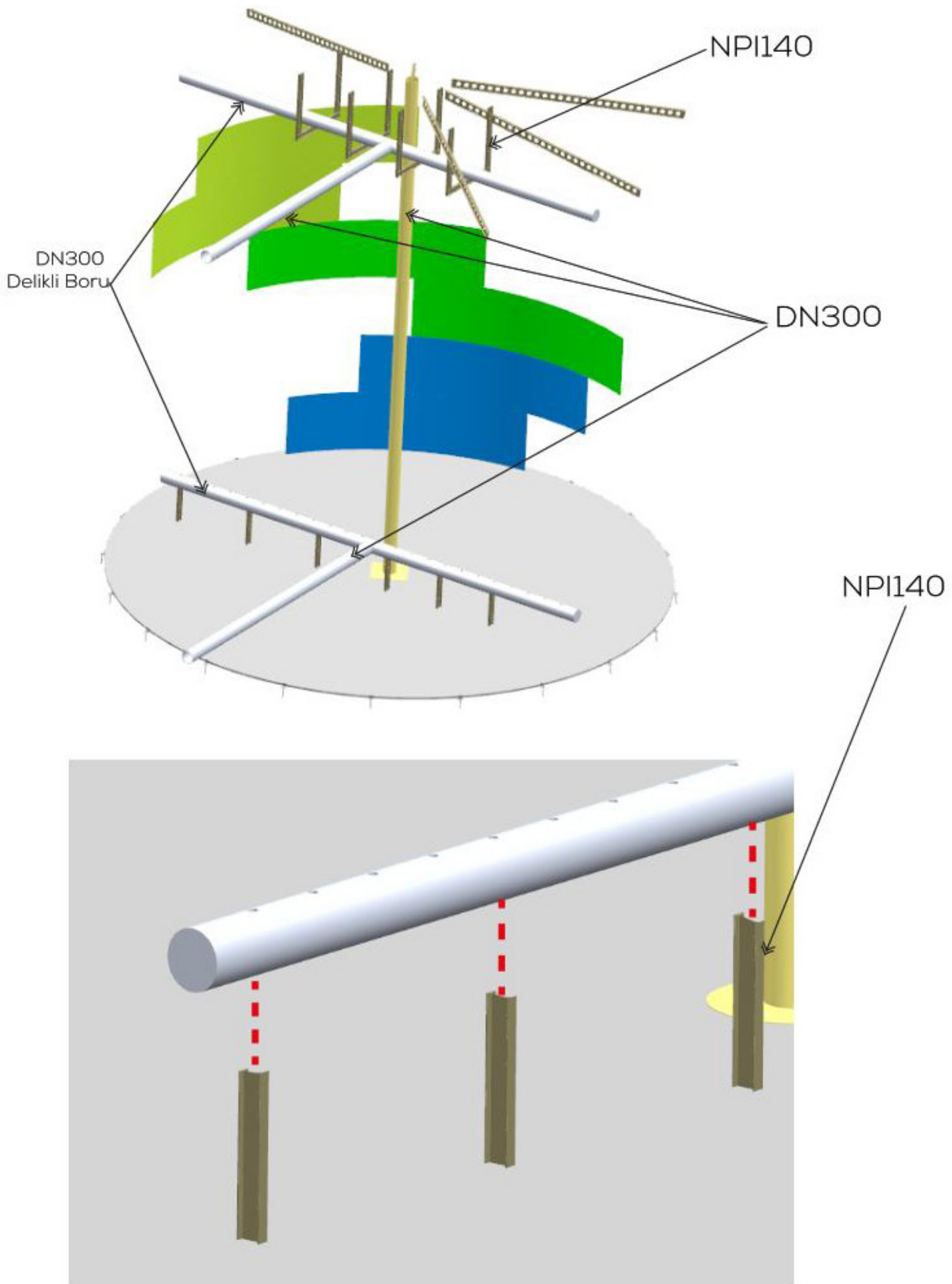

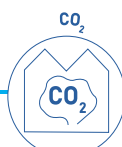
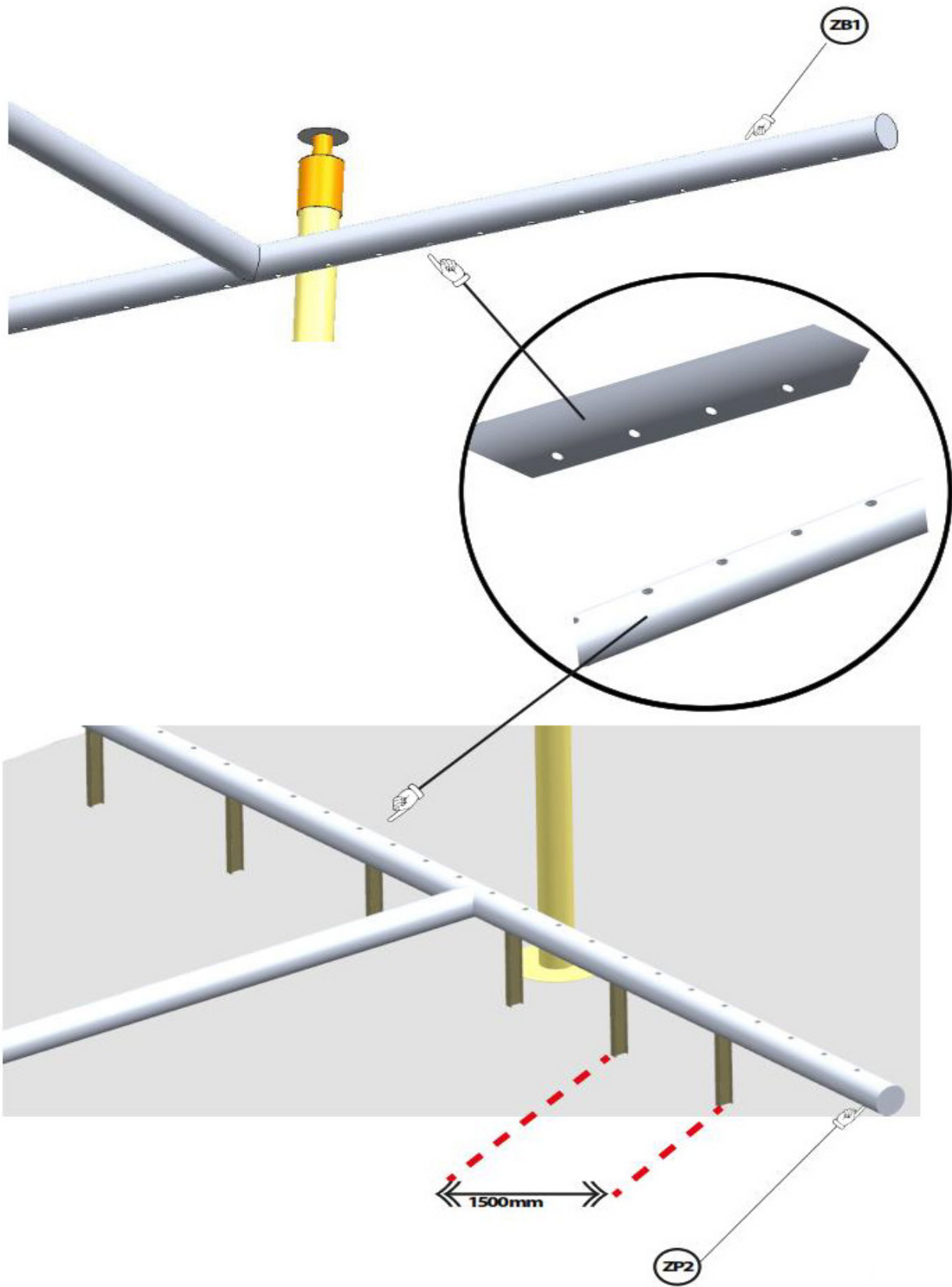

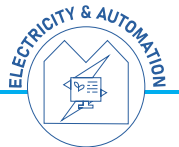
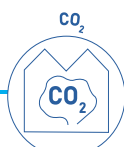
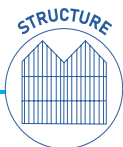
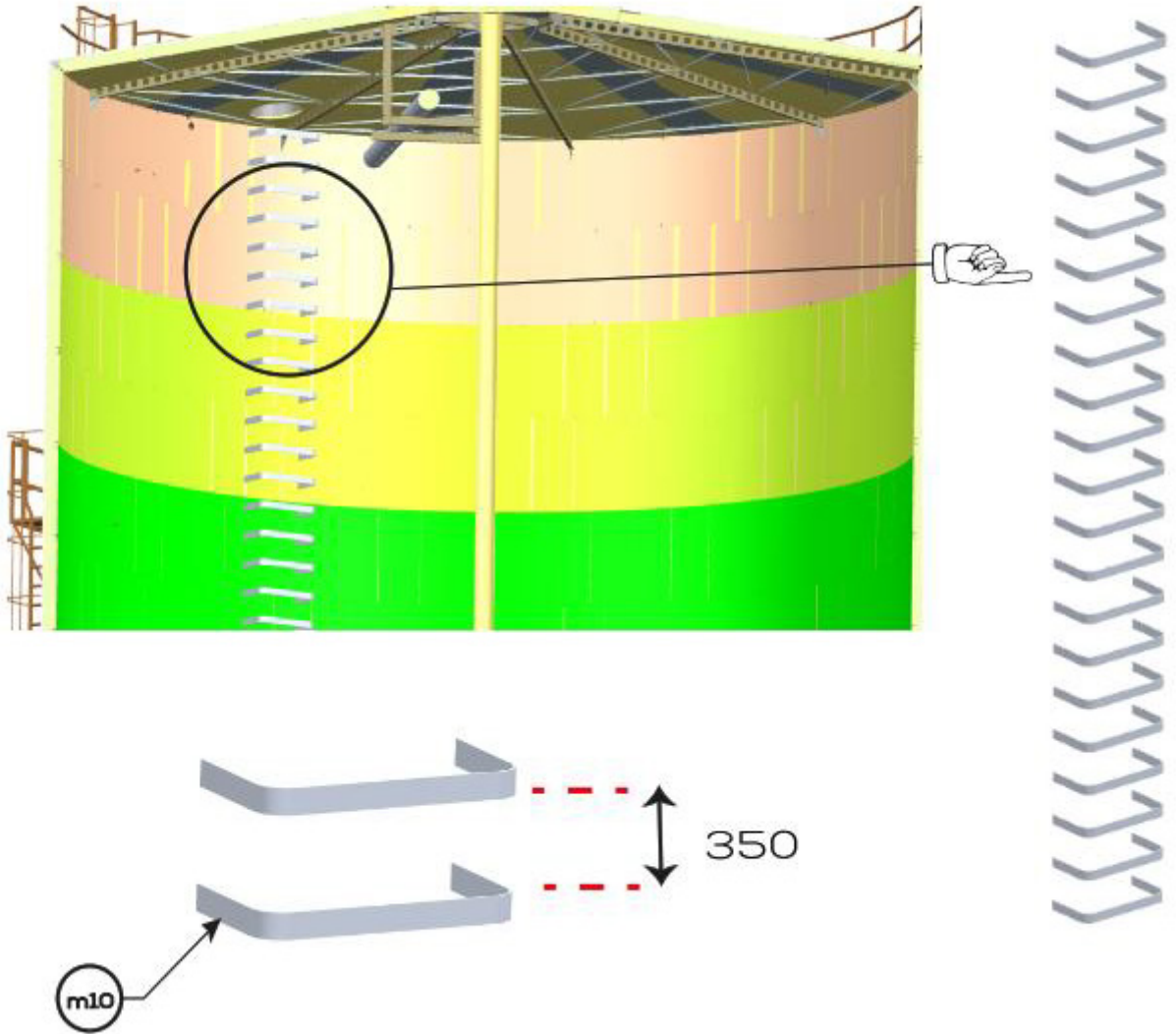

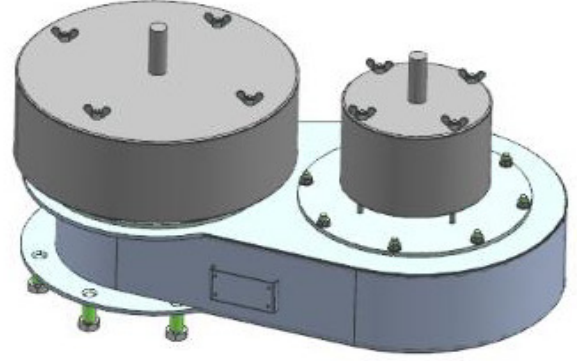
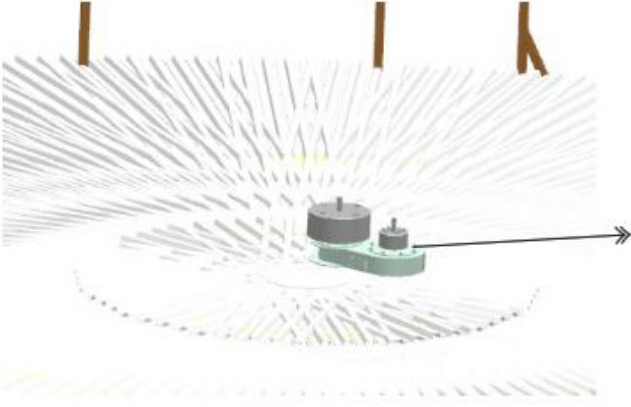

Prescon PV-200

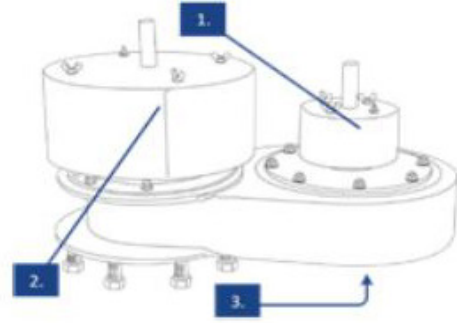
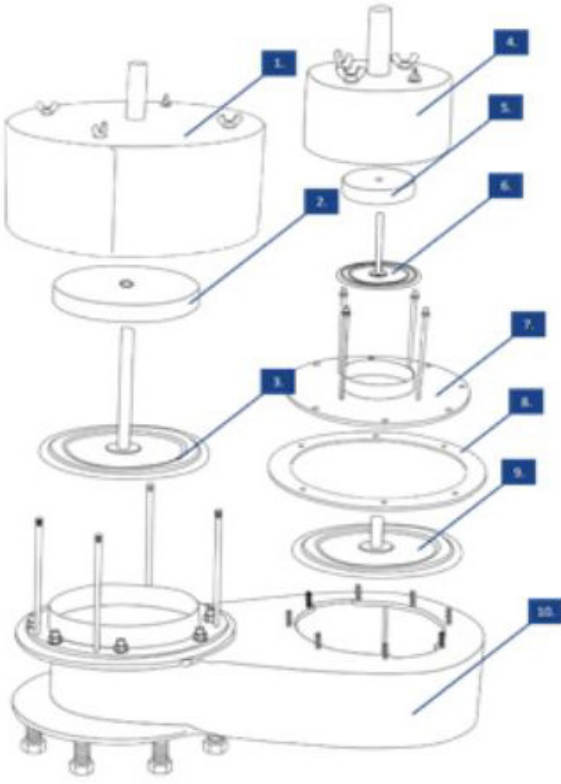

1. Aşırı basınç kapağı
2. Ağırlık
3. Vana
4. Çalışma basıncı kapağı
5. Çalışma basıncı ağırlığı
6. Çalışma basıncı vanası
7. Kapak plakası
8. Silikon conta
9. Vakum vanası
10. Güvenlik vanası gövdesi

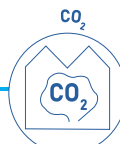

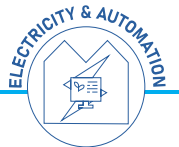
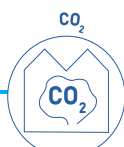
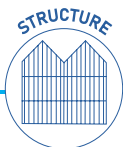
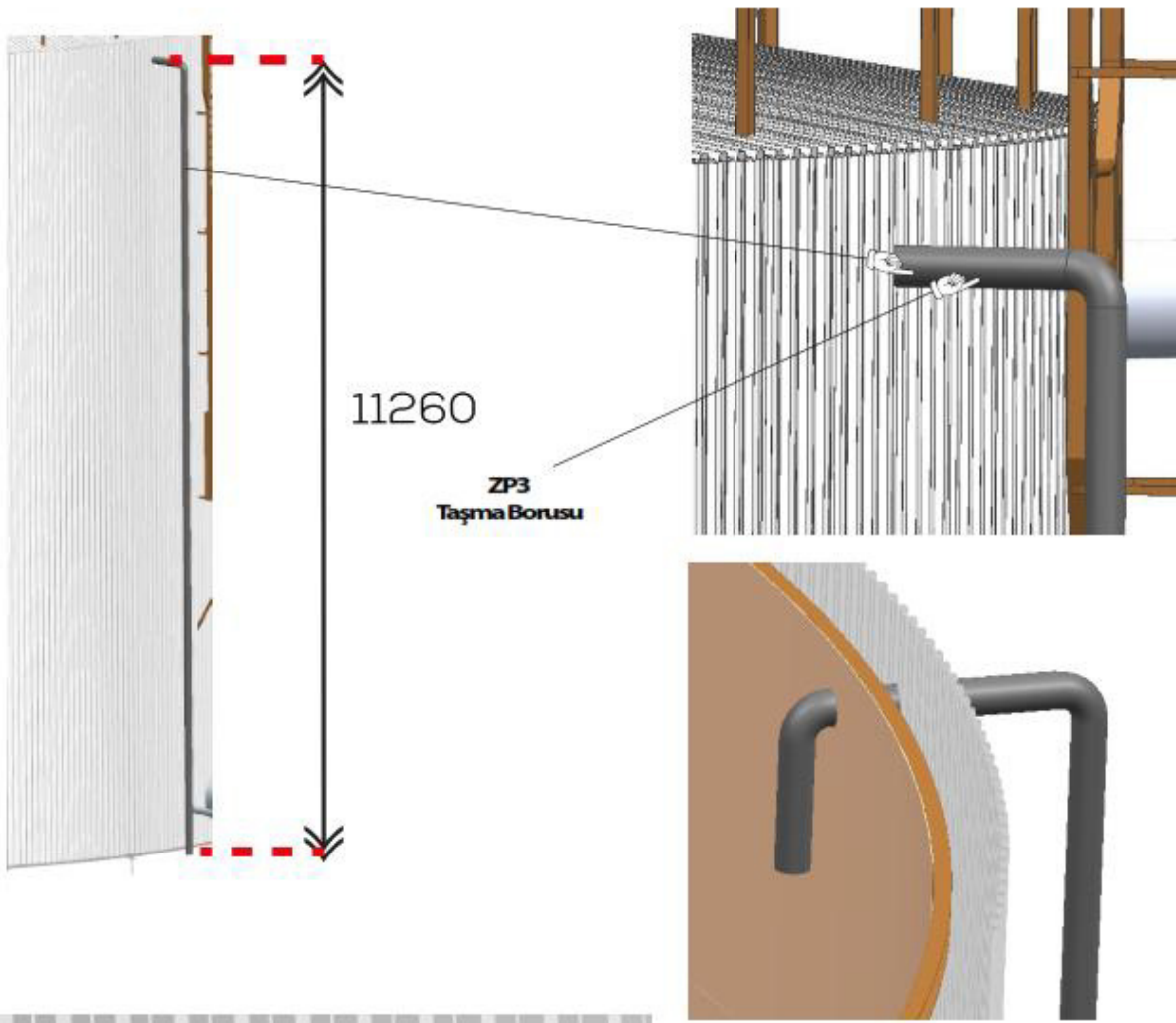

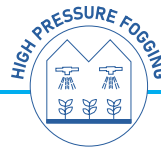
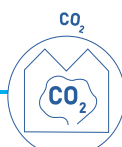
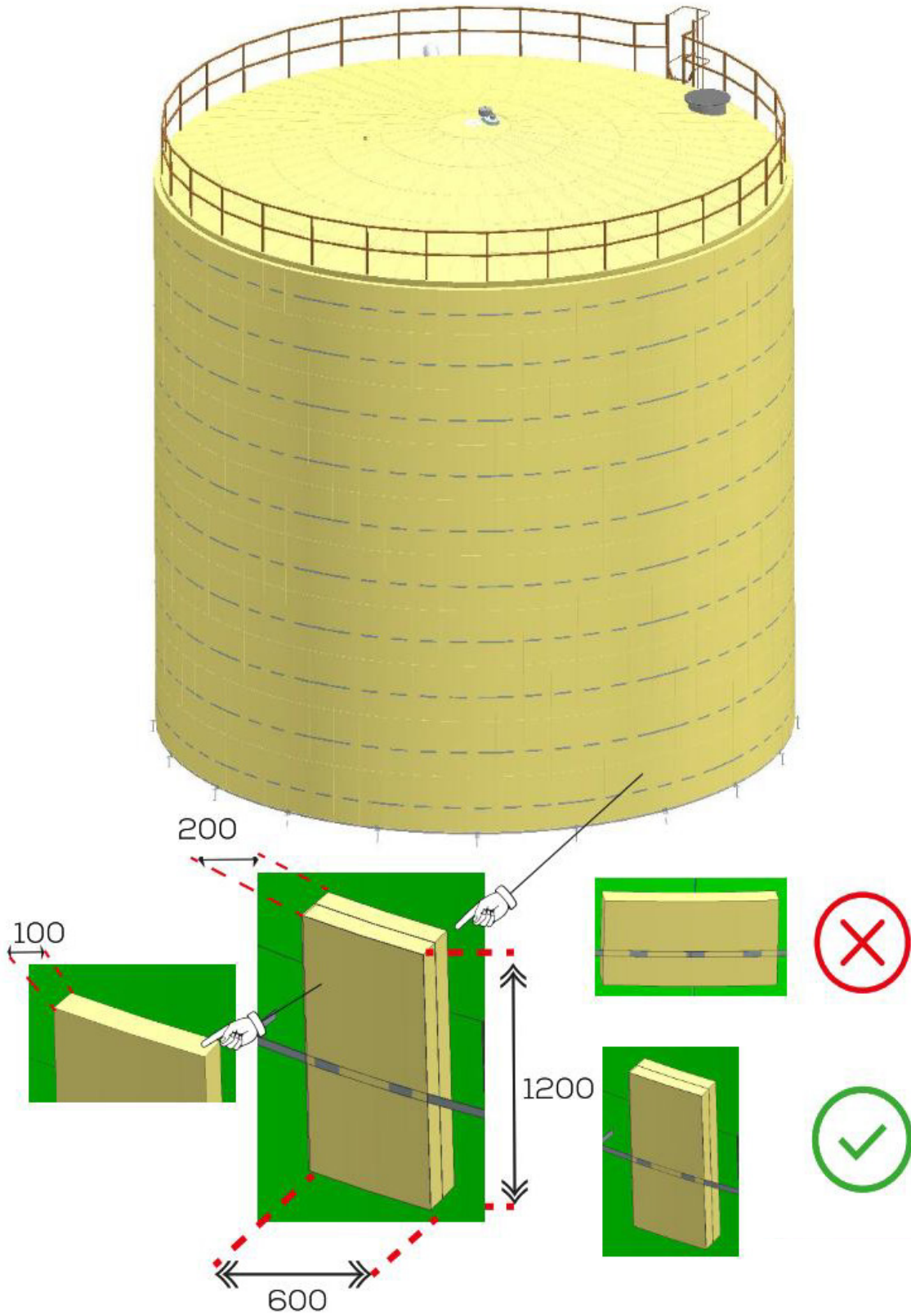

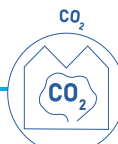
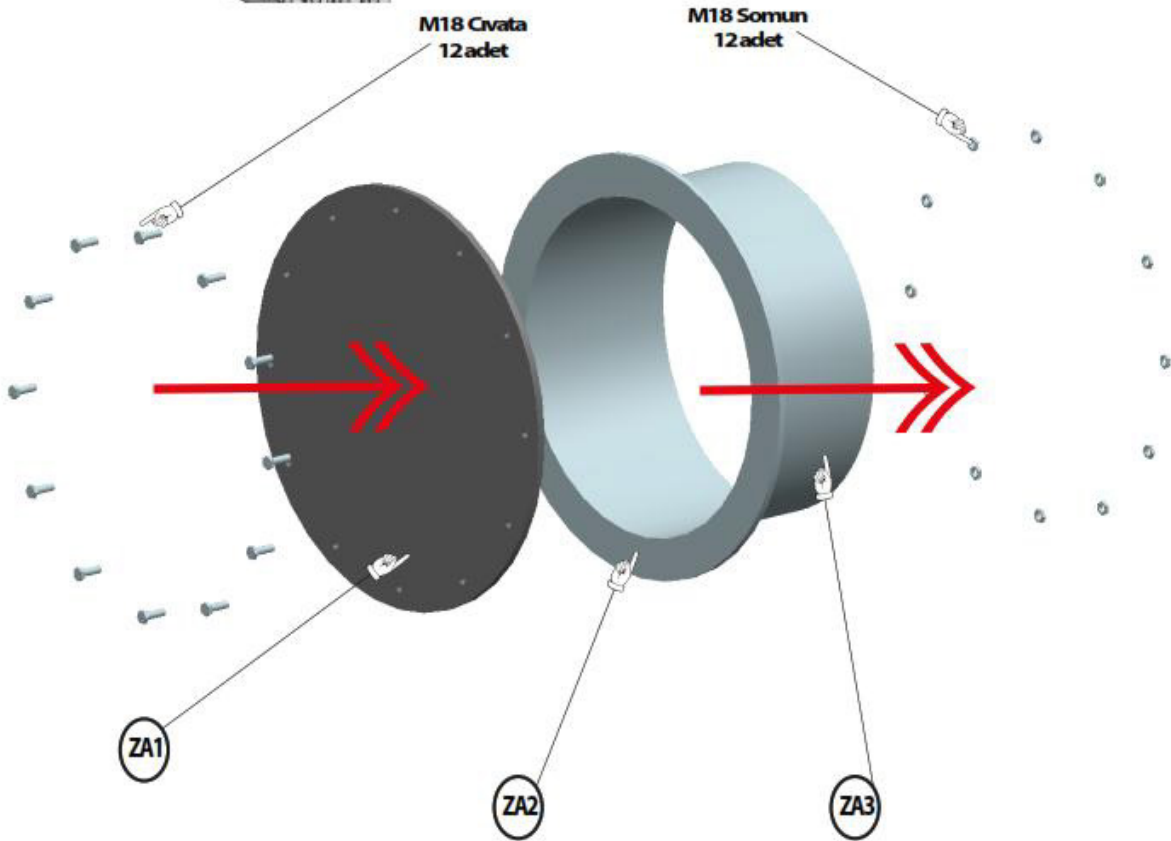
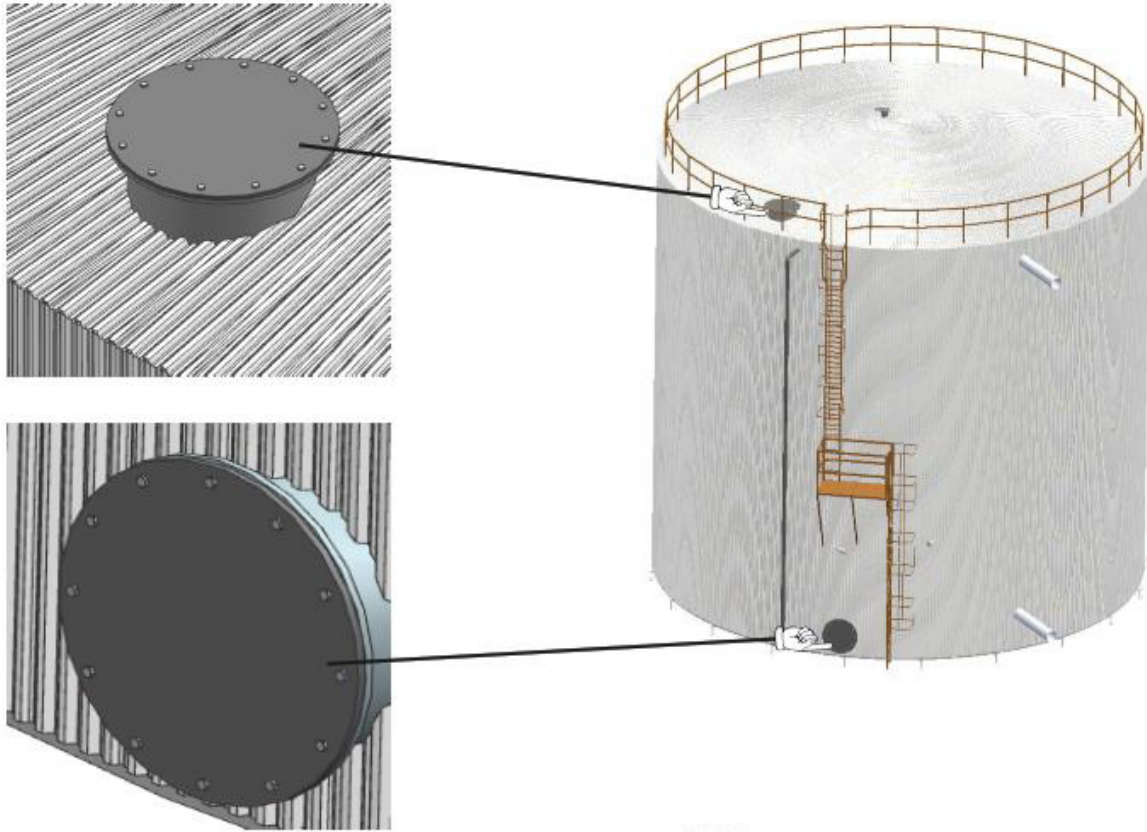

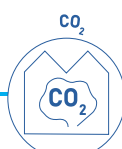
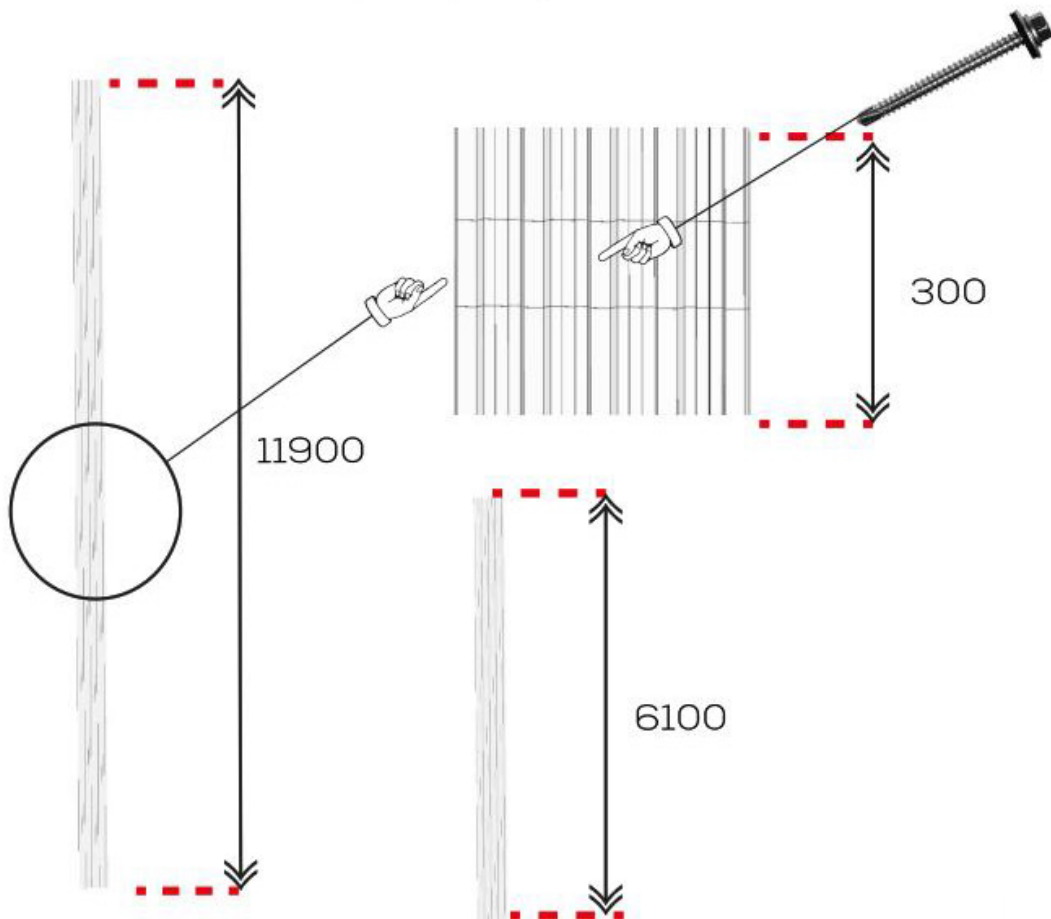

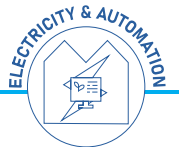
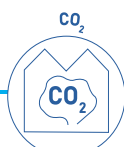
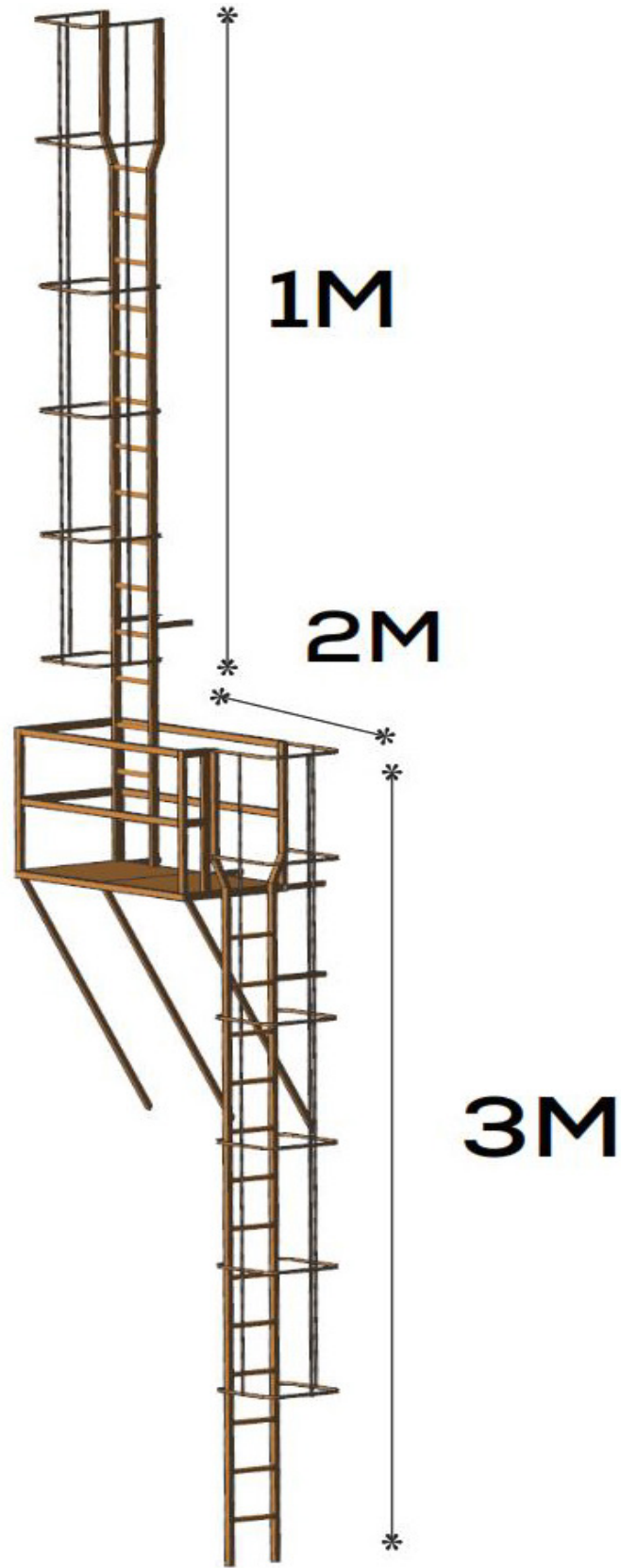

1M

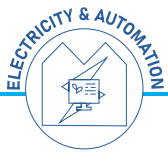
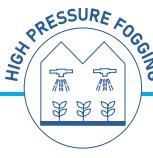
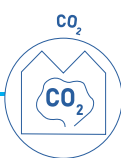
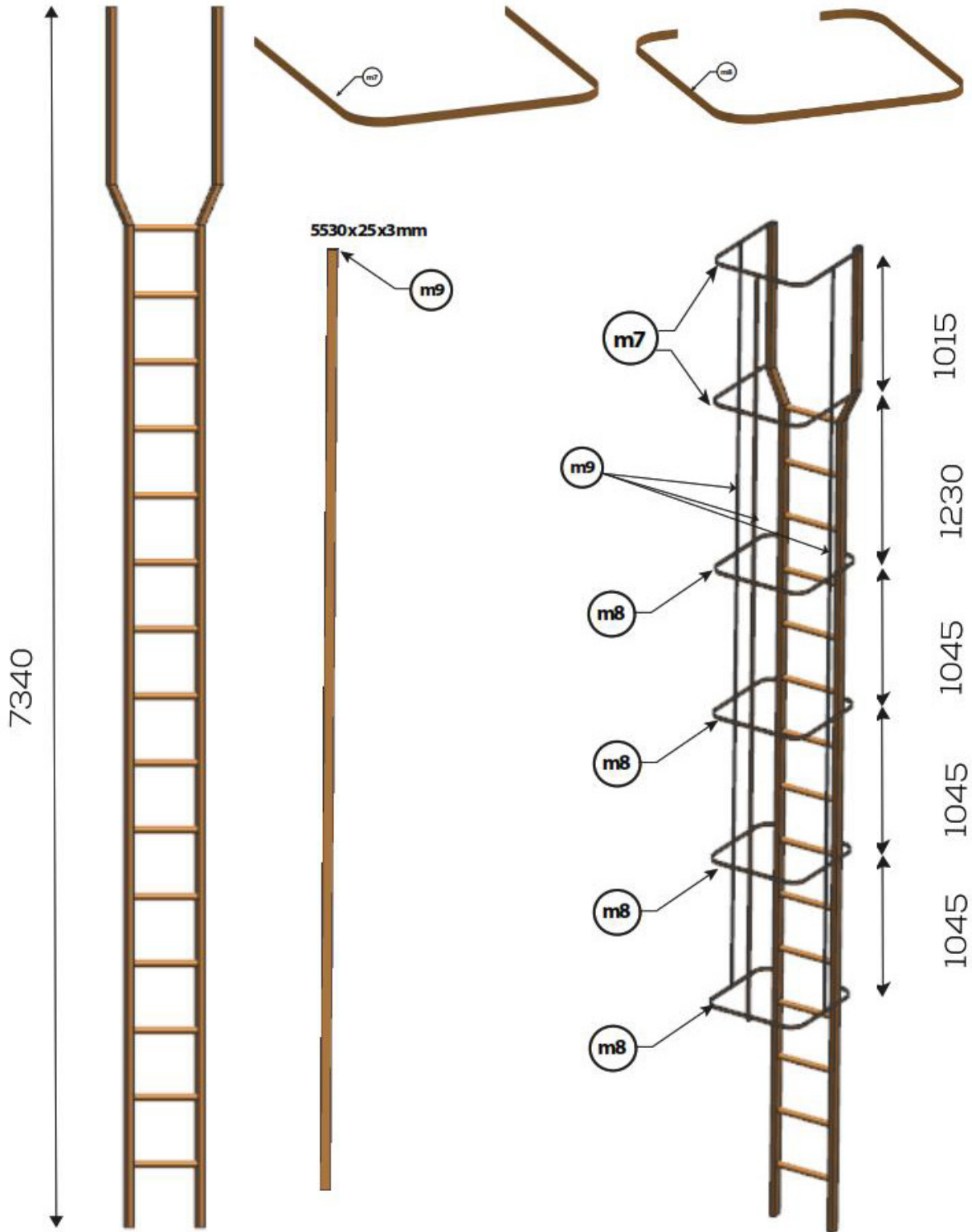

2M

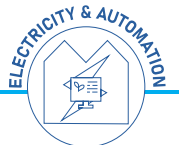
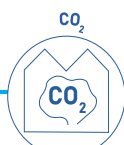
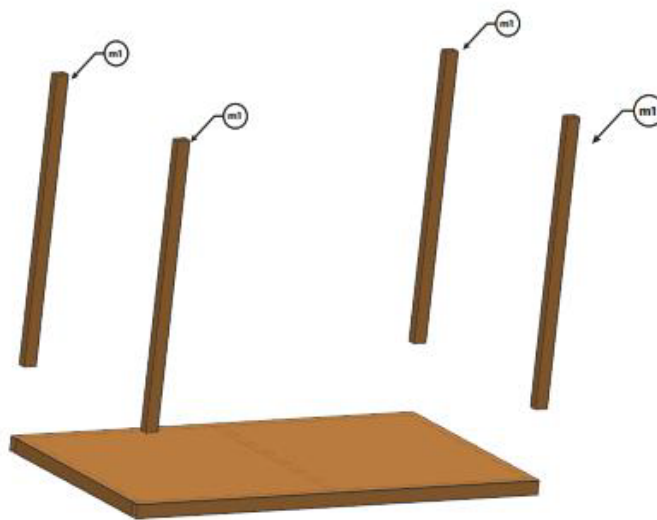
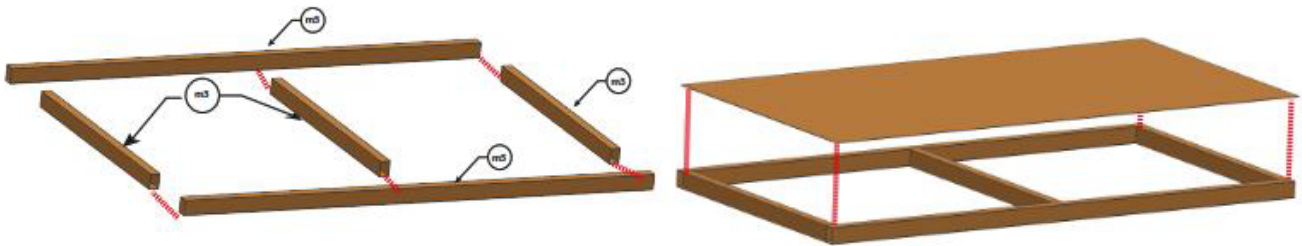
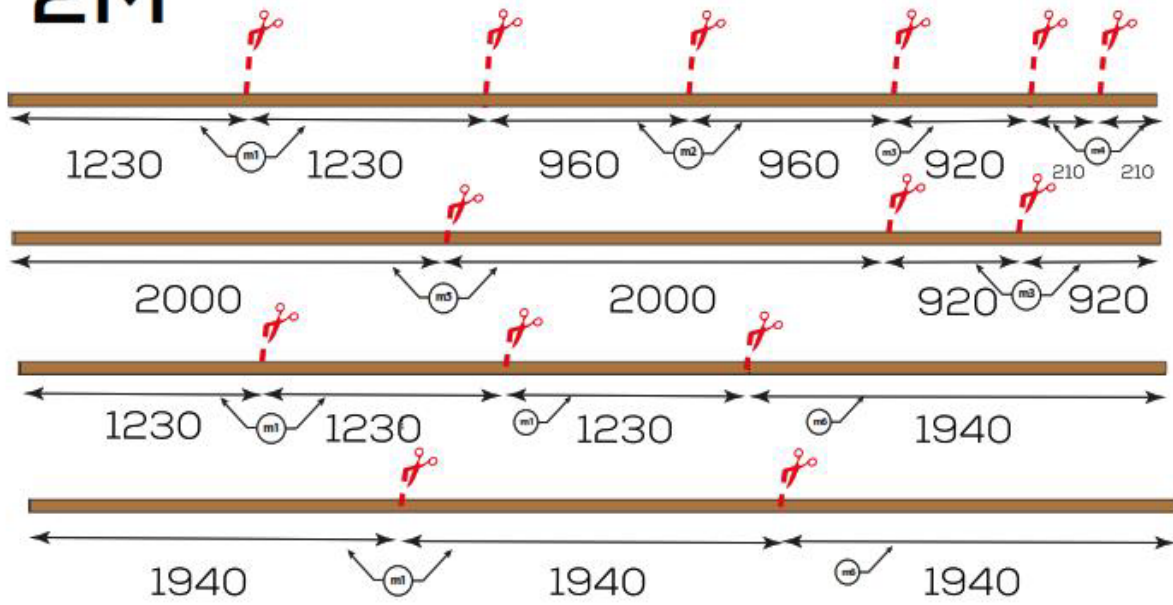

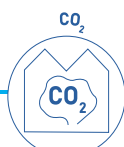
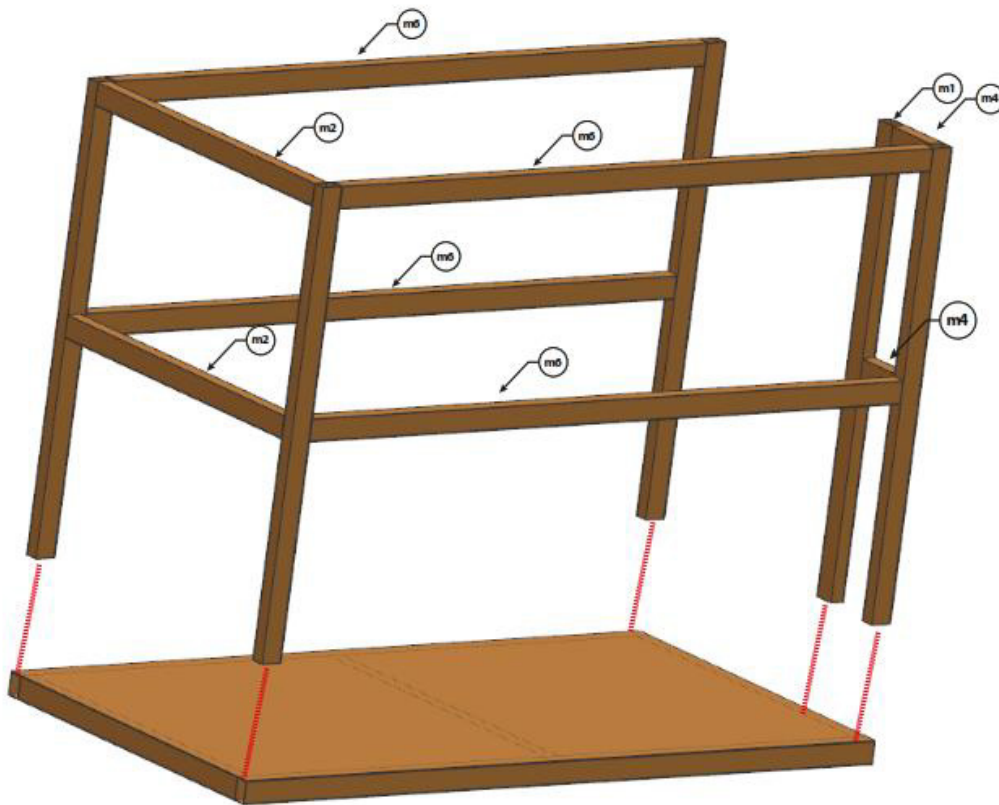

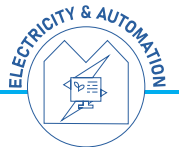
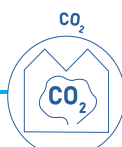
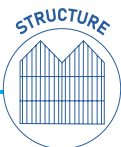
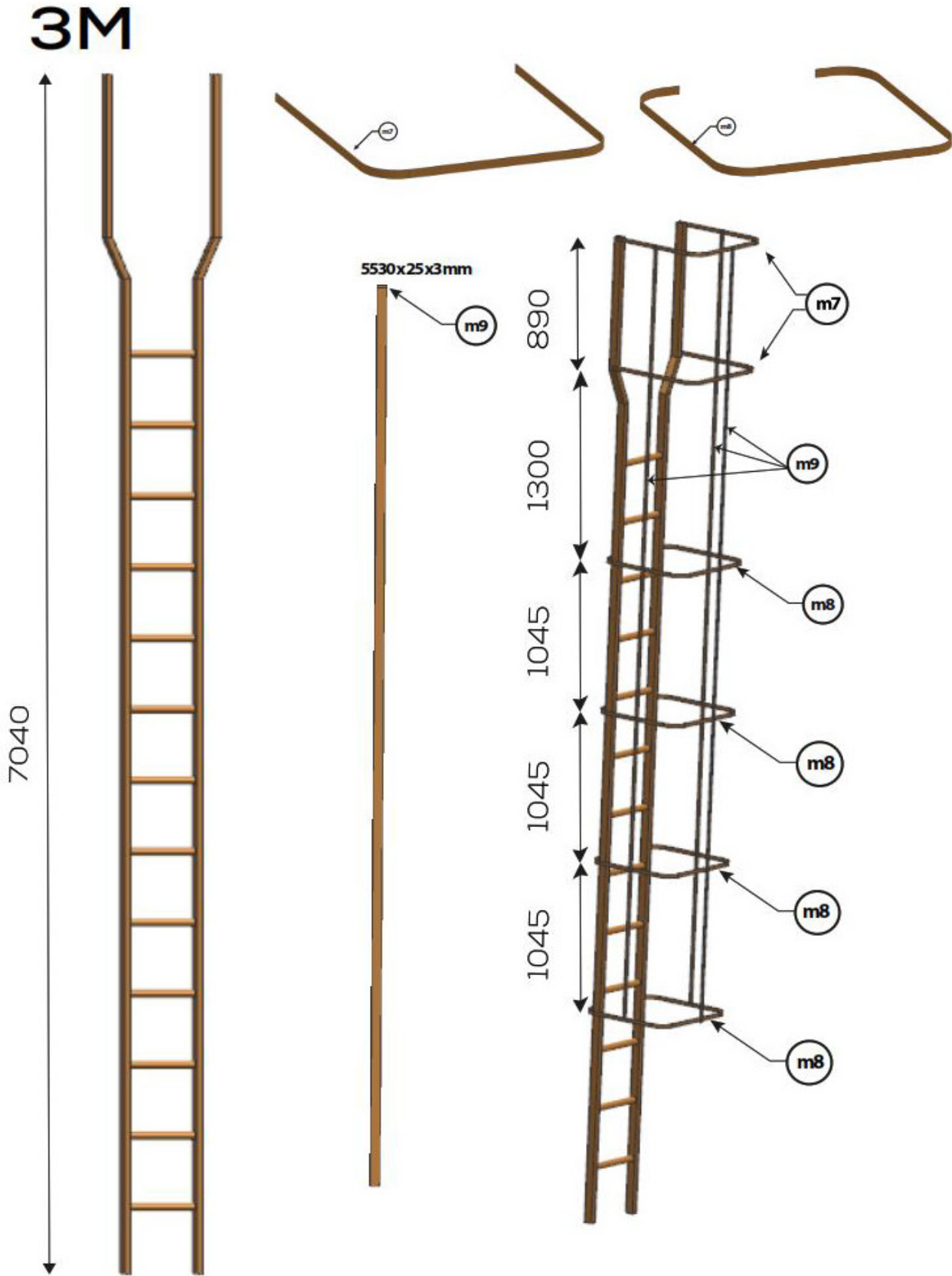

**Çerkeşli Osb Mah. İmes 7.Cadde
No:3 Dilovası/Kocaeli**

+90 262 244 44 94