

timfog



BUFFER TANK

USER MANUAL

BUFFER TANK

User Manual

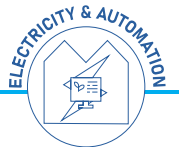
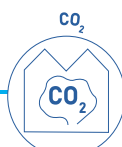
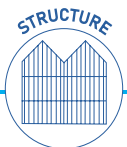

BUFFER TANK USER MANUAL



**SHIPMENT, STORAGE, INSTALLATION
MAINTENANCE AND USER MANUAL**

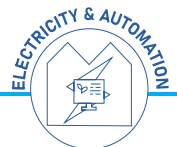
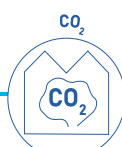

1. Introduction

1.1 Definition	3
----------------	---

2. Safety Instructions

2.1 General Hazards That May Occur If Safety Instructions Are Not Followed	4
2.2 Symbols Used in the Instructions	4
2.3 Transport and Placement	4
2.4 Working with Safety Awareness	5
2.5 Grounding Instructions	6
2.6 Specific Hazards	6
2.7 Adjustment and Assembly	6
2.8 Maintenance and Repair	7

3. Shipment, Handling, Placement and Storage

3.1 Information on Shipment, Handling and Placement	7
3.2 Regarding Storage	9

4. Technical Specifications

4.1 Assembly Instructions	9
4.2 Technical Details	18

5. Operation and Maintenance Instructions

5.1 Maintenance	20
-----------------	----

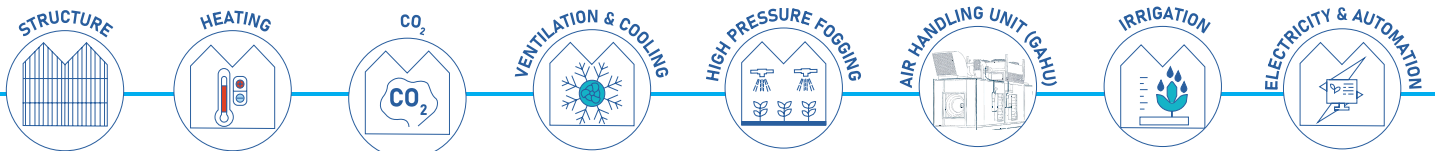

1. INTRODUCTION

First of all, thank you for choosing the TIMFOG Buffer Tank.

The operating safety of the TIMFOG Buffer Tank is entrusted to the operators who run the system.

This manual has been prepared to ensure safety and to keep the buffer tank in good working condition by informing users about the necessary precautions and rules.

Personnel authorized for the installation, commissioning, operation, maintenance, and repair of the buffer tank must read and understand this manual before starting work on the buffer tank.

This manual should be kept near the buffer tank in a safe and easily accessible place, away from direct sunlight or high temperatures.

The information in this book reflects the technology at the time of sale. If the product is later modified, this manual may no longer be valid.

The manufacturer reserves the right to update the buffer tank and this manual without prior notice and does not accept responsibility for outdated versions.



Before performing any of the following activities — installation, commissioning, operation, maintenance, or repair — make sure to read your “USER MANUAL”!

1.1 Definition

The main purpose of the buffer tank is to store the heat energy generated in boilers during CO₂ supply to greenhouses during the day. This stored energy reduces boiler water temperature and enables the reuse of hot flue gas, first circulated through condenser coils to lower its temperature. As a result, the cooled flue gas and the CO₂ within it become ready for use in greenhouses. The flue gas and CO₂ temperature are also balanced via a 3-way mixing damper, allowing the air from the boiler room to be mixed and used safely in the greenhouses.

The second purpose of the buffer tank is to serve as an auxiliary energy source when the primary energy feeding the heat exchangers is interrupted for maintenance, renewal, or cleaning. If one of the exchangers or both are out of service, or if the flue gas temperature drops below a designed threshold, the buffer tank provides backup energy.

The heat stored in the buffer tank, which is heated by boilers or exchangers, can be used in greenhouses as a supplementary energy source. When required, only the energy from the buffer tank can be utilized.

The advantages of buffer tanks produced by Timfog are as follows:

- All tank sheet metal and construction designs are created by Timfog engineers. During the design process, pressure and strength tests are performed in a computer-aided environment before manufacturing.
- All necessary assembly and installation details are shared with the customer.
- Timfog buffer tanks are manufactured using high-quality materials. (Including manhole, roof hole, discharge valves, internal/external ladders, filling systems, transport valves, and roof safety rails.)

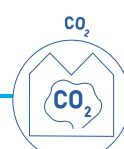
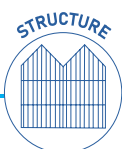

2. Safety Instruction

2.1 General Hazards That May Occur If the Safety Instruction Is Not Followed

In order to operate the Buffer Tank safely, the necessary safety precautions to be followed are included under the heading “Safety Instruction” in this section.

Before starting to operate the machine, this “Safety Instruction” must be read carefully and fully understood. TIMFOG Buffer Tanks are manufactured in compliance with the latest technological standards and occupational safety requirements.

However, persons who have not been informed or at least warned may cause danger when using the device.

- Damage that may occur to the bodies or lives of Buffer Tank operators, users, or third parties.
- Damage that may occur to other objects or equipment due to the Buffer Tank or the operator.

2.2 Symbols Used in the Instruction



Indicates a warning sign against the possibility of entering a dangerous area and personal injury.



Indicates a warning sign against hazards related to electricity.



Indicates a warning sign against rotating and moving parts.



Indicates that special attention must be paid to instructions, precautions, and recommendations.

2.3 Transport and Placement

Information and warnings required for the transport and placement of the tank components are presented to the user in this manual.

The transport dimensions and weights of the tank components are specified in the packaging list.

When receiving the tank components, compare them with the package list and perform damage inspection.

Use a forklift or a mobile crane to unload the parts. Use portable equipment (such as transpallet or manlift) for moving the materials to their locations.

Avoid any conditions that may pose danger during the relocation of heavy parts.

Ensure that the tank components are stored in safe places.

Secure the storage area of the materials to prevent possible injuries.

If materials are stored outdoors, take protective measures to shield them from environmental conditions.

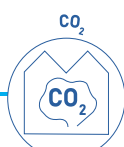
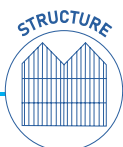

Ensure that parts containing electrical components are stored in closed and low-humidity environments to prevent deterioration.

Materials are specially packaged and counted before being shipped to the construction site; be careful to prevent package scattering during transportation.

It is not necessary to wear protective clothing or masks when transporting insulation materials. When transporting sharp or pointed materials, protective gloves and a helmet must be worn. Always maintain eye contact with the operator while using transport equipment in the work area.

Avoid sudden movements.



2.4 Working with Safety Awareness

Before starting tank assembly, the area where the tank will be placed must be completely cleared of foreign materials.

All elements that may endanger the health of workers in the working area must be removed.

Ensure that all equipment used during work has undergone periodic maintenance and does not pose any danger.

When working with electrical equipment, make sure that power is disconnected and that power cables are not short-circuited.

Ensure that necessary precautions are taken when using electrical tools.

Be mindful of weather conditions when using electrical equipment.

When handling electrical components, use insulated cables in accordance with international standards.

Ensure that the required safety measures are taken when using rotating machinery.

Be cautious around areas where rotating parts are located.

Use appropriate safety equipment to protect yourself from metal burrs or sparks that may occur while grinding.

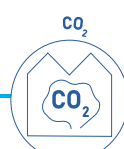

Use the necessary safety equipment to prevent possible injuries during welding.
 Be cautious of hot surfaces.
 Be careful around sharp edges of newly cut areas.
 Be cautious of the heat around newly welded points.
 Always use your safety equipment when working at height.
 Ensure that the tools and equipment used while working at height are in safe condition.
 Be careful to prevent falls from height, and use your safety equipment.
 On wet or slippery ground, walk carefully and take precautions against the risk of slipping.
 Be cautious of sharp or piercing materials that may appear during installation or be present in the surroundings.
 When handling or assembling materials with chemical compositions, always use protective safety equipment.
 Stay away from situations that threaten occupational safety.
 In case of an accident, immediately inform the nearest occupational safety specialist.

2.5 Grounding Instructions



Before using any electrical equipment, ensure that it is properly connected to a grounding line.
 Electrical panels without grounding must not be used.
 To prevent electric shock or short circuits, verify the existence and integrity of grounding connections before use.
 Electrical tools that are not grounded must not be used.

2.6 Special Hazards

**SAFETY DEVICES MUST NEVER BE DISABLED UNDER ANY CIRCUMSTANCES.
 IT IS STRICTLY FORBIDDEN FOR UNAUTHORIZED PERSONNEL TO MAKE ANY MODIFICATIONS TO THE TANK.**

Before using the tank, make sure that all inspections have been completed.
 Ensure that all safety equipment is connected and functional before operating the tank.
 Check the valve conditions before starting the tank filling process.
 During filling, ensure that the vent hole and overflow valve at the top are open.
 During draining, ensure that the vent hole and overflow valve at the top are open.
 Ensure that all equipment on and around the tank undergoes regular maintenance.

2.7 Adjustment and Installation

-  Adjustment and installation operations must be performed by authorized personnel and in accordance with the instructions in this manual.
 Otherwise, there is a **RISK OF FATAL INJURY!**
-  If any adjustment is to be made, it must be performed by authorized and properly informed personnel.
-  The air conditioning control panel must not, under any circumstances, be installed or interfered with outside the designated working area.

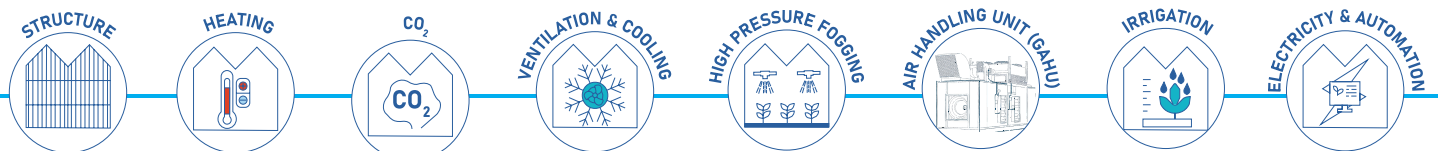

2.8 Maintenance and Repair



Maintenance and repair work must only be carried out by trained and authorized personnel. Service operations must always be performed by an authorized service provider!



For maintenance and repair operations, the air handling unit must be stopped, the main switch must be turned off and locked, and the key must be removed.

At the same time, to prevent the air handling unit from being operated during maintenance, a “UNDER MAINTENANCE” warning sign must be placed on the electrical panel.



After maintenance and repair work, the system user must check the operational safety status and safety devices of the system again.

If it is necessary to remove certain parts during repair, appropriate safety precautions must be taken.

Periodic maintenance of the system must be performed as described in this manual.

The “Safety Instruction” is valid only in Turkish.

Shipment, Transport, Placement, and Storage

3.1 Information on Shipment, Transport, and Placement

The parts of the Buffer Tank are shipped by distributing them onto trucks according to their capacities and dimensions.

The materials to be loaded onto each truck are determined in advance.

To ensure safe transportation of materials, the transport vehicle to be used must have sufficient load capacity, and the length, width, and height of its cargo space must be suitable for the materials to be transported. If needed, you can request a vehicle loading plan from TIMFOG.

When determining the transport vehicle, consider whether it can maneuver in the unloading area and whether unloading from the truck is possible.



No one should stand under a suspended load during the unloading or placement of materials from the transport vehicle!

Ensure that the materials arriving at the worksite are transported under proper conditions, protected from weather conditions, and not damaged during transport.

After the materials arrive at your facility, do not sign the delivery note before inspecting the materials. If you notice any damage, record it in writing on the delivery note and, to enable a quick insurance claim, send a short certified letter describing the damage to the transport company responsible and, if applicable, the insurance company.

Inform TIMFOG about this situation as well.

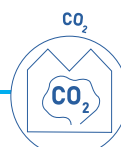

In case of any malfunction, take photographs of the materials before unloading them from the vehicle, prepare a damage report, and have it signed by the driver.

Ensure that the materials are secured to the transport vehicle with thick ropes or straps.

For large materials, make sure the base is securely fixed to the vehicle bed.

Steel ropes must not be used for connecting or transporting equipment!

When loading materials onto a crane, winch, or truck, ensure that the load is evenly distributed and properly balanced.

To prevent damage during unloading and transportation, use lifting slings or chains connected at four corners of the crate or beam.

Do not place any devices on top of each other during shipment, transportation, or storage.

Materials must be protected under all weather conditions; during shipment, cover them with a tarp.

Devices must be stored in enclosed spaces.

During lifting and handling, materials must not be tilted or overturned.

Be cautious and take necessary precautions to prevent strong impacts during lifting and placement of materials.

When unloading units from the truck with a forklift, ensure that the load is evenly distributed across the forklift forks and that the forks do not hit the panels.



Light materials can be carried manually as shown in the illustration.



A crane must be used for transportation and installation operations.

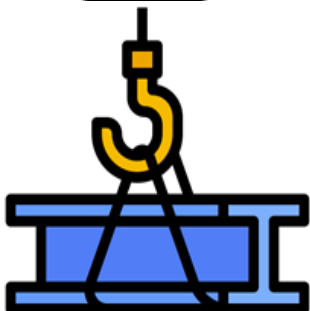

Profiles must be connected in this manner during the assembly phase.



WARNING! All safety warnings, occupational health and safety rules, and legal regulations stated in this manual must be followed during loading and unloading operations!

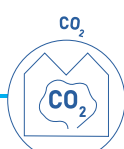
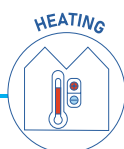
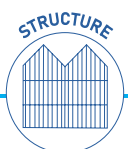

3.2 Information on Storage

The materials should be placed on wooden blocks in the construction site storage area, and in the installation area, the device should be positioned on a base suitable for its weight.

4.1 Montaj Talimatları

Before starting the installation, make sure that all necessary equipment is available on site and in safe working condition.

After determining the location of the tank, reference points are marked from the central point according to the required measurements.

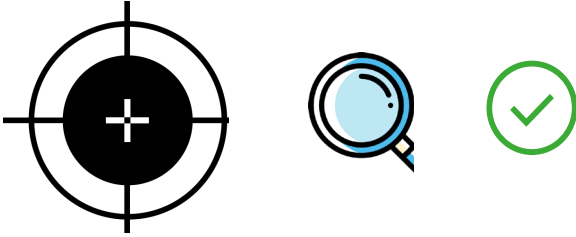

The ring that will protect the insulation under the tank is placed first.

After placing the ring, the installation of the XPS insulation begins.

Once the insulation is installed, an oily sand layer is applied on top.

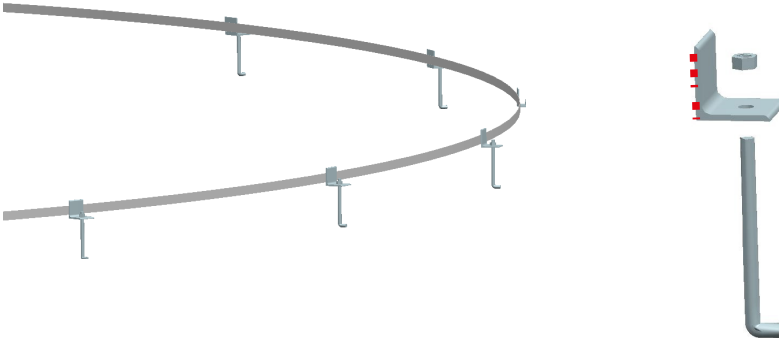

XPS insulation and oily sand

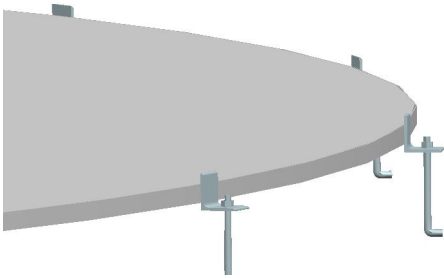

STRUCTURE



HEATING



CO₂



VENTILATION & COOLING



HIGH PRESSURE FOGGING



AIR HANDLING UNIT (AHU)



IRRIGATION



ELECTRICITY & AUTOMATION



After spreading the oily sand, the bottom plates are placed. When positioning the bottom plates, pay attention to the numbering shown in the drawing.

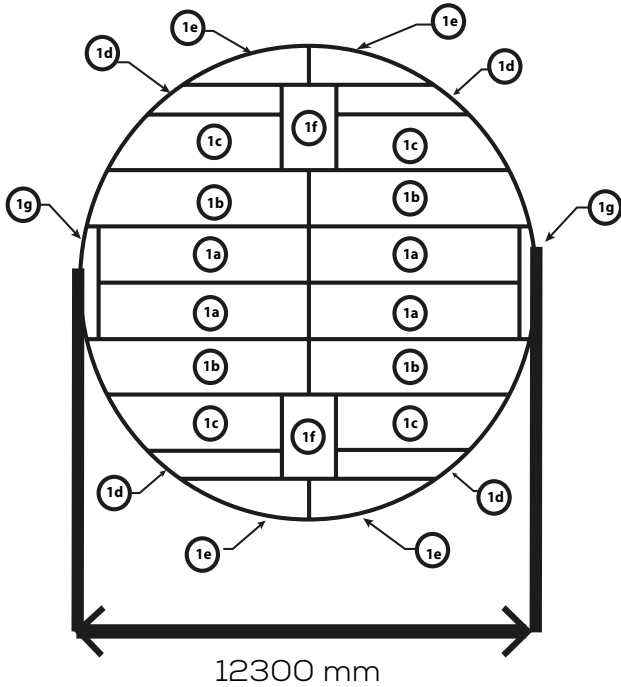

1250 TONS

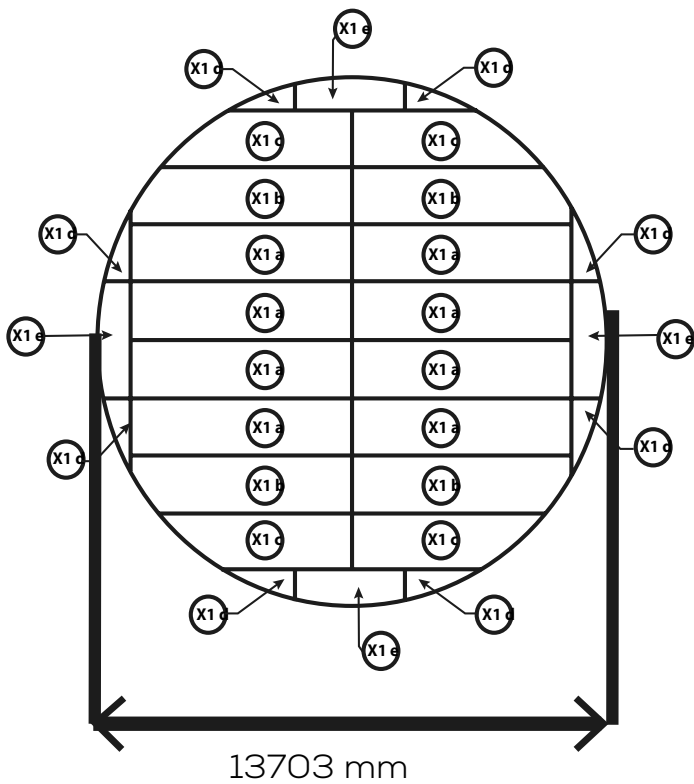

1500 TONS

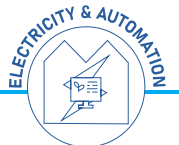
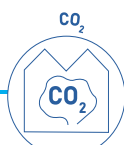

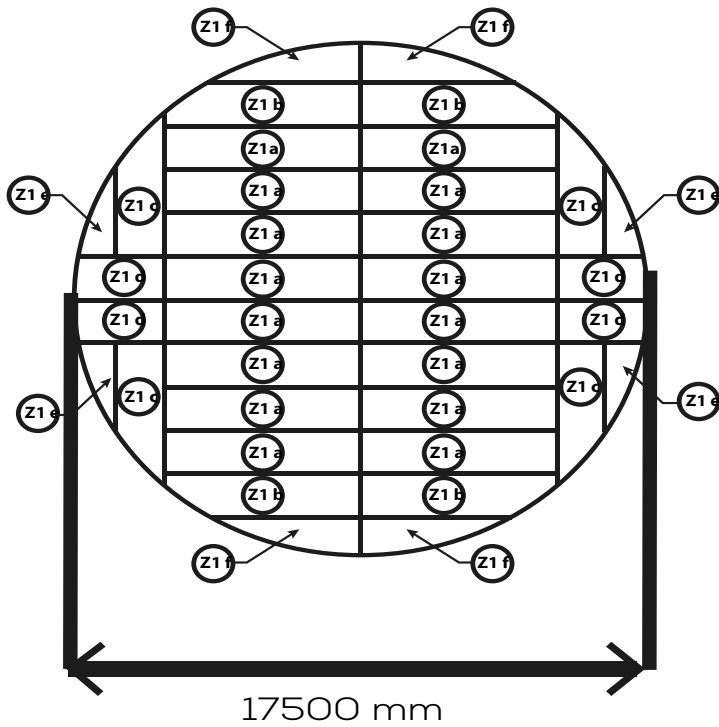

2500 TONS

After the welding of the bottom plates is completed, the installation of the wall plates begins. After the installation of two rows of wall plates, U-profile support rings are placed.

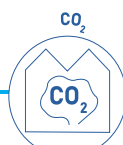
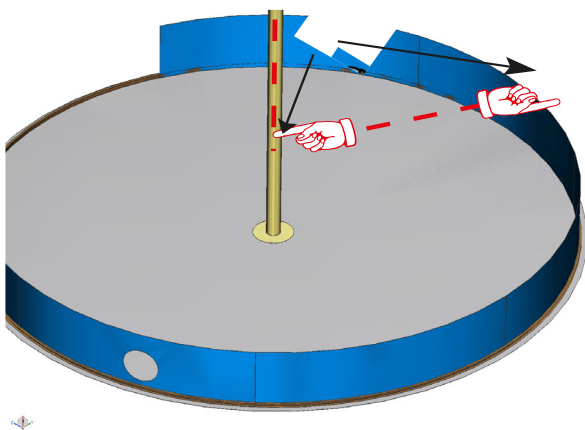

Recommended Welding Method:

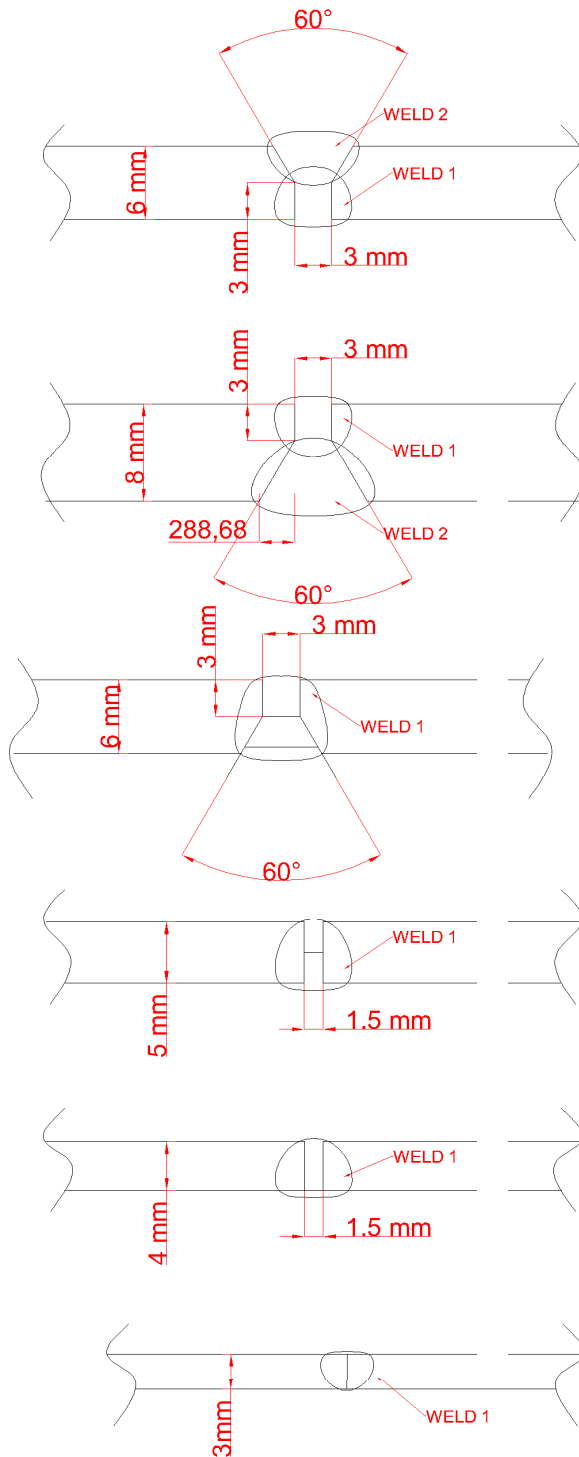

BOTTOM PLATE WELDING

Weld Groove: Top side
 Welding: weld 1 = 4 mm – 130A
 weld 2 = 5 mm – 170A
 Welding Speed: 5 m/h

WALL PLATE WELDING

Weld Groove: Outside
 Welding Direction: Bottom to top
 Welding: weld 1 = 4 mm – 130A
 weld 2 = 4 mm – 180A
 Welding Speed: 3 m/h

WALL PLATE WELDING

Weld Groove: Outside
 Welding Direction: Bottom to top
 Welding: weld 1 = 3.25 mm – 110A
 Welding Speed: 4.6 m/h

WALL PLATE WELDING

Weld Groove: None
 Welding Direction: Bottom to top
 Welding: weld 1 = 3.25 mm – 110A
 Welding Speed: 6 m/h

WALL PLATE WELDING

Weld Groove: None
 Welding Direction: Bottom to top
 Welding: weld 1 = 4 mm – 120A
 Welding Speed: 20 m/h

TOP PLATE WELDING

Weld Groove: None
 Welding Direction: weld 1 = 4 mm – 115A
 Welding Speed: 27 m/h

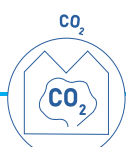
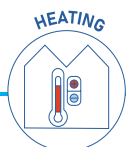
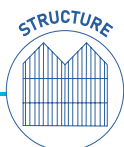

After the welding of the bottom plates is completed, the installation of the wall plates begins. After two rows of wall plates are installed, U-Profile support rings are placed.

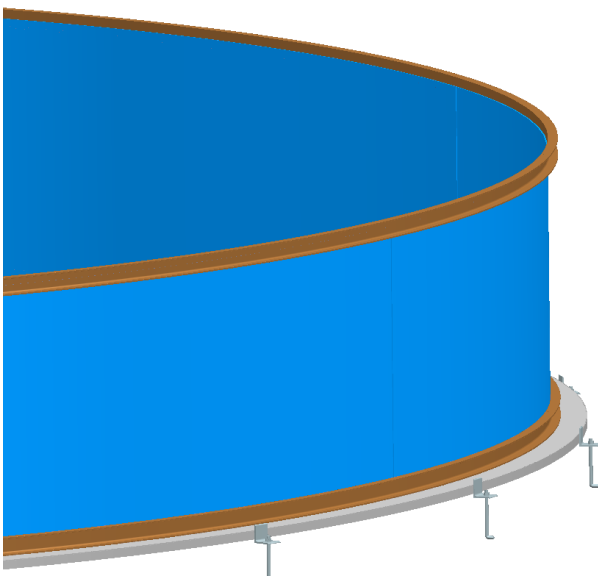
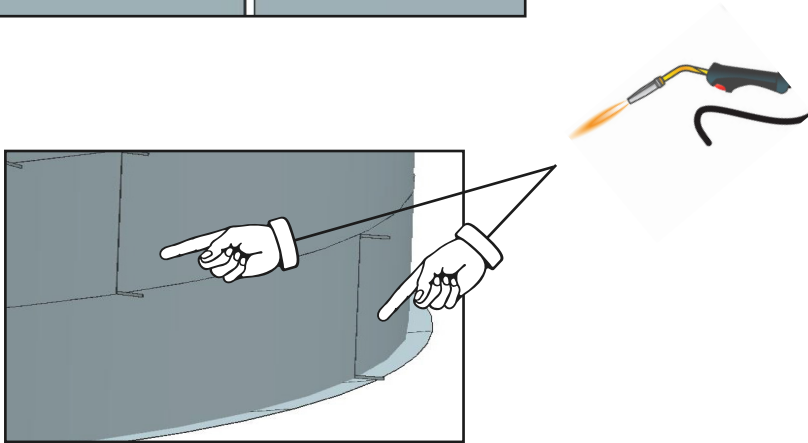
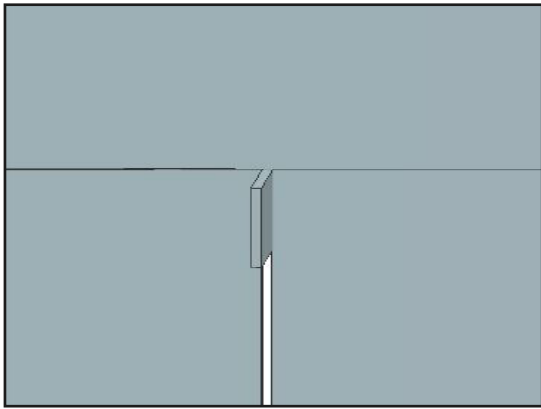

STRUCTURE



HEATING



CO₂



VENTILATION & COOLING



HIGH PRESSURE FOGGING



AIR HANDLING UNIT (AHU)



IRRIGATION



ELECTRICITY & AUTOMATION



Before starting the installation of the 4th layer, the installation of the components that will hold the insulation and trapezoidal sheet begins

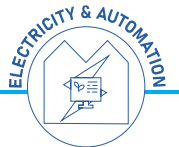
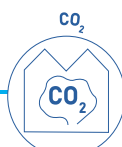
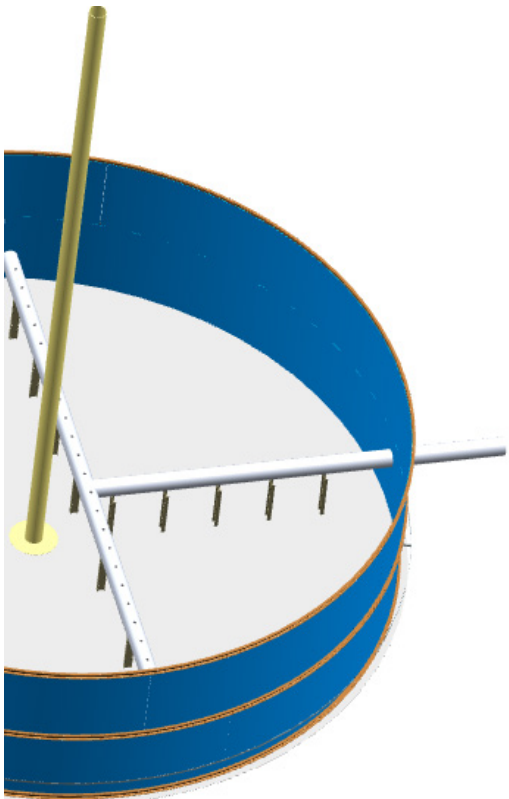
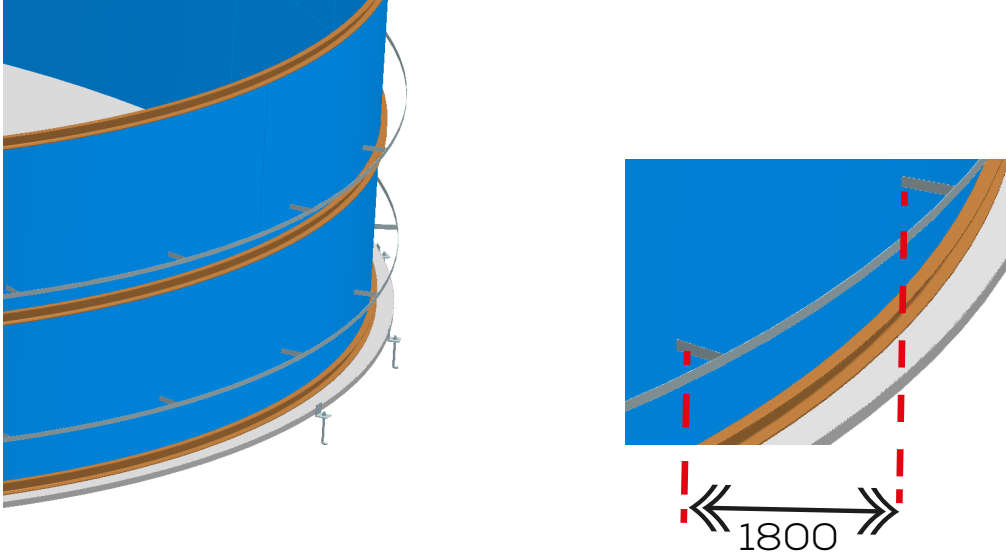

Before starting the installation of the 4th layer, a 6-meter section of the central column is installed and supported to prevent tipping. Then, the supports of the distribution pipe are placed.

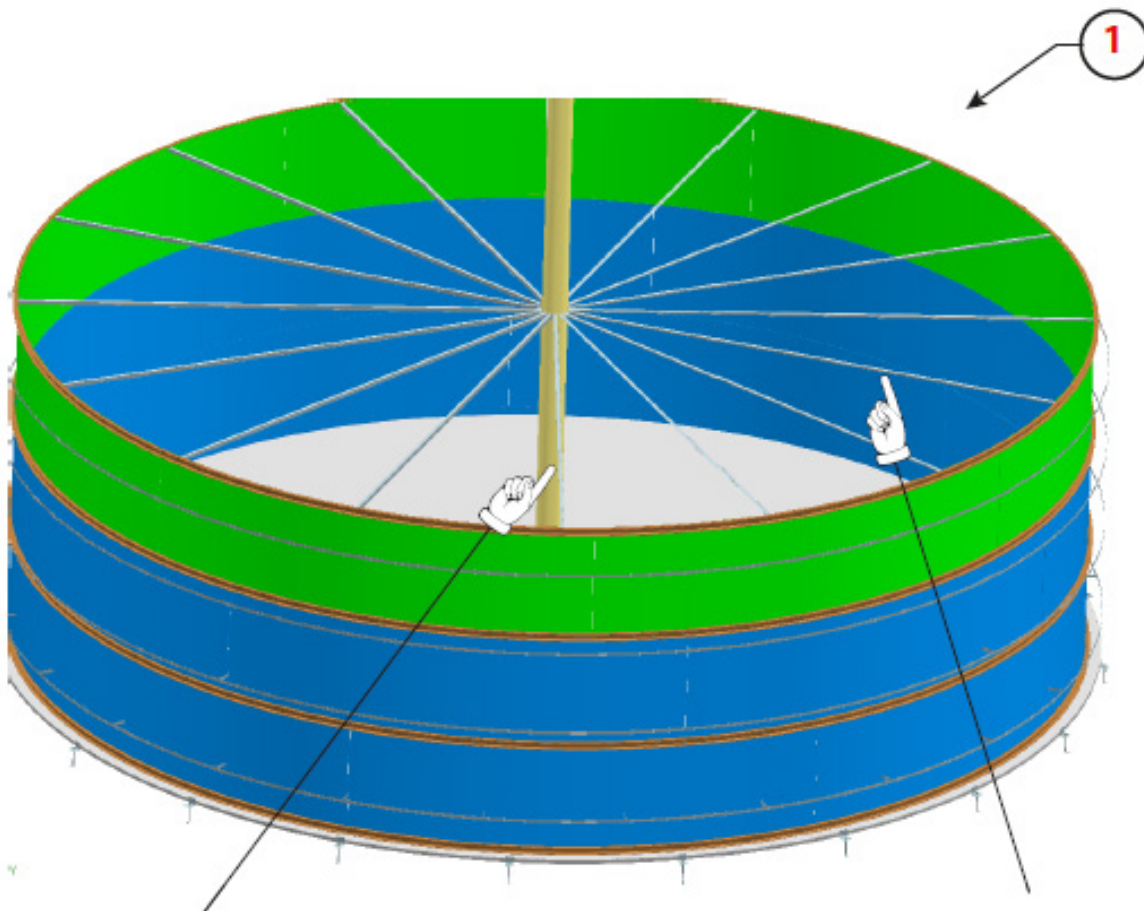

P1
50 × 50 L Profile
16 pieces

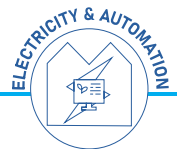
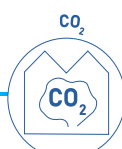

The distribution pipe, drain pipe, distribution pipe wall support, walkway, and tension bars are installed. Afterwards, the remaining wall and wall-mounted equipment installation is completed. The drain, transfer pipe, and internal ladder assemblies are completed. Finally, the roof ring, which will hold the roof profiles, is installed.

1250 TONS

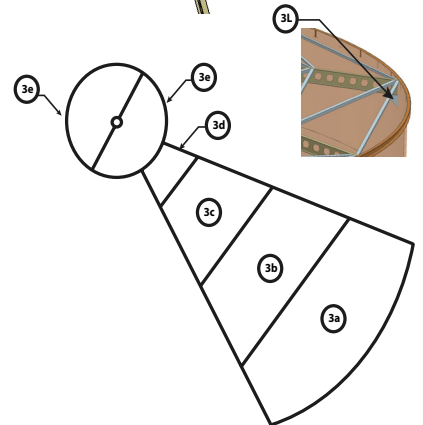
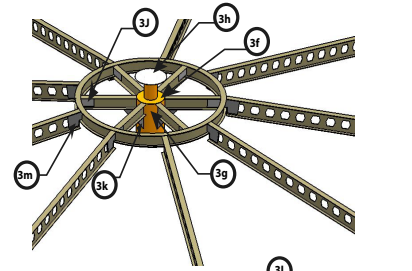
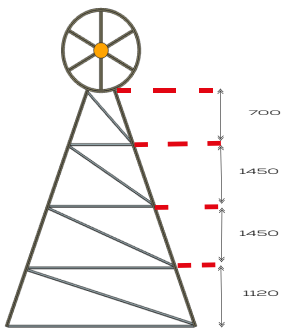
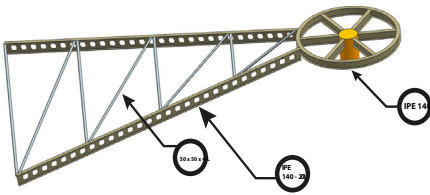

1250 TONS

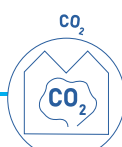
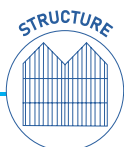
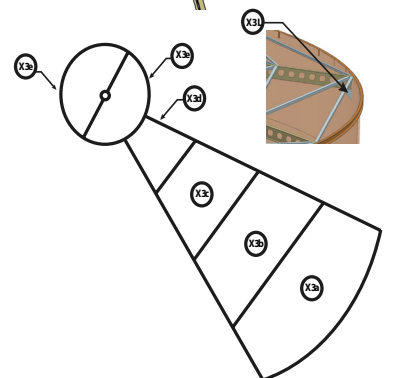
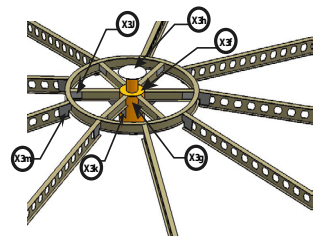
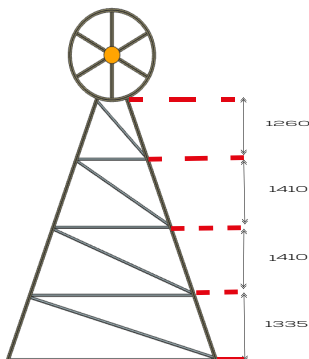
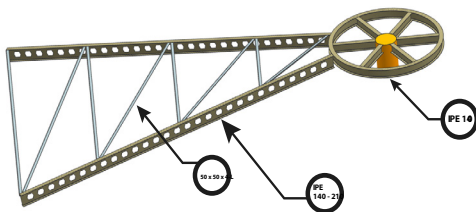

2500 TONS

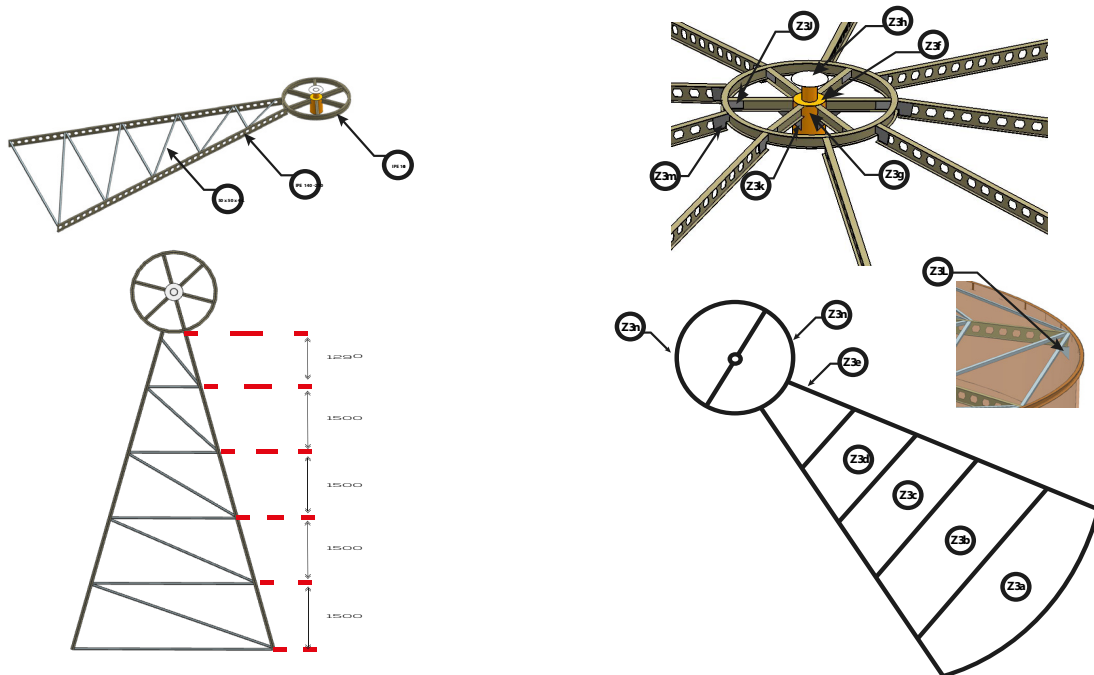

The main supporting sections of the roof support profiles shown in the illustration are assembled.

The upper distribution pipe is installed.

The installation of the remaining roof profiles is completed.

After assembling the distribution pipe, the remaining roof profiles are positioned.

The external ladder is assembled.

The roof plates are installed.

The walkway, safety valve pipe, and nitrogen pipe are assembled.

The trapezoidal sheet support profiles on the roof are installed.

After the tank assembly is completed, welding inspections are carried out.

After the welding inspection, the tank is filled with water and a leak test is performed.

Once the leak test is completed, the tank is drained, and anti-corrosion painting is applied.

After painting, the insulation and trapezoidal sheet installation are performed, completing the tank assembly.

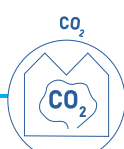
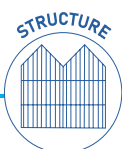

4.2 Technical Details

Steel profiles in accordance with international standards – NPU, IPE, Box profile, L profile

High-quality insulation materials – Rock wool, Antipas paint

Safety maintenance equipment – Roof guardrail, ladder guardrail, internal ladder, manholes, drain pipes

Operational safety – Sensor locations, Safety valve, AZOT system

Water Capacity: 500 tons – 3000 tons

Empty Weight: 23 tons – 72 tons

Safety Valve: Between DN80 and DN200

Water Inlet and Outlet: DN300

Drain Pipe: DN150

Overflow Pipe: DN100

AZOT Connection: DN15

Manhole: Ø800

Plate Thicknesses:

Roof: 3 mm

Walls: 4–8 mm

Bottom: 6 mm

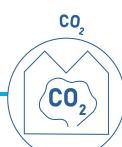
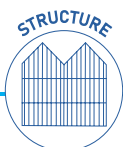
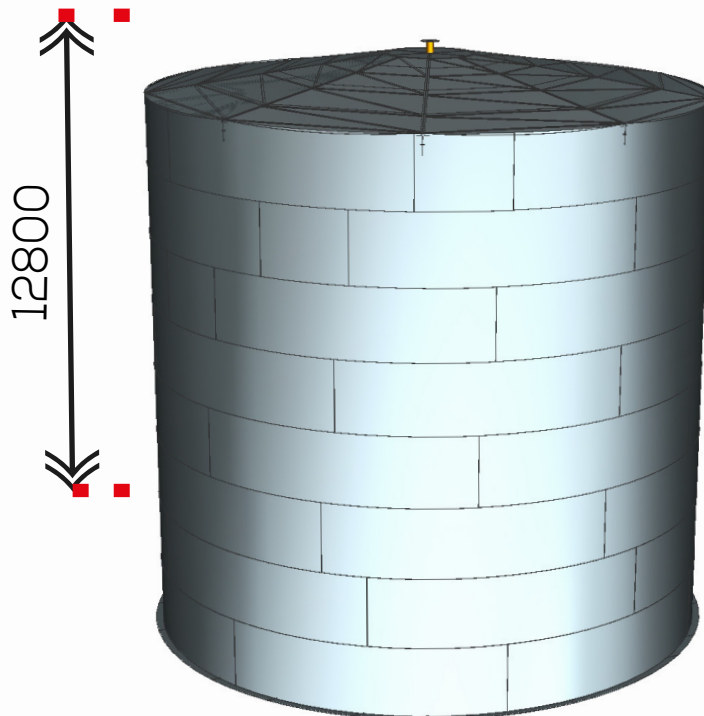

Safety Valve:

PRESSCON PV 200/25/20-2, PV 150/25/20-2, PV 80/25/20-2

Metal Parts: 304 Grade Stainless Steel

Seal: Rubber

Connection Type: Flanged connection

Opening Pressure: 25 mbar (o) relative (1.025 bar absolute)

Operating Pressure Opening: 20 mbar (o) relative (1.020 bar absolute)

Vacuum Opening Pressure: -2 to -4 mbar (o) absolute (0.998 - 0.996 bar absolute)

Maximum Temperature: 120°C

Each vacuum pressure relief and vacuum protection valve manufactured by PRESSCON VALVES BV is calibrated and tested in accordance with applicable standards and regulations.

Maintenance Procedure for Vacuum Pressure Relief Valves

- Annual inspection of vacuum pressure relief valves
- Annual testing to ensure that the vacuum pressure relief valve is operating satisfactorily

Follow the maintenance instructions below:

- 1.Check the manometer on the AZOT generator.
- 2.Then climb up to the buffer tank and check the air flow of the safety valve. The safety valve must operate within the specified range. When the specified value is reached, the vacuum or venting cap will operate.
- 3.Protective covers may become deformed or compressed. Remove them from the indicated points in the diagram and check the internal positions.
- 4.Ensure that the silicone rings are not deformed.

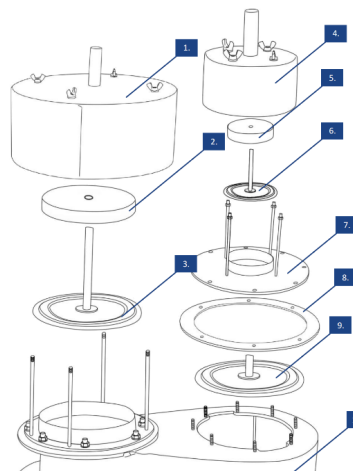
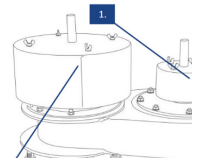
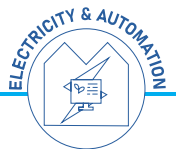
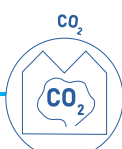

Diagram Components

- 1.Pressure relief cap
- 2.Weight
- 3.Valve
- 4.Operating pressure cap
- 5.Operating pressure weight
- 6.Operating pressure valve
- 7.Cap plate
- 8.Silicone gasket
- 9.Vacuum valve
- 10.Safety valve body



5. Maintenance Instructions

During maintenance and repair work, the tank must not be touched or used. Attach a sign on the tank and on the connected line valves reading “Under Maintenance – Do Not Touch” or “Under Repair – Do Not Touch.”

Maintenance and repair work must only be carried out by trained and authorized personnel. Service operations must always be performed by an authorized service provider.

Before any maintenance or repair, the system must be shut down and the electrical power to the system must be cut off.

Valves connected to the tank must be secured.

If certain parts need to be removed during repair, appropriate safety precautions must be taken.

After maintenance and repair work, the system operator must check the safety status of the system and verify that all safety equipment is operational.

All equipment on the tank must be serviced periodically in accordance with the manufacturer’s operation and maintenance instructions.

Before working inside the tank, it must be drained according to these instructions.

Before entering the tank, ensure that the AZOT generator is deactivated and that a “Under Maintenance – Do Not Touch” sign is displayed.

The tank should be entered only after it has been properly ventilated.

In case of any emergency, immediately exit the tank!

Before draining the tank, the top manhole cover must be opened.

During draining, the drain valve should be opened gradually.

Before refilling, ensure that the drain valve is closed and the overflow valve is open.

Before refilling, also ensure that the top manhole cover is open.

After all maintenance operations are completed, allow AZOT flow into the tank.

The tank’s internal pressure should be checked periodically on the AZOT line manometer, within a range of 0–100 mBar.

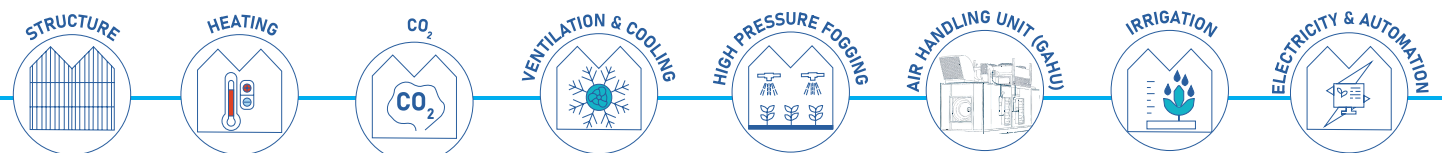

**Çerkeşli Osb Mah. İmes 7.Cadde
No:3 Dilovası/Kocaeli**

+90 262 244 44 94